

## Unit 1: Multimedia

Notes

### CONTENTS

Objectives

Introduction

- 1.1 Meaning and its Usage
  - 1.1.1 Categories of Multimedia
  - 1.1.2 Features of Multimedia
  - 1.1.3 Applications of Multimedia
- 1.2 Stages of Multimedia Project
  - 1.2.1 Pre-Production
  - 1.2.2 Production
  - 1.2.3 Post-production
- 1.3 Multimedia Skills Required in a Team
- 1.4 Summary
- 1.5 Keywords
- 1.6 Review Questions
- 1.7 Further Readings

### Objectives

After studying this unit, you will be able to:

- Describe the meaning of multimedia system and its usage.
- Understand the stages of multimedia projects.
- Explain multimedia skills required in a team.

### Introduction

Multimedia is something people can see, hear, touch and read on websites, radio, television, video games, phone applications, retail stores, cinema halls and ATMs. Multimedia can be defined as a combination of picture, text, sound, video and animation. In simple terms, multimedia is the combination of more than one media.

Multimedia is the medium which provides information to the users in the form of text, audio, video, animation and graphics. The information is delivered to the users by digital or electronic means. When a user is allowed to control the elements of multimedia then it becomes interactive multimedia. Interactive multimedia is called hypermedia when the user is given the structure of linked elements to control it.

## 1.1 Meaning and its Usage

Multimedia is a mixture of different forms of media. This includes text, graphics, audio, video, etc. Today, multimedia is found everywhere in educational institutes, offices, airports, railway stations, journalism, creative and entertainment industries such as TV, films, radio, etc., medicine, IT industry, research, etc. The kinds of media components and how they are used in a multimedia program matter a lot.



*Example:* A music video and sound should be used together as one without another would lose its significance.

Multimedia provides important information in an interactive way with the usage of images, graphics, animation, video and audios. For this reason, it is gaining popularity as a powerful educational tool. There are various multimedia software that are used in the field of education. CDs and DVDs are used to store information in different multimedia formats.



*Example:* A Powerpoint presentation involving text and graphics is a multimedia presentation.



Notes

### **Combining Content from Various Media**

There are various components that make up a multimedia production. In a program, more than one media element is necessary to call it a multimedia. Some examples of media are given below:

- Text and typography.
- Coloured, pictorial or graphical backgrounds
- Images and graphics such as photographs, illustrations, cartoons, diagrams, shapes, arrows, lines, etc.
- 2D and 3D animation.
- Audio files such as a song, sound effects, music, etc.
- Video files such as a short movie clip, advertisement, etc.
- Buttons and menu for easy navigation in a program.

### **1.1.1 Categories of Multimedia**

Based on how multimedia programs are used, multimedia can be divided into two forms – linear multimedia and non-linear multimedia. In linear multimedia, information is read or viewed in a continuous sequence. Usually, these presentations begin at a predetermined starting point and end at a predetermined end point. They can be automated so that each screen comes after a fixed time interval.



*Example:* Powerpoint presentation is one of the most common examples of linear multimedia.

On the other hand, non-linear multimedia information is not presented in sequential or chronological manner. Non-linear multimedia programs are usually interactive and require audience interaction.



Example: One of the most common examples of this form of multimedia is the Web.

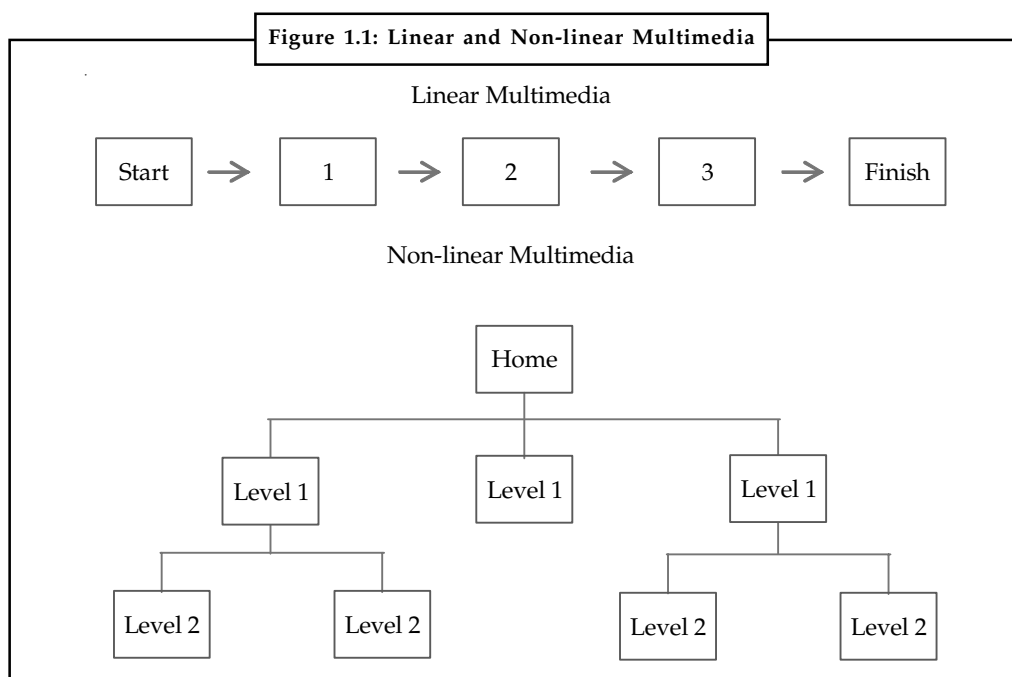

### 1.1.2 Features of Multimedia

Digital and computer based images, text, graphics, animation, audio and video that can be turned from one form to another are two fundamental features of multimedia. Generally, multimedia presentations are viewed in person in a boardroom, class, on stage or in an auditorium. They can be transmitted, projected or played on a projector using a media player such as a computer. A live or recorded presentation is called a broadcast.

Multimedia games can be used in a physical environment with multiple users in an online network, with special effects or with an off-line computer or game system. Interaction in a multimedia program can be increased by mixing multiple forms of media content. However, depending upon the kinds multimedia content available, it may differ online.



*Did u know?* Global positioning system (GPS) is popular multimedia device used for mapping routes and directions while driving, travelling or hiking.

Multimedia is progressively becoming data-driven and object-oriented which allows applications with cooperative end-user innovation and personalization on many forms of content over a period. For instance, content available on various websites such as photo galleries that have both content and images user-updated, to simulations whose events, animations, illustrations or videos are changeable, enabling the multimedia experience to be changed without reprogramming.

### 1.1.3 Applications of Multimedia

Multimedia can be used in a variety of ways in myriad fields. A multimedia presentation can be put together in varied formats. Some of the most common applications are given below:

Notes

Figure 1.2: Individual Multimedia Elements

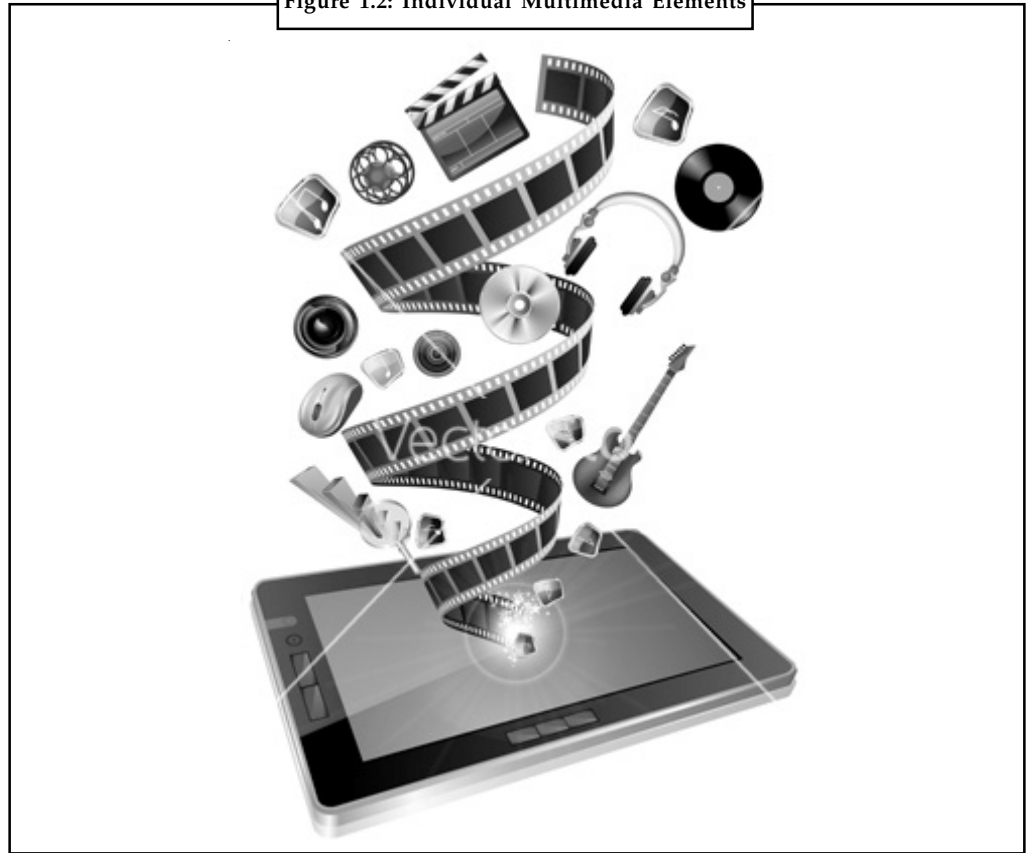

Source: <http://www.vectorstock.com/i/composite/33,45/tablet-multimedia-vector-743345.jpg>

**Business**

Multimedia is used for advertising and selling products on the Internet. Some businesses use multimedia tools such as CD-ROMs, DVDs or online tutorials for training or educating staff members about things the employer want them to learn or know. Staff members can learn at their own speed and at a specific time suitable to them as well as the company. It also saves money of the employers as now they don't have to pay extra expenses on training or education of their human resources. Multimedia is one of the best ways to provide short-term training to the workers in a company.



*Caution* Make your multimedia to the point and precise or it can have adverse effects on the business in financial terms.

**Research and Medicine**

Multimedia is increasingly used in research in the fields of science, medicine and mathematics. It is mostly used for modelling and simulation. For instance, a scientist can look at a molecular model of a particular substance and work on it to arrive at a new substance. In Medicine, doctors acquire training by watching a virtual surgery or they can simulate how the human body is affected by diseases spread by germs and then develop techniques to prevent it.

## Public Access

## Notes

Public Access is an area of application where several multimedia applications will be available very soon. One of the application is the tourist information system, where a travel enthusiast will be shown glimpse of the place he would like to visit. With the help of multimedia various source providing applications could be created.

## Entertainment

Multimedia is used to create special effects in films, TV serials, radio shows, games and animations. Multimedia games are popular software programs that available online as well as on DVDs and CD-ROMs. Use of special technologies such as virtual reality turn these games into real life experiences. These games allow uses to fly aeroplanes, drive cars, do wrestling, etc.



*Example:* Flight simulator is an example that creates a real life imaging.



*Did u know?* IBM released the first portable computer with fixed monitor with keyboard and data storage in 1975.

## Industry

In the Industrial sector, multimedia is used to present information to all people related to the industry such as stakeholders, shareholders, senior level managers and co-workers. Multimedia is also helpful in advertising and selling products all over the world over internet.

## Commercial

Creative presentations are used to grab the attention of the masses in advertising. Industrial, business to business and interoffice communications are mostly developed by firms providing creative services. They work on advanced multimedia presentations rather than simple slide shows to sell ideas or make training programs more interesting.

## Education

Multimedia is used as a source of information in the field of education. Pupils can research on various topics such as solar system or information technology using different multimedia presentations. To make teaching more interesting and fun for pupils, teachers can make multimedia presentations of chapters. Visual images, animation, diagrams, etc., have more effect on pupils. Various computer-based training (CBT) courses are also available online for study.

## Multimedia in Public Places

In railway stations, hotels, museums, grocery stores and shopping malls multimedia will become available at stand-alone terminals to provide information and help. Such installation reduce demand on traditional information booths and personnel, add value, and they can work around the clock, even in the middle of the night, when live help is off-duty.

Notes

**Engineering**

Software engineers may use multimedia in computer simulations for anything from entertainment to training such as military or industrial training. Multimedia for software interfaces are often done as collaboration between creative professionals and software engineers.

**1.2 Stages of Multimedia Project**

A multimedia program should go through various multimedia production phases. There are three main stages of a multimedia project:

1. **Pre-production:** The process before producing multimedia project.
2. **Production:** The process in which multimedia project is produced.
3. **Post-production:** The process after the production of multimedia project.

These stages are sequential. Before beginning any work, everybody involved in the project should agree to what is to be done and why. Lack of agreement can create misunderstandings which can have grim effects in the production process. Therefore, initial agreements give a reference point for subsequent decisions and assessments. After the clarification of why, what multimedia product has to do in order to fulfil its purpose is decided. The “why” and “what” determine all the how decisions including storyboards, flow chart, media content, etc.

**1.2.1 Pre-Production**

**Idea or Motivation**

During the initial why phase of production, the first question the production team ask is “why” you want to develop a multimedia project?

- Is the idea marketable and profitable?
- Is multimedia the best option, or would a print product being more effective?

**Product Concept and Project Goals**

It takes several brainstorming sessions to come up with an idea. Then the production team decides what the product needs to accomplish in the market. It should keep in account what information and function they need to provide to meet desired goals. Activities such as developing a planning document, interviewing the client and building specifications for production help in doing so.

**Target Audience**

The production team thinks about target age groups, and how it affects the nature of the product. It is imperative to consider the background of target customers and the types of references that will be fully understood. It is also important to think about any special interest groups to which the project might be targeted towards, and the sort of information those groups might find important.

**Delivery Medium and Authoring Tools**

The production team decides the medium through which the information reach the audience. The information medium can be determined on the basis of what types of equipment the audience

have and what obstacles must be overcome. Web, DVDs and CD-ROMs are some of the common delivery mediums. The production team also ascertain what authoring tools should be used in the project. A few of the authoring tools are graphics, audio, video, text, animation, etc.



*Task* Buy two game or educational CDs, study them and list their features.

## Planning

Planning is the key to the success of most business endeavours, and this is definitely true in multimedia. This is because a lack of planning in the early processes of multimedia can cost later.

The production team works together and plan how the project will appear and how far it will be successful in delivering the desired information. There is a saying, "If you fail to plan, you are planning to fail."

Group discussions take place for strategic planning and often the common points of discussions are given below:

- What do you require for the multimedia project?
- How long will each task take?
- Who is going to do the work?
- How much will the product cost?

Planning also includes creating and finalizing flowchart and resource organization in which the product's content is arranged into groups. It also includes timeline, content list, storyboard, finalizing the functional specifications and work assignments. Detailed timelines are created and major milestones are established for the difficult phases of the project. The work is then distributed among various roles such as designers, graphic artists, programmers, animators, audiographers, videographers, and permission specialists.

### 1.2.2 Production

In the production stage all components of planning come into effect. If pre-production was done properly, all individuals will carry out their assigned work according to the plan. During this phase graphic artists, instructional designers, animators, audiographers and videographers begin to create artwork, animation, scripts, video, audio and interface. The production phase runs easily if the project manager has distributed responsibilities to the right individuals and created practical and achievable production schedule. Given below are some of the things that people involved in production have to do:

#### Scriptwriting

The scripts for the text, transitions, audio narrations, voice-overs and video are written. Existing material also needs to be rewritten and reorganized for an electronic medium. Then the written material is edited for readability, grammar and consistency.

#### Art

Illustrations, graphics, buttons, and icons are created using the prototype screens as a guide. Existing photographs, illustrations, and graphics are digitized for use in an electronic medium.

**Notes**

Electronically generated art as well as digitized art must be prepped for use; number of colours, palettes, resolution, format, and size are addressed.

**3D Modelling and Animation**

The 3D artwork is created, rendered, and then prepared for use in the authoring tool. The 3D animations require their own storyboards and schedules.

**Authoring**

All the pieces come together in the authoring tool. Functionality is programmed, and 2D animation is developed. From here, the final working product is created. Every word on the screen is proofread and checked for consistency of formatting. In addition, the proofreader reviews all video and audio against the edited scripts.

**Shooting and Recording Digitizing Video**

The edited scripts are used to plan the budget, performers, time schedules and budget, then the shoot is scheduled followed by recording.

**Quality Control**

Quality control goes on throughout the process. The storyboards are helpful for checking the sequencing.

The final step checks should be done for the overall content functionality and usability of the product. The main goal of production is to make the next stage, post production, run smoothly and flawlessly.



*Notes* Production provides the raw components that will be blended together to create the final outcome of the multimedia project. If the components are flawed, the end product will also be flawed.

**1.2.3 Post-production**

After the production of the multimedia project, post-production technicalities should be addressed to produce a perfect and error free project. It is one of the most fundamental of all stages of production. The stage of post-production involves:

**Testing**

The product is tested on multiple computers and monitors. It is imperative to evaluate, test and revise the product to make sure the quality and success of the product.

**Mastering**

Mastering can be as simple as writing a CD-ROM or floppy disk. Or it can be as complex as sending the files to a service that will create a pre-master from which the master is made.



## Archiving and Duplication

Notes

The original files, including audio, video, and the native software formats, are archived for future upgrades or revisions. The duplicates are created from the original and packaged accordingly.

## Marketing and Distribution

Marketing is significant to the success of a product. The survival of a company and its products depends greatly on the product reaching the maximum number of audience. Then comes the final step in the process which is distribution of the multimedia project.



*Task* Prepare your own multimedia project on any topic of your choice.

## Self Assessment

Choose the correct option to answer the following:

- Multimedia is the integration of multiple forms of .....
  - Devices
  - Media
  - Technologies
  - All of the above
- What is the term for presentation that are sequential and typically do not have interactivity?
  - Linear
  - Non-linear
  - Hyperlinked
  - None of the above
- Which of the following is not considered digital?
  - Scanned pictures
  - Audio cassette tapes
  - Web interface buttons
  - Computer animations
- A live or recorded presentation is called a .....
  - Powerpoint presentation
  - Announcement
  - Multimedia presentation
  - Broadcast
- What is the other name for interactive multimedia?
  - Hypertext
  - Graphic media
  - Hypermedia
  - Print media

### 1.3 Multimedia Skills Required in a Team

All through the creation and development of a multimedia project, the team members must communicate with each other on a constant basis. They must also share same goals and consistency in the design of the end product.

Depending upon the size of a project, one specialist might be required to play more than one role, or the roles might be extended to different departments. Every specialist team member is not only required to have an extensive background in their fields but also be a fast learner capable of picking up new skills. Knowledge and experience in other fields might be an added

**Notes**

advantage. Every team member plays a significant role in the design, development and production of a multimedia project.

A multimedia team members consists of the following:

- Project manager
- Multimedia designer
- Interface designer
- Multimedia programmer
- Computer programmers
- Writer
- Subject matter expert
- Audio specialist
- Video specialist
- Producer for the Web
- Permission specialist

**Skills Required for Various Team Members**

The project manager is responsible for:

- The overall development, implementation, and day-to-day operations of the project.
- The design and management of a project.
- Understanding the strengths and limitations of hardware and software.
- Make schedules.
- Decide the budget of the project.
- Interact with team and clients.
- Provides resolution to development and production problems.
- Motivate people and should be detail oriented.

*Multimedia designer* – This team consists of graphics designers, illustrators, animators, and image processing specialists, who deal with visuals, thereby making the project appealing and aesthetic. This team is responsible for:

- Instructional designers, who make sure that the subject matter is presented clearly for the target audience.
- Interface designers, who devise the navigational pathways and content maps.
- Information designers, who structure content, determine user pathways and feedback, and select presentation media.

An interface designer is responsible for:

- Creating a software device that organizes content. It allows users to access or modify content, and presents that content on the screen.
- Building a user-friendly interface.

A multimedia writer is responsible for:

Notes

- Creating characters, actions, point of view, and interactivity.
- Writing proposals and test screens.
- Scripting voice-overs and actors' narrations.

A video specialist needs to understand:

- The delivery of video files on CD, DVD, or the Web.
- How to shoot quality video.
- How to transfer the video footage to a computer.
- How to edit the footage down to a final product using digital non-linear editing system (NLE).

An audio specialist is responsible for:

- Locating and selecting suitable music talent.
- Scheduling recording sessions.
- Digitizing and editing recorded material into computer files.

A multimedia programmer is responsible for:

- Locating audio/video resources.
- Selecting suitable audio/video clips.
- Creating audio/video clips.
- Interacting with project managers and instructional designers.
- Participating in the design process.
- Working on storyboard and uses it as a guideline.
- Finding out problems, solving them and fixing bugs.
- Writing understandable, easy and reusable codes
- Liaising with designers
- Integrates all the multimedia elements into a seamless project, using authoring systems or programming language.
- Manages timings, transitions and record keeping.

## Self Assessment

Choose the correct option to answer the following:

6. .... software is used with scanner and can scan text into computer's memory as a word-processed document.
  - (a) Optical Character Recognition
  - (b) Character Recognition
  - (c) Digital Text Recording
  - (d) Graphic Tablet
7. Which of the followings is not the function of a project manager?
  - (a) The design and management of a project.

Notes

- (b) Building a user-friendly interface.
  - (c) Provides resolution to development and production problems.
  - (d) Decides budget of the project.
8. Which of the following is the last stage of production?
- (a) Testing
  - (b) Marketing
  - (c) Distribution
  - (d) Conceptualising
9. In multimedia, what does NLE stand for?
- (a) Non-linear editing system
  - (b) New Linear Edit
  - (c) Non-graphic Licence e code
  - (d) None of the above
10. Which of the following is not a multimedia team member?
- (a) Computer programmers
  - (b) Subject matter expert
  - (c) Producer
  - (d) Permission specialist



Case Study

**Future of Multimedia**

There seems to be a rising flourish of enthusiasm about Internet courseware and multimedia. Additional individuals learn, the more they want to learn. For example, once their essential classes Web pages are complete, instructors often decide that they want pictures, then perhaps some audio, then animation, then.

There are a number of advantages to using audio over the Internet. Professors are able to create archived lectures or live broadcasts, allowing for asynchronous or synchronous communication. They have been experimenting with live audio broadcasts, and they see an advantage in the interaction: students can call in (similar to a talk radio show) and talk to the professor, rather than passively listening. Audio over the Internet also allows instructors to provide guest lecturers from all over the world at low cost. The capacity to archive these presentations makes them available at times convenient for students for review, or for the first time if they miss a live presentation.

The current advantages and disadvantages of multimedia online are multimedia allows people to communicate more effectively online. I believe that with technology like 3-D modelling and virtual reality, people from different places will be able to work in groups to construct projects over the Internet. I also see multimedia as a shape of self-expression: it enables the creator to add personality to a website or course. Multimedia, whether in the form of video, animation or a scanned picture can demonstrate concepts or ideas that cannot be communicated easily in any other way.

The future of multimedia online is at present, video is rather primitive, but in the future users will be able to interact visually with people from all over the world. I don't see multimedia replacing human contact; rather, it will supplement it by allowing individuals to interact in ways and places that would otherwise be impossible.

According to Allyn J Radford, Senior Research Fellow in the Faculty of Art, Design and Communication at RMIT University in Melbourne, Australia, "The future of interactive media in education, when it is separated from the issues of technology that tend to mystify

*Contd....*

## Notes

discussion and place it firmly in the sole grasp of those that are highly technologically capable, is that of communication tool. Its dimensions and capabilities will evolve and expand at the same time as the potential to author becomes more widely accessible. The potential for students of all ages to author as part of a creative educational program that is based on achievement of goals and competencies rather than time served will assist educators to shift from teacher to facilitator and mentor. Interactive communication tools will transform our capability to embrace an educational paradigm that deals with learning as a vital, fulfilling, and continuing part of life at home and in the workplace as well as within educational institutions."

**Questions:**

1. How is multimedia useful in daily life?
2. Can you imagine a life without multimedia? Explain.

Source: <http://www.studymode.com/essays/Future-Multimedia-60463.html>

**1.4 Summary**

- Multimedia is a combination of text, graphic art, sound, animation, and video.
- There are two types of multimedia projects – linear and non-linear.
- Multimedia projects are often stored on CD-ROM or DVDs and on the Web.
- Multimedia is widely used in business, schools, public places, hospitals, research, for entertainment, at home, etc.
- Virtual reality is an extension of multimedia.
- There are three stages of multimedia – pre-production, production and post-production.
- The team involved in a creating a multimedia project should be knowledgeable , experienced and efficient.
- Every team member should perform their responsibilities as well as others if need arises.

**1.5 Keywords**

**CD-ROM:** A subset of CD standards (ROM stands for "read only memory"); holds about 600 MB of data.

**Flow chart:** A graphical representation of a computer program arranged in sequence

**Non-linear Editing:** A multimedia project can be cut, altered and arranged in any order.

**Proofread:** One of the areas of editing in which every word is checked for grammar, spelling, punctuation, consistency of formatting, etc.

**Storyboard:** Drawings in a sequence with directions and dialogues already planned for a short film, etc.

**1.6 Review Questions**

1. What is multimedia? Describe.
2. What are different types of multimedia?
3. Explain the process and importance of planning in the production of multimedia project.

**Notes**

4. Write down the applications of multimedia.
5. What is multimedia on a computer system?
6. Explain in detail various steps involved in the process of production.
7. What is a multimedia designer? Explain in brief.
8. Why is team spirit essential for people working in a team?
9. What is the first stage of a multimedia project?
10. Multimedia has become an important entity in today's world. Explain.

**Answers: Self Assessment**

- |        |         |
|--------|---------|
| 1. (b) | 2. (a)  |
| 3. (c) | 4. (d)  |
| 5. (c) | 6. (a)  |
| 7. (b) | 8. (c)  |
| 9. (a) | 10. (c) |

**1.7 Further Readings**



*Books*

Frederick P. Brooks, Jr., Kenan Professor of Computer Science. *The Mythical Man-Month: Essays in Software Engineering*. University of North Carolina at Chapel Hill.

K. Andleigh and K. Thakkar. *Multimedia System Design*. PHI, PTR.

Steve Rimmer (2000). *Advanced Multimedia Programming*. MHI.

Tay Vaughan. *Multimedia Making it work*. Seventh Edition. Tata McGraw-Hill Education Private Ltd.



*Online links*

<http://nora.lis.uiuc.edu:3030/companion/view?docId=blackwell/9781405103213/9781405103213.xml&doc.view=print&chunk.id=ss1-2-10&toc.depth=1&toc.id=0>

[http://users.mct.open.ac.uk/yr258/papers/Rogers\\_Scaife98.pdf](http://users.mct.open.ac.uk/yr258/papers/Rogers_Scaife98.pdf)

<http://www.icheg.org/icheg-game-history/timeline/>

<http://www.ict.griffith.edu.au/teaching/1611ICT/mm1alectures/111/Writing%20For%20Multimedia%20Great%20Moments%20In%20Multimedia%20History.htm>

## Unit 2: Text

Notes

### CONTENTS

Objectives

Introduction

2.1 Fonts and Faces

2.1.1 Installation of Fonts

2.1.2 Selecting Text Fonts

2.2 Using Text in Multimedia

2.2.1 Using Text Elements in a Multimedia Presentation

2.2.2 Use of Text in Webs

2.2.3 Text in Films such as Titles and Credits

2.2.4 Text in Subtitles in a Film or Documentary

2.2.5 Text in Advertisements

2.2.6 Significance of Text Based Advertising

2.3 Font Editing and Design Tools

2.3.1 ResEdit

2.3.2 Fontographer

2.3.3 Type-Designer

2.3.4 Font Monger

2.3.5 Cool 3D Text

2.3.6 Font Chameleon

2.3.7 Making Pretty Text

2.4 Hypermedia and Hypertext

2.4.1 Referential and Organisational Links

2.4.2 Nodes, Links and Navigation

2.4.3 Information Structures

2.4.4 Future Developments

2.5 Summary

2.6 Keywords

2.7 Review Questions

2.8 Further Readings

Notes

## Objectives

After studying this unit, you will be able to:

- Understand different fonts and faces
- Describe text in multimedia
- Explain font editing and design tools
- Enumerate hypermedia and hypertext

## Introduction

Text has become a part of our life. It consists of characters, punctuation symbols, etc. to convey a message. We read text in newspapers, magazines, pamphlets, billboards, books, websites, etc. It is also an integral part of songs, movies, TV, radio, advertisements, video games, presentations, etc. Text in multimedia is combined with various other kinds of media such as audio, video, graphics, pictures, animation, etc.

Text is one of the most imperative components of multimedia and an essential source of presenting information to a wide range of people. Proper use of text, keeping in mind elements such as font style, size and various design tools help the content creator to communicate the idea and message to the user. Text is also the most widely used and flexible means of communicating information and ideas on an electronic media.

Billboards are used in a public place where a large number of people can see it. To make sure everybody can see the billboard, a clear, large font style and size is used. It is also important to use text in concise manner so that the billboard does not look text heavy and can be easily and quickly read by people.

A multimedia developer can also customise fonts according to his wants and design. There are various software available in the market that help in creating a variety of typefaces. The involvement of text in hypermedia and hypertext on internet allows the users to read information, listen to music, play games, shop online. Hypertext use hyperlinks to present text and graphics whereas interactive multimedia is called hypermedia. In this unit, you will learn about linear and nonlinear media, nodes, links and navigation, information structure and design process.

## 2.1 Fonts and Faces

Text is one of the easiest of all multimedia elements to use. Most computer users are familiar with word processing and know the processes of entering and editing text and working with fonts and font sizes.

Factors affecting legibility of text are as follows:

- Size and style
- Background and foreground colours
- Leading

A glyph is a graphic representation of a character's shape where a character may be represented by many glyphs. A typeface is a family of many characters often with many type sizes and styles. On the other hand, a font is a collection of character or glyphs of a single size and style belonging to a particular typeface family.



Many fonts are also available online and people can download them from a server. They are classified on the basis of spacing between characters, words, presence or absence of serifs, their shape, stretch and weight such as bold or italics. Underlining, outlining and strikeout of characters may also be added in the text.

Figure 2.1: Different Types of Fonts



Source: [http://www.examiner.com/images/blog/EXID19783/images/type\\_safe-fonts\\_thumb.png](http://www.examiner.com/images/blog/EXID19783/images/type_safe-fonts_thumb.png)

Font size is measured in points and it does not describe the height or width of its character. This happens because the height of two different fonts (in both upper and lower case) may differ. One point is approximately 1/72 of an inch i.e., 0.0138.

Figure 2.2: Examples of Different Fonts and Font Sizes

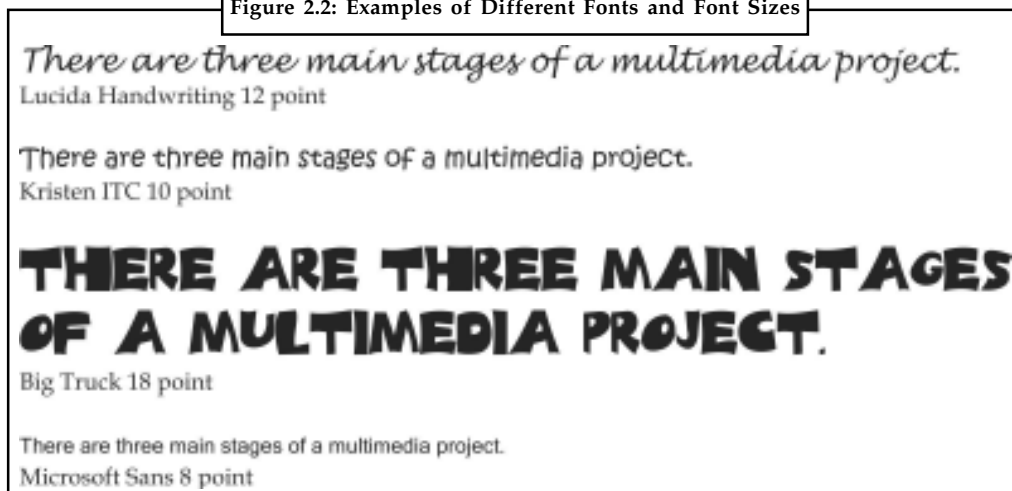

Fonts are very useful as they help in gaining attention of the reader by highlighting headings, increasing readability and project an image. They can be classified into three categories – serif, sans serif and decorative. The serif is the little decoration at the end of a letter stroke.



*Example:* Times New Roman, Bodoni, Bookman are some fonts which come under serif category. Arial, Avant Garde, Verdana are some examples of sans serif font.

Notes

Figure 2.3: Examples of Serif, Sans Serif and Decorative Fonts

Bodoni  
Interactive multimedia is called hypermedia.  
(This is a serif font. In this font, a line or curve extension from the end of a letter. Serif fonts are best used for body text.)

Avant Garde  
Interactive multimedia is called hypermedia.  
(This is a sans serif font. There are no extensions in this font. Sans Serif fonts are best used for titles.)

**Matura MT Script**  
**Interactive multimedia is called hypermedia.**  
(This is a decorative font. These fonts are stylish and formal and are best used for emphasis.)



*Did u know?* The spacing between character pairs is called kerning and the space between lines is called leading.

Text fonts are used for lengthy text passages, so they have to be simple and readable. Serif fonts are usually used for this purpose. On the other hand, display fonts are used for headlines and slogans. These fonts should be eye-catching and are not used for common purpose.



*Notes* Display font designed for multimedia may not look good on print whereas text fonts designed for print may not look good on a computer screen.

### 2.1.1 Installation of Fonts

Fonts can be installed on the computer by opening the fonts folder through Windows Explorer. Go to C:\WINDOWS or C:\WINNT\FONTS. When the folder opens, select the fonts you want to install from an alternate folder and copy and paste them into the fonts folder. The second option is to go to Start > Settings > Control Panel > Fonts, then go to File > Install New Font.



*Caution* If there are too many fonts on the computer, or an older operating system, the above mentioned methods would not work. A computer user have to get a program like Adobe Type Manager, and use it to add fonts to the system.

### Usage of Fonts

After the installation of the font, you have to change the font of the present text in any text editing program. A user can also use the installed font in HTML documents but the document can be viewed by only those users who have the same font installed on their computers. Always remember the name of the font and keep in mind that the name of the font is not the same as the file name of the .ttf file. If a user does not remember the font name then he can find it by going through the font list or by visiting the .ttf file.

## 2.1.2 Selecting Text Fonts

Notes

There are a few things that a user must keep in mind before selecting fonts for a multimedia presentation. Reading the guidelines given below will help a user in choosing appropriate fonts:

- Choose a font that is legible and easy to read.



*Example:* San serif fonts are easier to read than serif fonts.

- The different effects and colours of a font can be chosen to make the text look distinctive.
- Try to use few different colours within the same presentation.
- Try to use few typefaces within the same presentation. Play with the style and size to match up to the purpose and importance of the text. For instance, use large font size for headings.
- Drop caps and initial caps can be used to accent the words.
- Anti-aliased can be used to make a text look gentle and blended.
- To attract instant attention to the text, the words can be wrapped onto a sphere or bent like a wave.
- In case of text links (anchors) on web pages the messages can be highlighted.
- Meaningful words and phrases can be used for links and menu items.
- Overcrowding of text on a single page should be avoided.
- Do not use decorative passages for longer paragraphs.



*Did u know?* The concept of using many fonts in a single page is called ransom-note topography.

## 2.2 Using Text in Multimedia

The basic element of multimedia is the text. However, the text should be kept minimum to avoid overcrowding unless the application contains a lot of reference material. Less text can be read easily and quickly unlike longer text passages which can be time consuming and tiring. A lot of information in a multimedia presentation is not ideally the best way to transfer information to a wide range of audience. Combining other elements such as pictures, graphics, diagrams, etc., can help reduce the amount of text written to provide information.

From design point of view, text should fill less than half the screen. There are following ways in which a text can be used in multimedia:

- in text messaging
- in advertisements
- in a website
- in films such as titles and credits
- as subtitles in a film or documentary that provide a translation

## 2.2.1 Using Text Elements in a Multimedia Presentation

The text elements used in multimedia are given below:

### Menus for Navigation

- A user navigates through content using a menu.
- A simple menu consists of a text list of topics.

### Interactive Buttons

- A button is a clickable object that executes a command when activated.
- Users can create their own buttons from bitmaps and graphics.
- The design and labelling of the buttons should be treated as an industrial art project.

### Fields for Reading

- Reading a hard copy is easier and faster than reading from the computer screen.
- A document can be printed in one of two orientations - portrait or landscape.
- The taller-than-wide orientation used for printing documents is called portrait.
- The wider-than-tall orientation that is normal to monitors is called landscape.

### HTML Documents

- HTML stands for Hypertext Markup Language which is the standard document format used for Web pages.
- HTML documents are marked using tags.
- An advanced form of HTML is DHTML that stands for Dynamic Hypertext Markup Language. It uses Cascading Style Sheets (CSS).

Some of the commonly used tags are:

- The <B> tag for making text bold faced.
- The <OL> tag for creating an ordered list.
- The <IMG> tag for inserting images.

### Symbols and Icons

- Symbols are concentrated text in the form of stand-alone graphic constructs and are used to convey meaningful messages and human emotions are called emoticons.
- Icons are symbolic representations of objects and processes.

### Text Layout

While creating a multimedia presentation, the presenter should plan the text layout to let a reader read it with ease. One of the first things to be kept in mind is the length of the text. It should neither be too long nor too short. For a printed document, a line containing 13 to 17 words

is sufficient. A line having more than 17 words should be too long to fit on a screen and would be difficult to follow. On the other hand, a very short line would not look good on screen. Therefore, for better presentation a line of around 8 to 15 words should be used.

The next point of concern is the consistency of pages. The designer has to make sure that the pages should be of same size. Moreover, every page should be designed in an eye-catching way. (see Figure 2.4)

Figure 2.4: Example of Good and Poor Page Layout

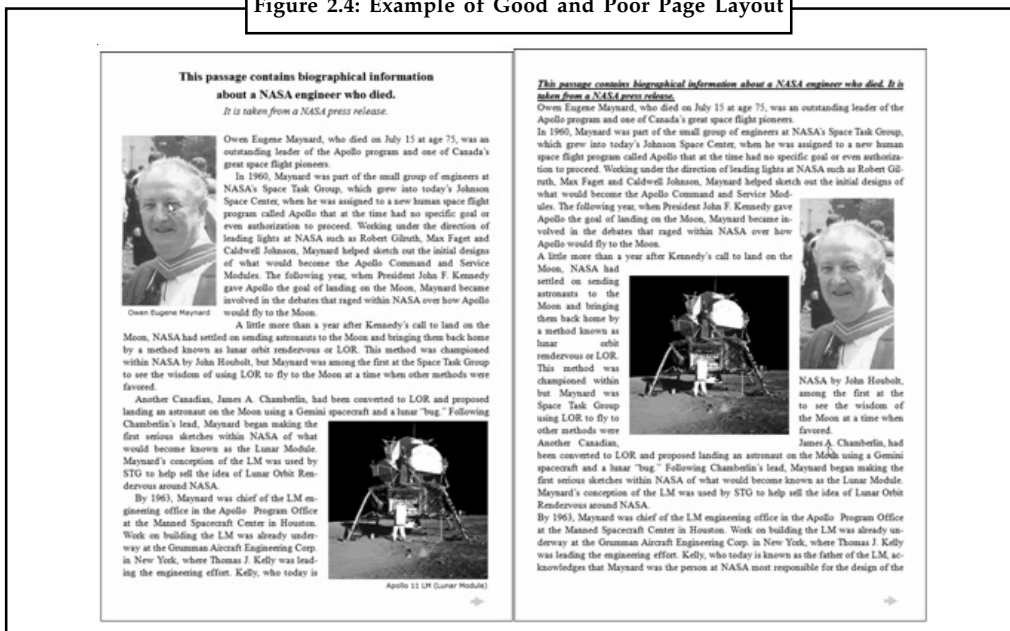

Source: [http://usabilitynews.org/wp-content/uploads/2012/09/pgset\\_1.gif](http://usabilitynews.org/wp-content/uploads/2012/09/pgset_1.gif)

The distance between two lines should be adjusted to a suitable value to increase readability. Ensure that the leading is not too small as then the text will be hard to read. (see Figure 2.5)

Figure 2.5: Effects of Different Leadings

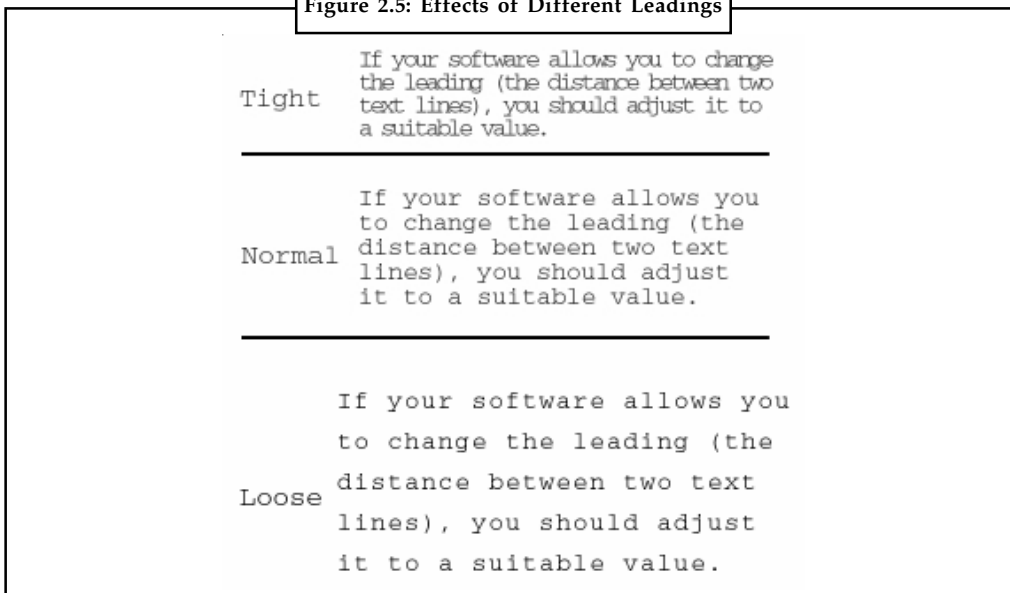

Source: <http://resources.edb.gov.hk/com-lit/it04/images/it04-u02/t02-im02-big.htm>

Notes

The other one of the most common errors people make is while choosing the background colour. Using a background colour too close to the text or a background image highly in contrast to the text which makes the text difficult to read. (see Figure 2.6)

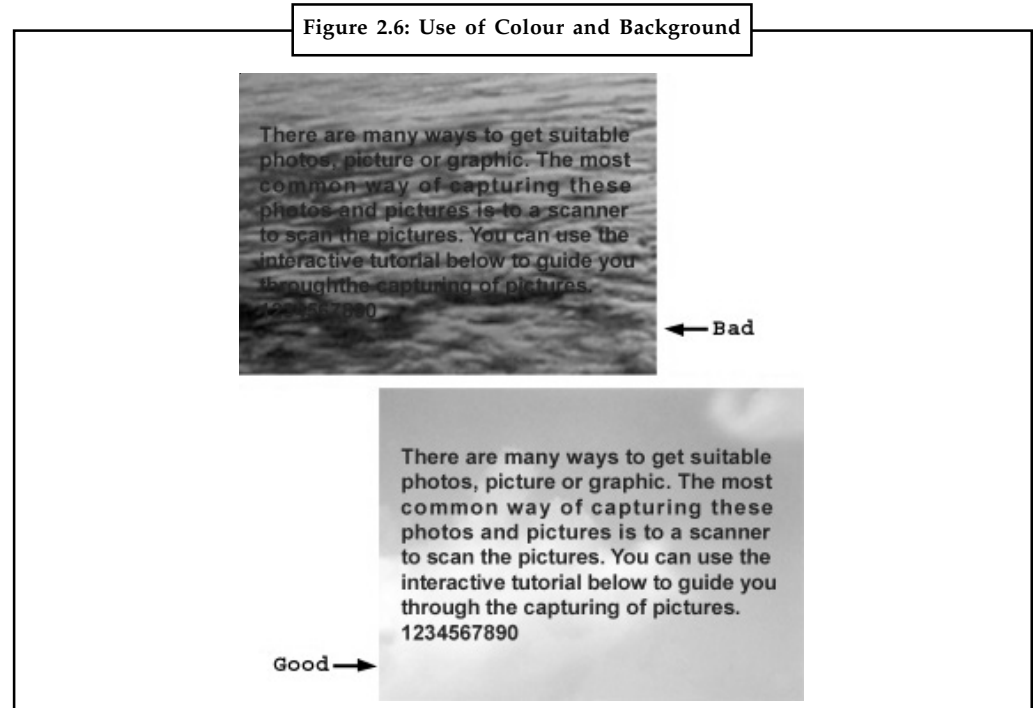

Source: <http://resources.edb.gov.hk/com-lit/it04/images/it04-u02/t02-im03-big.htm>

## 2.2.2 Use of Text in Webs

Using text in websites attract a visitor's attention as well as help him in understanding the webpage better. It is far better than the use of meaningless graphics and images which do not contribute in understanding of the page.

### Website Loading Speed

Website loading speed is one of the important factors that influences conversion as visitors starts to leave the page if it takes more than eight seconds to load. A website which contains a lot of text loads faster than the websites that contains the following:

- Internal code (not placed in external CSS, JS, etc. files and linked to)
- A lot of images and graphics
- JavaScript (for menus, including various stat tracking scripts, such as Google Analytics).
- Audio and video clips on the page (especially without transcripts, which hurts accessibility if you do use audio/video, do not auto-launch it and have a button to turn it on/off).
- Table-based layouts that are twice larger in file size, than the ones built in CSS.

Another important things is how easily visitors find what they are looking for which depends upon both eye catching images and informative text. However, informative text draws much more visitors than graphics and images. This is why text should be the primary concern of the website than graphic elements. Informative text can also boost search engine traffic and conversions to a great deal.

### 2.2.3 Text in Films such as Titles and Credits

Notes

Most films start with titles and end with credits. The text is shown over either plain background or coloured background. Typography look different in different formats such as a in film subtitles, on websites, poster, essay, etc. To include a text in multimedia, a designer has to keep in mind the points given below:

- the theme or look of the multimedia product.
- the amount of text needed.
- the placement of the text (heading, body text or logo).
- the format of the project (video, website, blog, video, slideshow, etc.,).
- the content of the information.

Figure 2.7: Use of Text in a Film Poster

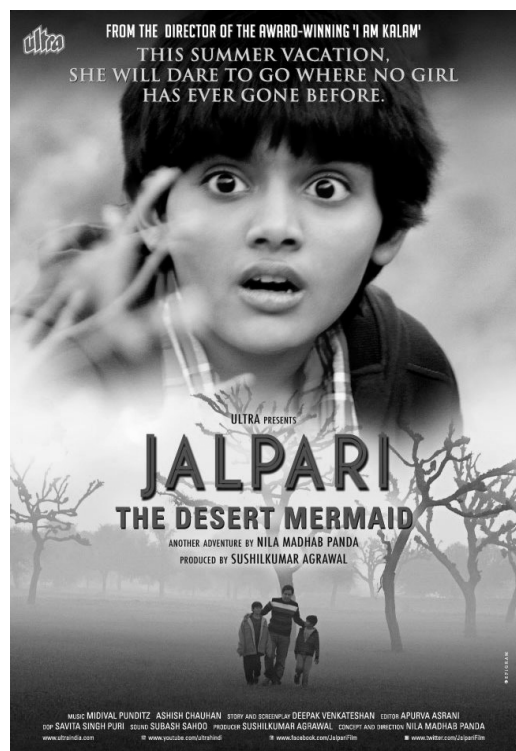

Source: [http://upload.wikimedia.org/wikipedia/en/3/3c/Jalpari\\_film\\_poster.jpg](http://upload.wikimedia.org/wikipedia/en/3/3c/Jalpari_film_poster.jpg)

### 2.2.4 Text in Subtitles in a Film or Documentary

Before adding subtitles to a film, people working on the film need to look into different font styles, spacing, font colour and size. Some fonts that work well on a website while some work well in print.



*Example:* Fonts such as Georgia, Verdana and Tahoma are great for use in a website as they are designed to work well in static design environments where the background does not change.

Notes

However, there are also some fonts that work well with moving images.



*Did u know?* Tiresias, Univers 45 and Antique Olive. These three fonts work well as subtitles over dynamic content and are great way of communicating with the audience.

While designing subtitles, a film maker will need to keep in mind that moving images interact with the top layer subtitles.



*Example:* If subtitles are white and rest on top of a similar white tone in the image, the text will be difficult and impossible to read. To ensure this does not happen, a black outline around text should be used. Now the text will be viewable even against common black and white backgrounds.

On the other hand, some filmmakers use a yellow font with black outline for their subtitles. Black outline increases the readability of the text. Film makers may also experiment with fonts for subtitles and can use Sans Sheriff fonts as they are much more readable than other fonts.

### 2.2.5 Text in Advertisements

The explosive growth of multimedia data on the web creates huge opportunities for further monetizing them with multimedia advertisements. Multimedia content becomes a natural information carrier for advertising in a way similar to radio wave to carry bits in digital communications. More and more business models are rolled out to freely distribute multimedia contents and recoup the revenue from the multimedia advertisements it carries. With the increasing importance of online multimedia advertising, researchers from multimedia community have made significant progresses along this direction.

Local business, such as a restaurant or bookstore, coffee shop, boutique or convenience store-owners use text advertising. Similarly, event planners and party organizers publicize their events by indulging in text advertising.

Some of the important features of advertising using text elements are as follows:

- The main headline may be the strongest element of the ad or it may be secondary to a strong visual. Some ads may have subheads and other title elements as well. Just making it larger isn't enough, headlines should be well-written to get the readers' attention.
- Try to choose a font that is easy to read. Buy a font or download a free font from the Internet that matches the style of your advertisement. Make sure the font is big enough to read. Design certain words to stand out from the text in order to create a lasting impression.
- Pick fonts that suit your business and conveys your message. Try using a creative and exciting font for a day care business, instead of a bold and serious font, such as times new roman.
- Stick with less than four different fonts in your design. Using too many fonts will create clutter in your advertisement. Try to avoid fancy fonts because they are hard to read. Never use all capital letters in a block of body text because the reader will not be able to read your message.
- Choose between a serif or a sans serif font when creating an advertisement. Use sans serif fonts for titles or headlines. Use serif fonts in large block of text because they are easier to read. Serifs are fonts that contain small lines at the ends of the letters, which makes them appear more detailed. Sans serif fonts are without serifs.



## Notes

- Make a decision on the right font size for your advertisement. Body copy in print ads tend to use an 11-point font size. Design headlines in a larger font size and allow for space between text blocks to create unity.
- Sentence structure is another key element. Sentences should be:
  - ❖ *short*: contained on one line.
  - ❖ *simple* containing one key idea;
  - ❖ no subordinate phrases or clauses;
  - ❖ no jargon or legalistic phrases.
- Large blocks of text are likely to deter a viewer from even attempting to read the contents. As a rule of thumb any text that takes up more than three full-length lines is likely to require higher than the minimum standards for both size and duration of hold.
- The text should be legible. Avoid using ornate, heavily serifed, italic typefaces as they offer poor readability. The visible space between words should be greater than the visible space between letters and the visible space between lines should be greater than the visible space between words. For this reason fully justified and proportional text should not be used.
- Avoid text shown sideways, at an angle or distorted in any way, such as by being wrapped round a real or virtual object in the commercial.
- Complexity is another factor that determines legibility of the text. There are two kinds of complexity, that of the offer itself and the way the offer is presented. The two elements are closely related but these guidelines are targeted primarily at the second, the communication of the message.



*Notes* Use black and yellow for a billboard advertisement to make it easy to read. Know how to use professional design programs such as Adobe Creative Suite.

### 2.2.6 Significance of Text Based Advertising

- Since the text ads are more of keyword oriented, they draw more attention than banner advertising.
- The text ads are inexpensive, thus making it affordable and effective for your business.
- There are a few websites which offers a flat free rental services to place your text based advertisements.
- A few websites request for a onetime payment to place your text ads.
- The foremost benefit of having text based advertisements is that it helps in improving your search engine ranking.
- Since it creates more visibility and draws more traffic to your site, your page rank will be improved.

Thus, text ads will help in making your business a successful venture.

## **2.3 Font Editing and Design Tools**

A font editor is a class of application software specifically designed to create or modify font files. Font editors differ greatly depending on if they are designed to edit bitmap fonts or outline fonts. Most modern font editors deal with the outline fonts. Special font editing tools can be used to make your own type, so you can communicate an idea or graphic feeling exactly. With these tools, professional typographers create distinct text and displays faces.

### **2.3.1 ResEdit**

- ResEdit is a source editor available from apple that is useful for creating and changing graphic resource such as cursors, icons, dialog boxes, patterns, keyboard maps, and bitmapped fonts on the Macintosh.
- It can be used to edit or create new font resources for storing the bitmaps of screen fonts.

### **2.3.2 Fontographer**

- Fontographer is a powerful font editor supplied by Macromedia, is a specialized graphics editor for both Macintosh and Windows platforms.
- You can use it to develop PostScript, TrueType and bitmapped fonts for Macintosh, Windows, DOS, NeXT, and Sun workstations.
- Designers can also modify existing typefaces, incorporate PostScript artwork, automatically trace scanned images, and create designs from scratch.
- Fontographer's features include a freehand drawing tool to create professional and precise in-line and outline drawings of calligraphic and script characters.
- Fontographer allows the creation of multiple font designs from two existing typefaces, and you can design lighter or heavier fonts by modifying the weight of an entire typeface.
- Fonts can be condensed, expanded, scaled, rotated, and skewed to create new unique typefaces.
- A metric window provides complete control over character width, spacing, offset, and kerning.

### **2.3.3 Type-Designer**

- Type-Designer for windows from DS Design is a font editor that lets you create, convert, and manipulate PostScript Type1 and TrueType fonts as well as EPS file format illustrations.
- An extensive palette of editing tools allows you to make changes to a font's outline.
- With Type-Designer you can open up to eight typefaces simultaneously and cut and paste characters between them.

### **2.3.4 Font Monger**

- Font Monger from Ares Software offers a proprietary hinting technology to ensure that your fonts will look good regardless of size.
- To create new fonts or to manipulate existing ones, Font Monger includes a freehand drawing tool, a scissors tool, and a gizmo tool that rotates, slants, and skews character outlines.

- Font Monger converts Macintosh or PC fonts to either platform as well as in any direction between PostScript Type 1, Type 3, and True Type formats.
- It allows you to edit and expand the font of small caps, oblique, subscript or superscript characters.
- Font Monger will also save the previous original characters in the PostScript font so you can modify it further in the future, or, if you wish to save on disk space, compress the font and it will remove the extra information.
- Font Monger does not allow editing of the actual outlines of a font but it allows many other functions such as the ability to copy characters between fonts, perform various transformations to any or all characters of a font, and create a variety of composite characters such as fractions and accented characters.

### 2.3.5 Cool 3D Text

Cool 3D Production Studio is a program for creating and animating 3D text and graphics, for videos and other multimedia products. This software runs on Windows 98SE/ ME/2000/XP. With this program, a user can create 3D graphics, animations for videos. It includes new modelling tools, animations plugs-in, and new features for animation and video.

### 2.3.6 Font Chameleon

- Font Chameleon from Ares software for both Macintosh and Windows platforms builds millions of different fonts from a single master font outline.
- The program provides a number of pre-set font descriptors, which you build into a PostScript Type 1, or True Type Font.
- With slide bars you can manipulate various aspects of the font, including its weight, width, x-height, ascenders and descenders, and the blend of the serifs.
- The fonts you do build from the master outline can be used on the Macintosh, Windows, or OS/2 platforms.

### 2.3.7 Making Pretty Text

- To make your text look pretty, you need a toolbox of fonts and special graphics applications that can stretch, shade, shadow, colour, and anti-alias your words into real artwork.
- Most designers find it easier to make pretty type starting with ready-made fonts, but some will create their own custom fonts using font-editing and design tools such as Fontographer, Type-designer, and Font Monger.

## Self Assessment

State whether the following statements are true or false:

1. Fontographer save the previous original characters in the PostScript font.
2. Antique Olive is a font that is suitable for print.
3. Font editing tool is used to create a special symbol and use it in the whole text.
4. Verdana is not an example of serif font.

Notes

5. Cool 3D allows a user to edit and expand the font of small caps, oblique, subscript or superscript characters.
6. Tiresias and Univers 45 are widely used for subtitles in films and documentaries.
7. A serif is a family of graphic characters that usually includes many type sizes and styles.
8. Fontographer allows the creation of multiple font designs from two existing typefaces.
9. The spacing between character pairs is called leading.
10. A typeface is a family of many characters often with many type sizes and styles.

## 2.4 Hypermedia and Hypertext

Hypermedia information spaces are connected by non-linear links which a user may follow in any order. Multimedia information spaces are arranged sequentially, with only one path through the information provided.



*Example:* Educational television tends to be the prime example of multimedia information.

Hypertext is different from normal text in that it is nonlinear. The reader need not read a document from beginning to end, but can jump around within the document by clicking on hot spots (or hyperlinks) in the text.



*Example:* Hypertext systems include web pages and Windows help pages.

On the other hand, hypermedia involves more than simply hyperlinked text. It also incorporates images, sounds, and video into the document. This allows for a more graphical interface to information. Most web pages should be considered hypermedia instead of simply hypertext.

The function of hypertext is to build links and generate an index of words. The index helps to find and group words as per user's search criteria. Hypertext systems are very useful in multimedia interactive education courseware. Hypertext systems provide both unidirectional and bi-directional navigation. Navigations can be through buttons or through simple, plain text. The simple and easy navigation is through linear hypertext where information is organized in linear fashion. Nonlinear hypertext, however, is the ultimate goal of effective navigation.

Individual chunks of information are usually referred to as documents or nodes, and the connections between them as links or hyperlinks the so-called node-link hypermedia model. The entire set of nodes and links forms a graph network. A distinct set of nodes and links which constitutes a logical entity or work is called a hyperdocument – a distinct subset of hyperlinks is often called a hyperweb.

A source anchor is the starting point of a hyperlink and specifies the part of a document from which an outgoing link can be activated. Typically, the user is given visual cues as to where source anchors are located in a document (for example, a highlighted phrase in a text document). A destination anchor is the endpoint of a hyperlink and determines what part of a document should be on view upon arrival at that node (for example, a text might be scrolled to a specific paragraph). Often, an entire document is specified as the destination and viewing commences at some default location within the document (for example, the start of a text). Figure 2.8 illustrates these concepts graphically.

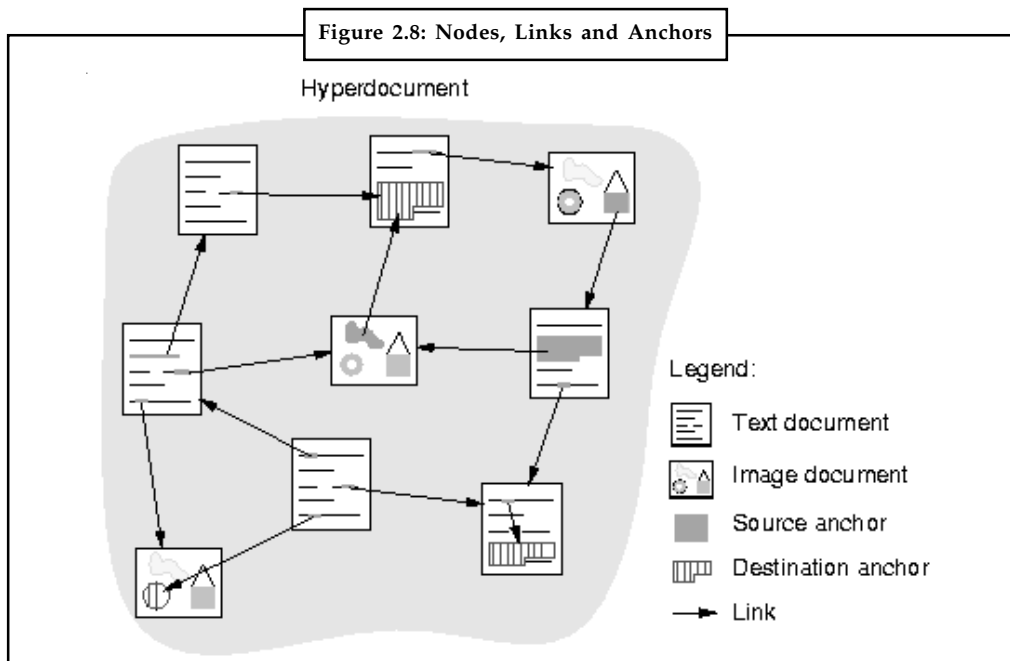

Source: <http://www.iicm.tugraz.at/Ressourcen/Archive/hgbook/images/img3.gif>

### 2.4.1 Referential and Organisational Links

Some authors distinguish between referential and organizational hyperlinks. Referential links are the cross-references distinctive of hypermedia. Organizational links are special links which establish explicit structure by connecting a parent node with its children, forming a tree within the overall node-link graph.

#### Using Hypertext Systems

- Information management and hypertext programs present electronic text, images, and other elements in a database fashion.
- Software robots visit Web pages and index entire Web sites.
- Hypertext databases make use of proprietary indexing systems.
- Server-based hypertext and database engines are widely available.
- Software robots visit Web pages and index entire Web sites.
- Hypertext databases make use of proprietary indexing systems.
- Server-based hypertext and database engines are widely available.
- Information management and hypertext programs present electronic text, images, and other elements in a database fashion.

#### Searching for Words

Typical methods for word searching in hypermedia systems are as follows:

- Categorical search

## Notes

- Adjacency
- Word relationship
- Alternates
- Frequency
- Association
- Truncation
- Negation
- Intermediate words

## Hypermedia Structures

- Links
- Nodes
- Anchors
- Navigating hypermedia structures

## Nodes

- Nodes are accessible topics, documents, messages and content elements.
- Nodes and links form the backbone of a knowledge access system.



*Did u know?* Links are connections between conceptual elements and are known as navigation pathways and menus.

## Anchors

- Anchor is defined as the reference from one document to another document, image, sound, or file on the Web.
- The destination node linked to the anchor is referred to as a link end.
- The source node linked to the anchor is referred to as a link anchor.

## Navigating Hypermedia Structures

- Location markers must be provided to make navigation user-friendly.
- The simplest way to navigate hypermedia structures is via buttons.

## Hypertext Tools

- Two functions common to most hypermedia text management systems are building (authoring) and reading.

The functions of 'builder' are:

- Generating an index of words

- Identifying nodes
- Creating links

Hypertext systems are used for:

- Technical documentation
- Electronic catalogues
- Interactive kiosks
- Electronic publishing and reference works
- Educational courseware

### 2.4.2 Nodes, Links and Navigation

Sometimes a physical web page behaves like two or more separate chunks of content. The page is not the essential unit of content in websites built with Flash (an animation technology from Macromedia) and in many non-web hypertext systems. Hence, the term node is used as the fundamental unit of hypertext content. Links are the pathways between nodes.

When a user clicks links a succession of web pages appear and it seems that a user is navigating the website. For a user, exploring a website is much like finding the way through a complex physical environment such as a city. The user chooses the most promising route and if get lost, he may backtrack to familiar territory or even return to home page to start over.

A limitation of the navigation is that it does not correspond to the full range of user behaviour. Majority of users click the most promising links they see which has forced the web designers to create links that would attract users.

### 2.4.3 Information Structures

Website designers and other hypertexts must work hard to decide which nodes will be linked to which other nodes. There are familiar arrangements of nodes and links that guide designers as they work. They are called information structures. Hierarchy, web-like and multi-path are three of the most important of these structures.

#### Hierarchical Structure

The hierarchy is the most important structure because it is the basis of almost all websites and most other hypertexts. Hierarchies are orderly (so users can grasp them) and yet they provide plenty of navigational freedom. Users start at the home page, descend the branch that most interests them, and make further choices as the branch divides. At each level, the information on the nodes becomes more specific. Notice that branches may also converge.



*Notes* There is almost always a link from every node back to the home page (the top of the hierarchy) and other kinds of upward links.

When designing larger hypertexts, website designers must choose between making the hierarchy broader (putting more nodes on each level) or deeper (adding more levels). One well-established design principle is that users more easily navigate a wide hierarchy (in which nodes have as many as 32 links to their child nodes) than a deep hierarchy.

Notes

You may have recognized that a great many print documents are hierarchies in one significant respect. They are often divided into hierarchical divisions like parts, chapters, sections and subsections. These divisions create a logical hierarchy that the user encounters while reading linearly. Cross references in print invite the reader to jump from one part of the document to another and so are analogous to links in hypertext.

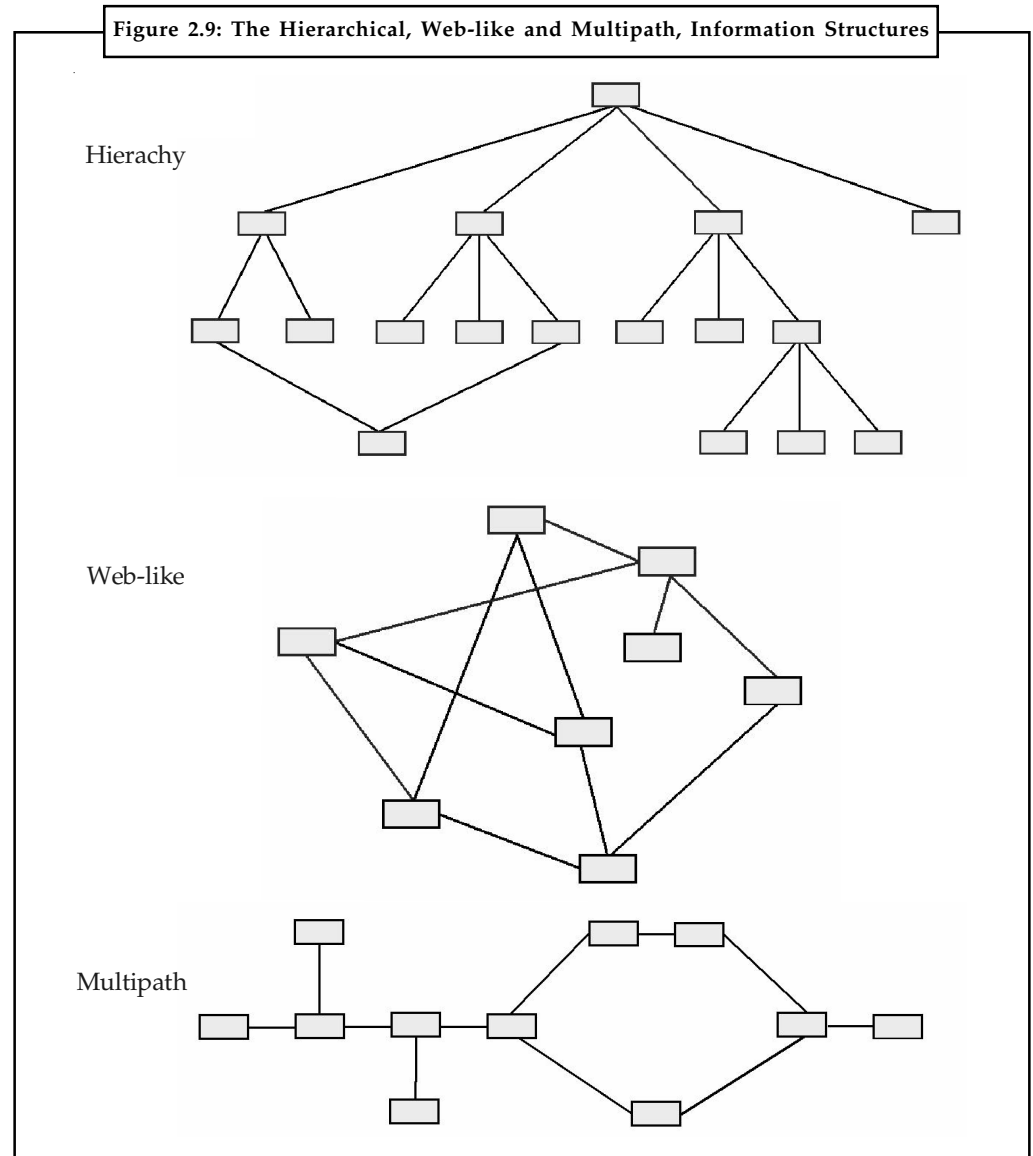

**Web-like Structures**

Nodes can be linked to one another in web-like structures. There are no specific designs to follow but web designers must take care in deciding which links will be most helpful to users. Many structures turn into a hierarchical structure and cause trouble to users in navigating them. This is why few web-like websites and non-web hypertexts are made.

Many web-like hypertexts are short stories and other works of fiction, in which artistic considerations may override the desire for efficient navigation.



## Multi-path Structures

## Notes

As shown in Figure 2.9, it is possible to build a sequence of nodes that is in large part linear but offers various alternative pathways. This is called multi-path structure. Users find multi-path structures within hierarchical websites. For instance, a corporate website may have a historical section with a page for each decade of the company's existence. Every page has optional digressions, which allows the user to discover events of that decade.



*Task* Create a multi-path structure for a hypertext.

### 2.4.4 Future Developments

Computing and the web will continue to evolve in a great many ways. Monitors may give way to near-eye displays, at least for mobile computing. Virtual reality may become more widespread and may be routinely incorporated into the web.

For instance, websites may provide much improved site maps consisting of a 3D view of the site structure, maybe using the metaphor of galaxies and solar systems. The web may well become more intelligent and capable of generating personalized links that really match users interest. The web may also become more social as users click links that open up live audio or video sessions with another user. As communications medium changes, theory must keep pace. Or else it becomes increasingly difficult to understand the medium and design successfully for it.

### Self Assessment

Choose the correct option to answer the following:

11. The little decoration at the end of a letter stroke is a .....
  - (a) Sans-serif
  - (b) Serif
  - (c) New Century SchoolBook
  - (d) Helvetica
12. Web pages are coded using .....
  - (a) Unicode
  - (b) ASCII
  - (c) Hypertext Markup Language
  - (d) Encapsulated PostScript
13. Hypertext systems are not used for .....
  - (a) Technical documentation
  - (b) Electronic catalogues
  - (c) Interactive kiosks
  - (d) Navigating hypermedia structures
14. .... hypertext and database engines are widely available.
  - (a) Server-based
  - (b) Web based
  - (c) Interactive
  - (d) Hierarchical
15. Which of following is the simplest ways to navigate hypermedia structures?
  - (a) Links
  - (b) Nodes
  - (c) Buttons
  - (d) Keys

Notes



Case Study

## Multimedia Kiosk

**C**ompany worked on a project to develop a kiosk-based integrated multimedia service for the general public. The purpose of the kiosk was to provide users with information about unemployment benefits, and job and training opportunities. It was specifically aimed at the unemployed, and made no assumptions about the users' having knowledge of computers or technology in general. The company had no experience of usability and a limited budget, but felt that usability issues were important and hired the services of a usability consultancy.

Usability testing and evaluation was carried out during the development of the kiosk, with the intention of identifying any significant design problems and providing timely and concise input into the development process. The methods used were:

- User survey and profiling
- Walkthrough evaluation
- Usability testing
- User field trials.

The user survey and profiling provided important preliminary information about the users that was useful at the design stage. For example, it confirmed that the target audience would be capable of interacting with a computer system that had basic text information, and it provided information about features that the target audience would see as important if they were going to use the system instead of queuing to talk to an information officer.

The walkthrough evaluation consisted of an expert evaluation and a user walkthrough with a usability expert. Several difficulties were identified and, as a result, the design team realized the danger of assuming the users' level of domain knowledge, and recognized the need for screen layout consistency, the simplification of user tasks, and giving the users a model of the system structure (e.g., a menu structure overview).

The first usability test was carried out in the consultant's usability testing lab and the participants completed a predefined set of task scenarios that reflected the intended usage of the system. The results of the test provided a focus for future design efforts, by identifying the characteristics of the system that the users felt were most important; and provided a baseline against which the quality of the kiosk could be assessed. The design team was able to improve the quality of the application from the detailed design recommendations that were made and broke down the complex procedural tasks into simple units of work with immediate access to support information.

The system was redesigned on the basis of the results of the first usability test. The tasks in the second usability test were identical to those of the first test. The second usability results showed that the redesign of the system resulted in 70% reduction of the number of problems experienced by participants in the first usability test. This showed that the redesign of the user interface had significantly improved the usability of the system, supporting the positive contribution that can be made by usability testing as part of an iterative design process.

The third usability test was conducted in the Department of Social Welfare. The participants performed identical tasks, but half of them used the system with the aid of an online user assistant agent. The results of the tests clearly showed the benefits of the online assistant

*Contd....*

## Notes

in helping the participants achieve their goals, and that there were no usability problems that prevented the respondents from using the system when they had access to the online assistant. The improved attitude towards the system, and the respondents' ability to use the system without direct help provided reassurance to the development team that, with minor redesigns, the system was ready for User Trials.

User Trials confirmed that the general public perceived the kiosk as a useful method of distributing Social Welfare, job search and training services. It provided background information for how the system might be used in a public location.

In conclusion, the usability consultants' involvement throughout the development process helped influence the design as problems were identified and fixed at an early stage. Each test showed an improvement in the efficiency of the system, so the usability testing made a positive contribution to the quality of the product.

**Questions:**

1. Critically analyse multimedia kiosks in general.
2. Have you ever worked on multimedia kiosk? What was your experience like?

Source: <http://www.ucc.ie/hfrg/emmus/case/case7.htm>

**2.5 Summary**

- Text is one of the most important elements of multimedia.
- The standard document format used for Web pages is called HTML.
- Multimedia is the combination of text, graphics, and audio elements into a single presentation.
- A hypertext system enables the user to navigate through text in a non-linear way.
- Dynamic HTML uses Cascading Style Sheets (CSS) for greater control over design.
- Hypermedia information spaces are connected by nonlinear links which a user may follow in any order.
- In hypertext a reader need not read a document from beginning to end, but can jump around within the document by clicking on hot spots (or hyperlinks) in the text.
- The familiar arrangements of nodes and links that guide designers as they work are called information structures.
- Hierarchy, web-like and multipath are three of the most important information structures.

**2.6 Keywords**

**Bitmapped Font:** A font that stores each glyph as an array of pixels that is a bitmap.

**Glyph:** A graphic representation of a character's shape where a character may be represented by many glyphs.

**Hyperdocument:** A distinct set of nodes and links which constitutes a logical work.

**Hyperlink:** A link from a hypertext document to another location, activated by clicking on a highlighted word or image.

**Hyperweb:** A distinct subset of hyperlinks.

**Typeface:** A family of many characters often with many type sizes and styles.

Notes

**2.7 Review Questions**

1. List out the differences between serif and sans-serif fonts and give examples of each.
2. Discuss differences among multimedia, hypermedia, interactive media and hypertext.
3. Explain font and typeface with examples.
4. What do you understand by font editing and design tools? Explain in brief.
5. Explain the terms given below:
  - (a) Node
  - (b) Anchor
  - (c) Links
6. Write in brief about software that are used for editing and creating fonts.
7. What things should be keep in mind while choosing a text font for a multimedia project?
8. Explain information structure in brief.
9. Write a note on “Importance of text based advertising”.
10. Write a note on the terms given below:
  - (a) Font monger
  - (b) Fontographer

**Answers: Self Assessment**

- |          |          |
|----------|----------|
| 1. False | 2. False |
| 3. True  | 4. True  |
| 5. False | 6. True  |
| 7. False | 8. True  |
| 9. False | 10. True |
| 11. (b)  | 12. (c)  |
| 13. (d)  | 14. (a)  |
| 15. (c)  |          |

**2.8 Further Readings**



Books

Frederick P. Brooks, Jr., Kenan Professor of Computer Science. *The Mythical Man-Month: Essays in Software Engineering*. University of North Carolina at Chapel Hill.

K. Andleigh and K. Thakkar. *Multimedia System Design*. PHI, PTR.

Steve Rimmer (2000). *Advanced Multimedia Programming*. MHI.

Tay Vaughan, *Multimedia Making it work*, Seventh Edition, Tata McGraw-hill Education Private Ltd.

Notes



Online links

<http://piotech.wsd.wednet.edu/techoneunits/3presentations/1intro/multimediaIntro.html>

<http://web.cs.wpi.edu/~kal/elecdoc/MMtext.html>

<http://www.cil.utm.my/publications/manuals/imedia/media/text/>

## Unit 3: Sound

### CONTENTS

Objectives

Introduction

3.1 Multimedia System Sounds

3.2 Digital Audio

3.2.1 Preparing Digital Audio Files

3.2.2 Types of Digital Audio File Formats

3.2.3 Editing Digital Recordings

3.3 MIDI Audio

3.3.1 Advantages of MIDI

3.4 Audio File Formats

3.4.1 Uncompressed Audio File Formats

3.4.2 Lossless Compressed Audio Formats

3.4.3 Open File Formats for Storing Digital Data

3.4.4 Proprietary File Formats and Different Formats

3.5 MIDI versus Digital Audio

3.6 Audio CD Playback

3.7 Audio Recording

3.7.1 Types of Storage

3.7.2 Audio Recording Guidelines

3.8 Voice Recognition and Response

3.8.1 Using Microphone

3.8.2 Performance Features

3.9 Summary

3.10 Keywords

3.11 Review Questions

3.12 Further Readings

### Objectives

After studying this unit, you will be able to:

- Describe multimedia system sounds
- Understand digital audio
- State the MIDI audio

- Enumerate audio file formats
- Explain MIDI versus digital audio
- Discuss audio CD playback
- Understand audio recording
- Explain voice recognition and response

## Introduction

We acquire a great deal of knowledge through our ears. Many multimedia developers take advantage of this sense by incorporating sound into their multimedia products. Sound enhances a multimedia application by supplementing presentations, images, animation, and video. In the past, only those who could afford expensive sound recording equipment and facilities could produce high-quality, digital sound. Today, computers and synthesizers make it possible for the average person to produce comparable sound and music.

Sound is the terminology used in the analogue form, and the digitized form of sound is called as audio. A sound is a waveform. It is produced when waves of varying pressure travel through a medium, usually air. It is inherently an analogous phenomenon, meaning that the changes in air pressure can vary continuously over a range of values.

### 3.1 Multimedia System Sounds

All computers are equipped with basic sounds such as beeps, dings and random startup sounds. However, in order to hear more sophisticated sounds (music and speeches), a user will need a sound card and either speakers or headphones.



*Did u know?* All Macs, PC's and laptops come with a sound card already installed. It enables a computer to play and record sounds.

To see if a sound card installed on the machine, click Start! Settings! Control Panel and look for an icon called "Multimedia" or "Sounds". Double-click on the icon to view your sound card information. To place a speaker icon in the bottom right hand tray, check the "Show Volume Control on Taskbar" box. To adjust the volume, double-click on the speaker icon and slide the Balance bar either up (louder) or down (quieter). Some laptops also have an external volume control knob.

To test the sound and volume on the computer, go on Start! Settings! Control Panel! Sounds. Choose one of the computer's built-in sounds (i.e. Default Beep) and click the play arrow next to the name. If a user can't hear the sound, or if the sound is too low, adjust the volume accordingly.

### 3.2 Digital Audio

The sound recorded on an audio tape through a microphone or from other sources is in an analogue (continuous) form. The analogue format must be converted to a digital format for storage in a computer. This process is called digitizing. The method used for digitizing sound is called sampling.

Digital audio represents a sound stored in thousands of numbers or samples. The quality of a digital recording depends upon how often the samples are taken. Digital data represents the

Notes

loudness at discrete slices of time. It is not device dependent and should sound the same each time it is played. It is used for music CDs.

### 3.2.1 Preparing Digital Audio Files

Read the steps given below to prepare digital audio files:

- Balancing the need for sound quality against available RAM and hard disk resource.
- Setting appropriate recording levels to get a high quality and clean recording.
- To digitize the analogue material recording it into a computer readable digital media.

The sampling rate determines the frequency at which samples will be drawn for the recording. The number of times the analogue sound is sampled during each period and transformed into digital information is called sampling rate. Sampling rates are calculated in Hertz (HZ or Kilo HZ). The most common sampling rates used in multimedia applications are 44.1 KHZ, 22.05 JHZ and 11.025 KHZ. Sampling at higher rates more accurately captures the high frequency content of the sound. Higher sampling rate means higher quality of sound. However, a higher sampling rate occupies greater storage capacity. Conversion from a higher sampling rate to a lower rate is possible.



*Did u know?* Audio resolution determines the accuracy with which a sound can be digitized.

### Sound Bit Depth

Sampling rate and sound bit depth are the audio equivalent of resolution and colour depth of a graphic image. Bit depth depends on the amount of space in bytes used for storing a given piece of audio information. Higher the number of bytes higher is the quality of sound. Multimedia sound comes in 8-bit, 16-bit, 32-bit and 64-bit formats. An 8-bit has 28 or 256 possible values. A single bit rate and single sampling rate are recommended throughout the work. An audio file size can be calculated with the simple formula:

$$\text{File Size in Disk} = (\text{Length in seconds}) \times (\text{sample rate}) \times (\text{bit depth}/8 \text{ bits per byte}).$$

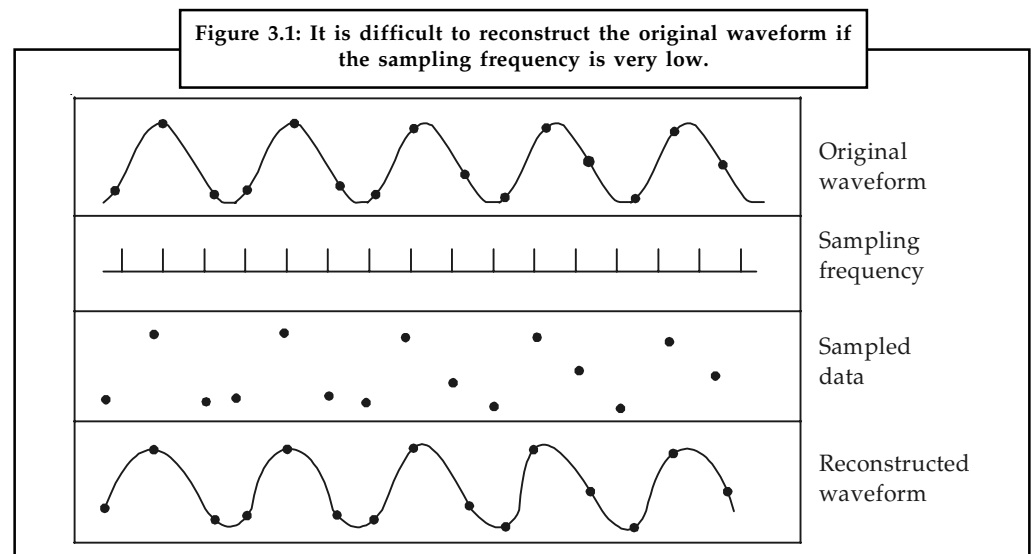

Source: Multimedia: Making It Work, By Tay Vaughan page 100



## Notes

Bit Rate refers to the amount of data, specifically bits, transmitted or received per second. It is comparable to the sample rate but refers to the digital encoding of the sound. It refers specifically to how many digital 1s and 0s are used each second to represent the sound signal. This means the higher the bit rate, the higher the quality and size of your recording. For instance, an MP3 file might be described as having a bit rate of 320 kb/s or 320000 b/s. This indicates the amount of compressed data needed to store one second of music.

$$\text{Bit Rate} = (\text{Sample Rate}) \times (\text{Bit Depth}) \times (\text{Number of Channels})$$



*Example:* The standard audio CD is said to have a data rate of 44.1 kHz/16, implying the audio data was sampled 44,100 times per second, with a bit depth of 16. CD tracks are usually stereo, using a left and right track, so the amount of audio data per second is double that of mono, where only a single track is used. The bit rate is then 44100 samples/second  $\times$  16 bits/sample  $\times$  2 = 1,411,200 bit/s or 1.4 Mbit/s.

### Mono or Stereo

Mono sounds are flat and unrealistic compared to stereo sounds, which are much more dynamic and lifelike. However, stereo sound files require twice the storage capacity of mono sound files. Therefore, if storage and transfer are concerns, mono sound files may be the more appropriate choice.

Formula for determining the size of the digital audio is given below:

$$\text{Monophonic} = \text{Sampling rate} \times \text{duration of recording in seconds} \times (\text{bit resolution}/8) \times 1$$

$$\text{Stereo} = \text{Sampling rate} \times \text{duration of recording in seconds} \times (\text{bit resolution}/8) \times 2$$



*Notes* Keep the following things in mind:

- The sample size is the amount of information stored and is called as bit resolution.
- The time span of the recording is measured in seconds.
- The number of channels is two for stereo and one for monophonic.

### Analogue verses Digital

There are two types of sound – analogue and digital. Analogue sound is a continuous stream of sound waves. To be understood by the computer, these sound waves must be converted to numbers. The process of converting analogue sounds into numbers is called digitizing or sound sampling. Analogue sounds that have been converted to numbers are digital sounds. When we are working with digital sound, we call it audio. Therefore, sound that has been converted from analogue to digital is often called digital audio sounds. Non-destructive sound processing methods maintain the original file. A copy of the original file can be manipulated by playing it louder or softer, combining it with other sounds on other tracks, or modifying it in other ways.



*Caution* Using non-destructive processing, the original file should remain untouched in case it is needed at a later time.

**Notes**

Once a sound has been recorded, digitized, processed, and incorporated into a multimedia application, it is ready to be delivered. So that you can hear it through your speakers, the digital sound is sent through a digital-to-analogue converter (DAC).

**Delivery System**

The delivery system will vary as the intended audience of the multimedia application changes. When considering the delivery of sound, you should consider the number of different sounds that will be delivered, how they will be delivered, where they will be delivered, and to whom they will be delivered. In other words, the application may include one voice and some background music designed for one user in front of a desktop computer or it may be a presentation with various different types of music, narration, and special effects designed for a larger audience to be presented in an auditorium. Regardless, a high quality delivery system will help ensure that the sounds you've worked hard to create make the right impression.

**3.2.2 Types of Digital Audio File Formats**

There are many different types of digital audio file formats that have resulted from working with different computer platforms and software. Some of the better known formats include:

**WAV**

WAV is the Waveform format. It is the most commonly used and supported format on the Windows platform. Developed by Microsoft, the Wave format is a subset of RIFE RIFF is capable of sampling rates of 8 and 16 bits. With Wave, there are several different encoding methods to choose from including Wave or PCM format. Therefore, when developing sound for the Internet, it is important to make sure you use the encoding method that the player you're recommending supports.

**AU**

AU is the Sun Audio format. It was developed by Sun Microsystems to be used on UNIX, NeXT and Sun Sparc workstations. It is a 16-bit compressed audio format that is fairly prevalent on the Web. This is probably because it plays on the widest number of platforms.

**RA**

RA is Progressive Networks RealAudio format. It is very popular for streaming audio on the Internet because it offers good compression up to a factor of 18. Streaming technology enables a sound file to begin playing before the entire file has been downloaded.

**AIFF**

AIFF or AFF is Apple's Audio Interchange File Format. This is the Macintosh waveform format. It is also supported on IBM compatibles and Silicon Graphics machines. The AIFF format supports a large number of sampling rates up to 32 bits.

**MPEG**

MPEG and MPEG2 are the Motion Picture Experts Group formats. They are a compressed audio and video format. Some Web sites use these formats for their audio because their compression capabilities offer up to a factor of at least 14:1. These formats will probably become quite

widespread as the price of hardware based MPEG decoders continues to go down and as software decoders and faster processors become more mainstream. In addition, MPEG is a standard format.

## MIDI

MIDI (MID, MDI, MFF) is an internationally accepted file format used to store Musical Instrument Digital Interface (MIDI) data. It is a format used to represent electronic music produced by a MIDI device (such as a synthesizer or electronic keyboard). This format provides instructions on how to replay music, but it does not actually record the waveform. For this reason, MIDI files are small and efficient, which is why they are often used on the Web.

## SND

SND is the Sound file format developed by Apple. It is used mainly within the operating system and has a limited sampling rate of eight bits.

For a multimedia application to work on both PCs and Macs, save it using either the Musical Instrument Digital Interface (MIDI) or the Audio Interchange File Format (AIFF) file format. It is recommended to use AIFF format if sound is a part of the application. AIFF is a cross-platform format and it can also reside outside the multimedia application. Now the file occupies less space and play faster. Moreover, if a user wants to burn the multimedia application onto a CD, AIFF format can be used.

## Digital Recordings

In digital recording, digital sound can be recorded through microphone, keyboard or DAT (Digital Audio Tape). To record with the help of a microphone connected to a sound card is avoided because of sound amplification and recording consistency. Recording on a tape recorder after making all the changes and then through sound card is recommended.

### 3.2.3 Editing Digital Recordings

#### Sound Editors

Sound editors are responsible for creating sound, transforming file formats and enhancing the quality of sound by cutting the noise. Sound Edit 16, Cool Edit and Sound Forge are three commonly used sound editors in multimedia applications. Sound Edit 16 allows a user to record, edit and transform digital audio effortlessly in a lesser time whereas Cool Edit is a low cost software that is easy to use giving a reasonably good quality of sound. On the other hand, Sound Forge is regarded as the best software for audio recording and editing for PCs.

Read below the various sound editing operations used in multimedia operations:

- One of the first sound editing operations is to delete any blank space from the beginning and end of the recording. This is called trimming. Using this function a sound editor can also remove any extraneous noises that might have crept in while recording.
- One of the most important functions that a software should do is to perform multiple tasks. It should be capable to combine and edit multiple tracks, merge and export them in a single audio file.
- Volume adjustment is another important task when a sound recorder is trying to combine ten tracks into a single track as the tracks may have different volume.

**Notes**

- Sound editors have to perform format conversion when the digital audio editing software read a format different from the format read by the presentation program.
- If the sound editor edits and records sounds at 16 bit sampling rates but is using lower rates then he must resample or downsample the file.
- Some editing software provide digital equalization capabilities that let a sound editor revise a recording frequency content so that it sounds brighter or darker.
- Some programs allow a sound editor to process the signal with reverberation, multi-tap delay, and other special effects using Digital Signal Processing routines.
- To produce a surreal sound, sound editors reverse all or a portion of a digital audio recording.
- Advanced programs let you alter the length of a sound file without changing its pitch. This feature can be very useful but watch out because most time stretching algorithms will severely degrade the audio quality.

### **3.3 MIDI Audio**

The MIDI (Musical Instrument Digital Interface) is a connectivity standard that musicians use to hook together musical instruments (such as keyboards and synthesizers) and computer equipment. Using MIDI, a musician can easily create and edit digital music tracks. The MIDI system records the notes played, the length of the notes, the dynamics (volume alterations), the tempo, the instrument being played, and hundreds of other parameters, called control changes.

Because MIDI records each note digitally, editing a track of MIDI music is much easier and more accurate than editing a track of audio. The musician can change the notes, dynamics, tempo, and even the instrument being played with the click of button. Also, MIDI files are basically text documents, so they take up very little disk space. The only catch is that you need MIDI-compatible hardware or software to record and playback MIDI files. MIDI provides a protocol for passing detailed descriptions of musical scores, such as the notes, sequences of notes, and what the instrument will play these notes.

A MIDI file is very small, often as small as 10 KB for a 1-minute playback (a .wav file of the same duration requires 5 to 10 MB of disk space). This is because it doesn't contain audio waves like audio file formats do, but instructions on how to recreate the music. Another advantage of the file containing instructions is that it is quite easy to change the performance by changing, adding or removing one or more of the instructions – like note, pitch, tempo, and so on – thus creating a completely new performance. This is the main reason for the file to be extremely popular in creating, learning, and playing music.

MIDI actually consists of three distinctly different parts – the physical connector, the message format, and the storage format. The physical connector connects and transports data between devices; the message format (considered to be the most important part of MIDI) controls the stored data and the connected devices; and the storage format stores all the data and information.

Today, MIDI is seen more of a way to accomplish music, rather than a format or a protocol. This is why phrases like “composing in MIDI” and “creating MIDI” are quite commonly used by musicians.

MIDI files may be converted to MP3, WAV, WMA, FLAC, OGG, AAC, MPC on any Windows platform using Total Audio Converter.

### 3.3.1 Advantages of MIDI

Notes

- Since they are small, MIDI files embedded in web pages load and play promptly.
- Length of a MIDI file can be changed without affecting the pitch of the music or degrading audio quality
- MIDI files will be 200 to 1000 times smaller than CD-quality digital audio files. Therefore, MIDI files are much smaller than digitized audio.
- MIDI files do not take up as much as RAM, disk space, and CPU resources.
- A single MIDI link can carry up to sixteen channels of information, each of which can be routed to a separate device.



*Did u know?* MIDI technology was developed in 1983 by a panel of music industry representatives and is maintained by the MIDI Manufacturers Association (MMA).

### Self Assessment

Fill in the blanks:

1. MIDI stands for .....
2. The number of channels is ..... for stereo and ..... monophonic. 2,1.
3. .... is used to convert MIDI files into MP3, WAV, WMA, FLAC, OGG, AAC, MPC on any Windows platform.
4. MIDI technology was developed in ..... by a panel of music industry representatives.
5. The full form of MPEG is .....

### 3.4 Audio File Formats

Audio file formats are formats for storing audio data on a computer system. Generally they are container formats or audio data formats with a defined storage layer, but can be a raw bit stream too. The storage of digital audio involves sampling the audio voltage, which would correspond to a certain level of signal in a channel with a particular resolution in regular intervals, on playback. The data can then be stored uncompressed or compressed. Compression reduces the file size.

To distinguish between a file format and a codec becomes essential here since a codec encodes and decodes the raw audio data and specific audio file format stores the data in a compatible file. Most of the audio file formats are created with one or more encoders or codecs. Generally the audio file formats support only one type of audio data that is created with an audio coder but a multimedia container format may support multiple types of audio and video data.

Audio file formats are classified into three major groups that include:

- Uncompressed audio formats like WAV, AIFF, AU or raw header-less PCM.
- Lossless compressed audio formats like FLAC, Monkey's Audio, WavPack, Shorten, Tom's lossless Audio Compressor, TTA, ATRAC Advanced Lossless, Apple Lossless, MPEG-4 SLS, MPEG-4 ALS, MPEG-4 DST and Windows Media Audio Lossless.
- Lossy compressed formats like MP3, Vorbis, Musepack, AAC, ATRAC and lossy Windows Media Audio.

### 3.4.1 Uncompressed Audio File Formats

Uncompressed audio files are digital representations of soundwave, which are most accurate. However, it can be a resource-intensive method of recording and storing digital audio, in terms of storage and management. They are generally the master audio formats of choice as they are suitable for archiving and delivering audio at high resolution due to their accuracy. They are also suitable when working with audio at a professional level.

PCM is the major uncompressed audio format that is stored as a .wav on Windows or as .aiff on Macintosh operating systems. The aforementioned formats are flexible file formats designed for the storage of any combination of sampling rates or bitrates. The AIFF format is based on the IFF format, and the WAV format on the RIFF file format that is similar to the IFF format. These formats are working formats within many audio, video and multi-media applications, and Digital Audio Workstations employed for professional audio production and editing.

#### File Types

The listed uncompressed audio file types are 'wrapper' formats that use PCM audio and add additional data to enable compatibility with specific codecs and operating systems. Although some of them were developed for specific platforms, they have open-source codecs that are available for all standard operating systems like Windows, MacOS and Linux. The different types include:

#### *The Wave format family*

Microsoft Wave format, commonly known as WAV, is the most widely used uncompressed format. All forms of WAV are PCM wrap formats with .wav as extension and store the audio data in a basic form. To provide compatibility with non-PCM audio streams, the wrapper has been altered over time.

- **WAV (Waveform Audio File Format):** It is a flexible format, capable of storing very high quality audio but can't hold any metadata describing its audio contents and its file size is limited to 4 GB.
- **BWF (Broadcast Wave Format):** This format includes an extra header file that contains metadata about the audio and synchronization information (BEXT chunk). It is the default audio format of some non-linear digital audio/video workstations and has a file size limited to 4 GB.
- **MBWF (Multichannel Broadcast Wave Format):** The recent evolution of Broadcast WAV, MBWF has RF64 audio with a BEXT chunk. It contains up to 18 simultaneous streams of surround audio, non-PCM data streams and a stereo 'mixdown'. The 64-bit address header extends the file size to over 18 billion GB.
- **AIFF:** Audio Interchange File Format was developed by Apple and Amiga and is the native format for audio on Mac OSX.

#### *Technical Attributes*

All uncompressed audio formats share some of the technical attributes like:

Bit Depth – 8-bit, 12-bit, 16-bit and 24-bit.

Sampling Rate - <44.1 kHz, 44.1 kHz, 48 kHz and 96 kHz +.

### 3.4.2 Lossless Compressed Audio Formats

Notes

Audio compression involves data compression to reduce the transmission bandwidth requirement of digital audio streams and the storage size of audio files. Lossless compression produces digital data that can be expanded to an exact duplicate of the original audio stream. Compression ratios of lossless compression formats are similar to those for generic lossless data compression and yield around 50-60 per cent of the original size.

Lossless compressed formats require more processing time when compared to uncompressed formats but are more efficient in space usage. In this format, the music occupies a marginally smaller file and the silence takes up no space at all when being encoded. The format is intended to reduce processing time and maintain a good compression ratio.

The different types of lossless compression formats provide a compression ratio of about 2:1. These types include:

- **FLAC:** Free Lossless Audio Codec is an audio codec for lossless audio data compression. It accomplishes data compression, keeping the integrity of the audio source intact. Audio sources encoded to FLAC are reduced to 50-60% of their original size and a digital audio recording converted by the codec can be decompressed into an identical copy of the audio data. It is suitable for everyday playback and archival and is well-supported by many software applications.
- **WavPack:** It is a free, open source lossless audio compression format that can compress 8-, 16-, 24- and 32-bit floating point audio files in the .wav file format. WavPack can support surround sound streams and high frequency sampling rates. The data reduction rate is generally between 30-70% for popular music and a little better than that for classical music and sources with greater dynamic range.
- **Monkey's Audio:** This file format for audio data compression is employed to reduce bandwidth, file transfer time and storage requirements. A digital recording encoded to this format can be decompressed into an identical copy of the original audio data. The files coded to the format are reduced to about half their original size. The filename extension used by Monkey's Audio files is .ape for audio and .apl for track metadata.
- **ALAC/ Apple Lossless:** The audio codec was developed for lossless data compression of digital music. Apple Lossless data is stored with the filename extension .m4a. The compressed files are about 40-60% the original size depending on the kind of music. Currently, all iPod players can play Apple Lossless-encoded files.

### 3.4.3 Open File Formats for Storing Digital Data

Open file formats are published specifications for storing digital data which can be used and implemented by anyone. These are maintained by a standard organization. An open format can be implemented by both proprietary and free and open source software with the help of typical licenses used by each. Open file formats are published specifications for storing digital data, and open formats are not encumbered by any copyrights, patents, trademarks or other restrictions are known as free file formats.

The different types of open file formats include:

- **gsm:** It was the first digital speech coding standard that was used in the GSM digital mobile phone system. Also known as Full Rate or FR or GSM-FR or GSM 06.10, it has a bit rate of 13.2 kbit/s or 1.65 bits/audio sample. Wav files can also be encoded with the gsm codec and this makes a great compromise between file size and quantity.

Notes

- **dct:** These variable codec audio file formats were designed for dictation by NCH Software. The dictation header information can be encrypted.
- **vox:** It is an audio file format that has been optimized for storing digitized voice data at a low sampling rate. Also known as Dialogic ADPCM, VOX files are commonly found in telephony applications and an occasional arcade redemption game. The format uses the Dialogic ADPCM codec and compresses to 4-bits.
- **aac:** Advanced Audio Coding is a lossy compression and encoding scheme for digital audio, designed to be the successor of the MP3 format. It achieves better sound quality than MP3 albeit at similar bit rates. The format is based on the MPEG2 and MPEG4 standards. These files are generally ADTS or ADIF containers. It is the standard or default audio format for Apple's iPhone, iPod, iTunes.
- **mp4/m4a:** MPEG-4 Part 14 or MP4 file format is a multimedia container format standard that has been specified as a part of MPEG-4. The format is commonly used to store digital video and digital audio streams. They can also be used to store subtitles and still images.
- **mmf:** This is a Samsung audio format used in ringtones.

### 3.4.4 Proprietary File Formats and Different Formats

Proprietary formats are file formats with an opaque presentation of data and unlike open formats; their specifications are not publicly available. They are generally controlled by a private person or organization and can be protected with patents or copyrights. The copyrights provide the exclusive control over the technology to the license holder. These formats are developed by software companies to encode data produced by their applications since they prevent Reverse engineering.

The different types that constitute the format are listed below:

- **mp3:** MPEG-1 Audio Layer 3 (MP3) is an audio-specific encoding format that uses a form of lossy data compression. A common audio format for consumer audio storage, it is popular for downloading and storing music. MP3 files are compressed to around one-tenth the size of an equivalent PCM file and provide good quality audio by eliminating inaudible portions of the audio file.
- **wma:** Windows Media Audio was developed by Microsoft and designed with DRM abilities for copy protection. The audio data compression technology is a proprietary technology and a part of the Windows Media framework. It consists of four distinct codecs - WMA, WMA Pro, WMA Lossless and WMA Voice.
- **atrac:** It is a family of proprietary audio compression algorithms that was developed by Sony. Adaptive Transform Acoustic Coding has a .wav file extension. It is used in many Sony-branded audio players.
- **ra:** Real Audio was developed by RealNetworks and uses a variety of audio codecs. These audio codecs can be used over dialup modems and high-fidelity formats for music. The format can also be used as a streaming audio format that is played at the same time as it is downloaded. They have a .ra file extension.
- **ram:** It is a text file containing a link to the Internet address where the Real Audio file is stored. It has a .ram file extension and doesn't contain any audio data in itself.
- **dss:** Digital Speech Standard files are old and poor codecs. They are Olympus proprietary formats that allow additional data to be held in the file header.



- **msv:** It is a format for voice files that are Memory Stick compressed. It was developed by Sony.
- **dvf:** It is a proprietary format developed by Sony, for compressed voice files. The format is commonly used by Sony dictation recorders.
- **IVS:** The version was developed by 3D Solar UK Ltd. with DRM, for use in music downloaded from Tronme Music Store and interactive music and video player.
- **mp4:** The multimedia container format is a proprietary version of AAC in MP4 with DRM. The format was developed by Apple for music downloaded from iTunes Music Store.
- **iklax:** It is a multi-track digital audio format that allows various actions on musical data, like mixing and volume arrangements.
- **mxp4:** The format allows play of different versions of the same song. The Musinaut proprietary format also allows interactivity sessions between the artist and the end user.
- **3gp:** The multimedia container format contains proprietary formats like AMR, AMR-WB or AMR-WB+ and some open formats too.
- **amr:** The AMR-NB audio is primarily used for speech.
- **awb:** The AMR-WB audio is primarily used for speech.

### 3.5 MIDI versus Digital Audio

- With MIDI, it is difficult to playback spoken dialog, while digitized audio can do so with ease.
- MIDI does not have consistent playback quality while digital audio provides consistent audio quality.
- One requires knowledge of music theory in order to run MIDI while digital audio does not have this requirement.
- MIDI files sound better than digital audio files when played on a high quality MIDI device.
- MIDI data are completely editable—right down to the level to an individual note. You can manipulate the smallest detail of a MIDI composition in ways that are impossible with digital audio.

### 3.6 Audio CD Playback

Audio Compact Disks come in standard format of Compact Disc Digital Audio (CDDA or CD-DA). The standard is defined in the Red Book that contains the technical specifications for all CD formats. The largest entity on a CD is called a track. A CD can contain up to 99 tracks (including a data track for mixed mode discs).

The best part is that you can sort the order in which you want to listen the tracks and continue playing without interruption. If the Auto Insert Notification option is disabled or unavailable, audio compact discs (CDs) are not played automatically. Instead, you must start CD Player and then click Play.

To cause an audio CD to be played as soon as you start CD Player, follow these steps:

1. Insert the CD you want to play into the drive.

**Notes**

2. (Optional) If the CD doesn't start playing or if you want to select a disc that is already inserted, click the arrow below the Now Playing tab, and then click the drive that contains the disc.

Another method to launch an audio CD constitutes the following steps:

1. Right-click the Start button, and then click Explore.
2. Double-click the Programs folder, double-click the Accessories folder, and then double-click the Multimedia folder.
3. Right-click the CD Player icon, and then click Properties.
4. On the Shortcut tab, change the entry in the Target box to read: C:\Windows\Cdplayer.exe/PLAY
5. Click OK.
6. Use the "Stop," "Pause," "Skip next track" and "Previous track" buttons to set your preferences while playing the CD.
7. Select from the Edit play list from the Disc menu in order to change the sequence of the tracks.
8. Adjust the volume by clicking on the "Speakers" icon on the task bar and to adjust the bass, treble and other options go to Equalizer.

To skip songs when playing a CD:

1. To skip a song, click the Next button while the song is playing.
2. The song will be skipped. If repeat play is turned on, the song will not play again during that playback session.
3. If you accidentally skip a song you'd like to hear, double-click the song in the playlist. It will be played immediately and won't be skipped anymore.



*Notes* To eject a disc, right-click the disc in the Navigation pane, and then click Eject.

### **3.7 Audio Recording**

In digital recording, we start with an analogue audio signal and convert it to digital data to be stored. Changes in electrical voltage are encoded as discrete samples. On playback we retrieve the digital data and convert it back to an analogue signal. Here, fidelity is dependent on the quality and function of the Analogue-to-Digital (A-to-D) and the Digital-to-Analogue (D-to-A) converter. Once an audio signal is stored as digital data, the storage media has no effect on the quality of sound.

At the heart of hard-disk recording and editing is digital audio. When we record digitally, sound is converted to an electrical signal by a microphone. That signal is coded into numbers by an analogue-to-digital converter (ADC). The numbers are stored in memory, then played back upon demand by sending the numbers to a digital-to-analogue converter (DAC). The resulting signal is sent through an amplifier and speakers so we hear a reproduction of the original sound. This is illustrated by the animation below:

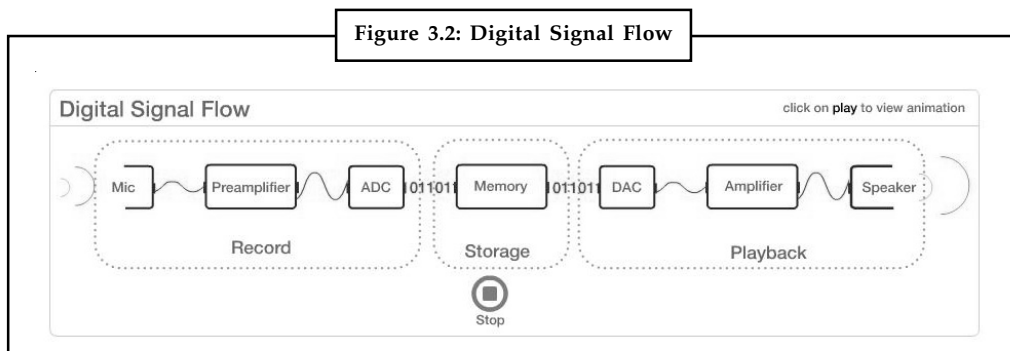

Source: [http://classes.berklee.edu/mbierylo/mtec111\\_Pages/audio\\_rec\\_edit.htm](http://classes.berklee.edu/mbierylo/mtec111_Pages/audio_rec_edit.htm)

### 3.7.1 Types of Storage

Devices used to capture, store and access sound will fall into some combination of the following categories:

- Analogue or digital
- Linear or Random Access, also called non-linear



*Example:* Some examples of the following:

*Cassette Tape* – Linear, Analogue

*Hard Disk Recording* – Random Access, Digital

*DAT Tape* – Linear, Digital

*CD* – Random Access, Digital

*LP (Long-playing Record)* – Random Access, Analogue

Any type of audio recording system has 3 major components:

1. *Input* – Microphone
2. *Storage/retrieval* – Audio Recorder
3. *Output* – Loudspeaker

### 3.7.2 Audio Recording Guidelines

These recommendations are intended to produce the best possible audio recordings. A good audio recording dramatically improves the transcription quality. It lets transcriptionists focus on the finer details, such as researching difficult words and ensuring correct punctuation, rather than trying to discern what was said. This is particularly important in cases with multiple speakers, background noise, complicated vocabulary, or heavy accents.

- Use a high-quality microphone, either a headset microphone or a mounted directional microphone. As a rule of thumb, spending at least \$50 on a microphone is a good investment.
- If a headset microphone is used, be sure that the transducer is at least 13 away from the face and slightly below the lower lip.

**Notes**

- A standing microphone should be placed 9" – 153" directly in front of the speaker. This provides the best trade-off between clarity and risk of over-saturation.
- If there are multiple speakers, providing a separate microphone to each speaker is best. A bi-directional microphone works well for two speakers sitting across from each other at the appropriate distance away from the microphone. The multiple microphone signals should be mixed into a single channel.
- The speaker should not hold or wear the microphone. It should either be a headset mic or be mounted on a stable structure in front of them. This reduces the likelihood that the microphone will move around during recording.
- Use a microphone "pop" filter, either one that comes with the microphone or a separately purchased standing one.
- Calibrate the input level. If your recording device has a VU meter, have the speaker talk naturally – at the appropriate distance from the mic – and make sure the levels are in a good range. If a VU meter is not available, try a sample recording and listen back to make sure the level sounds good.
- Minimize background noise. If you can notice the noise just standing and listening, it will be much worse on the recording. Making a sample recording and listening to it is a good way to discover the noise level. Often, putting soft materials between the microphone and air vents and machinery will block most of the noise.
- Try to eliminate background talking or music. This is a frequent source of poor quality audio.
- Avoid recording in rooms that have a discernible 'echo'. This is especially important if the microphone placement cannot be optimal (i.e. if the microphones are distant from the speaker or speakers). Listening to a recording sample is a good way to see if the echo is a problem. An echo y room will produce "hollow sounding" speech, as if the speaker is at the other end of a tube.
- If the audio input to your recording device allows you to select the sampling rate, choose 16 KHz or higher. If it allows you to select the digital audio sample resolution, choose 16 bits or higher.
- If the audio input to your recording device supports "automatic gain control" ("AGC") or "voice activity detection" ("VAD"), disable this feature.
- Coach your speakers to "speak naturally into the microphone". Do not instruct speakers to over articulate words.

**Media Formats**

- With digital formats becoming more popular, certain mp3 players have the ability to record audio directly into a digital audio format. These devices are small, reliable, and can store massive amounts of audio without the need to switch tapes.
- Mini disc recorders and discs are both compact, easily portable, sturdy and high quality. Using the mini disc recorder for lectures or interviews with an appropriate microphone attachment works well.
- Video cameras are not built specifically for audio recording, however, they nonetheless can record good audio given an appropriate microphone attachment.
- The advantage of recording directly to a computer, of course, is that there is no intermediary media to deal with and you save time. This would most commonly be a choice if you have a laptop or a controlled location like a sound studio.

## Monitor Recordings

## Notes

It is a good idea to always bring headphones with you to monitor the audio. If the equipment you are using has the ability to monitor the recording, as with the Marantz tape decks or higher end video cameras do so.

## 3.8 Voice Recognition and Response

Voice recognition and voice response promise to be the easiest method of providing a user interface for data entry and conversational computing, since speech is the easiest, most natural means of human communication. Voice input and output of data have now become technologically and economically feasible for a variety of applications.

### 3.8.1 Using Microphone

If you plan on doing any type of live recording with your laptop, the first thing you'll need is a microphone. As the first link in the audio chain, a microphone acts as a kind of measuring device which outputs a small, continuously varying AC voltage in response to the changes in atmospheric pressure caused by any sound disturbance.

Figure 3.3: Microphone



Source: [http://upload.wikimedia.org/wikipedia/commons/c/ca/Microphone\\_studio.jpg](http://upload.wikimedia.org/wikipedia/commons/c/ca/Microphone_studio.jpg)

### 3.8.2 Performance Features

There are many makes and models of microphones, each with its own set of characteristics. When evaluating different microphones, there are three important factors to consider:

- **Frequency response** – The range of frequencies a microphone will pick up.
- **Polar pattern** – Indicates how sensitive a microphone is to sound coming from different directions.
  - ❖ *Omni-directional* – picks up sound equally from all directions.
  - ❖ *Cardioid* – Picks up sound from a single direction (on-axis).
    - ◆ Super-cardioid
    - ◆ Hyper-cardioid
  - ❖ *Bi-directional* – Picks up sound from two opposite sides.

Notes

- **Microphone types**
  - ❖ *Dynamic* – Relatively inexpensive, rugged. Exhibits a “proximity effect.” For example Shure SM58
  - ❖ *Condenser* – Very sensitive to fast transients and high frequencies. Requires a source of DC power to operate.
    - ◆ Electret Condensers are generally cheaper versions and come with a charged plate that will lose its charge over time. Generally requires a DC battery to operate a small preamp.
    - ◆ Most professional Condensers require a Phantom power supply. For example AKG 414
  - ❖ *Ribbon* – “smooth” sounding, traditionally somewhat fragile.
  - ❖ *PZM* – Contact microphone which uses another surface as a diaphragm.

These three factors are often integrated in a microphone’s performance characteristics. When shopping for a microphone, look at these specifications, think about what the microphone will be used for, and choose accordingly.



*Task* Make a chart on the performance features of the voice recognition and response.

**Self Assessment**

Choose the correct option to answer the following:

6. .... is an example of uncompressed audio format.
  - (a) MP3
  - (b) AIFF
  - (c) TTA
  - (d) Musepack
7. Which of the following is not a function of monkey’s audio?
  - (a) To reduce bandwidth
  - (b) To reduce file transfer time
  - (c) To reduce storage requirements
  - (d) To support sound streams
8. Which of the following is not an open file format for storing data?
  - (a) MPEG4
  - (b) VOX
  - (c) Windows Media Audio
  - (d) GSM
9. What is the largest entity on a CD called?
  - (a) Track
  - (b) Code
  - (c) Codec
  - (d) Encode
10. Which of the following formats is used in ringtones?
  - (a) DCT
  - (b) GSM
  - (c) MMF
  - (d) CDMA



Case Study

## Dealing With Computer Audio Latency

The small and not-so-small time delays between a signal entering and then emerging from a computer soundcard can turn hard disk recording into a frustrating experience. Martin Walker leads us through the twists and turns of latency.

Latency may sound like something that escaped from a physics lesson at school, but it's real, affects lots of musicians who work with computers and audio, and is extremely frustrating. Only when you experience the problem do you realise why so many people have been bleating on about it for so long.

So just what is it? When you put a new soundcard through its paces, one of the first things you are likely to do is to listen to some of the many real-time effects plug-ins available. You connect your mic, guitar or keyboard, patch in the effect, and then notice a half-second delay before anything happens. So you look for the switch to turn off the delay effect. Only there isn't one. What you're actually hearing is the result of latency, and, worse still, there's no way to get rid of it. At this point, many people wish they'd bought a hardware-based digital recorder instead, and also wonder why these effects are called real-time when they appear to be nothing of the sort.

However, there are ways to minimise latency, though this usually involves making decisions before you choose your soundcard, not afterwards. So please read on. Finding out about latency might just prevent you from buying the wrong soundcard.

### **Latency - The Facts**

Latency is normally thought of as the time delay between inputting a sound and hearing it emerge from the soundcard. However, it also affects playback of existing tracks and the general responsiveness of the application as outlined in the 'Other Effects Of Latency' box elsewhere in the article. The reason that the signal can get so delayed is that it has a long way to go. First, it gets converted from analogue to digital via the converter (a matter of about a millisecond, but a delay nonetheless). Then it passes internally along a digital buss inside the soundcard, and emerges on to the PCI buss (the connector on the edge of every recent soundcard). From here it travels on the motherboard to the rest of the computer, where it meets a huge obstacle – the operating system. Whether Mac or PC, the modern operating system has a great deal to do, and so it does a little bit of everything in turn. As well as processing your audio, the operating system has to do a lot of 'housekeeping' tasks, and to keep everything tidy, it relies on the 'little but often' approach.

To ensure that there are no major glitches in the audio, the soundcard driver software has to be designed to anticipate and cope with any unexpected delays before the operating system deals with the audio. As is always the case with such delays, a small queue of audio data can form, and this slowly backs up in small memory buffers in the soundcard driver until the operating system returns from carrying out its other duties.

As we musicians don't like chunks missing from our audio, software developers include small RAM buffers as part of the sequencer design to hold enough audio data to ensure its smooth delivery. There will be a separate sequencer buffer (or set of buffers) for each enabled input port of your soundcard, and these get topped up by the operating system in fits and starts whenever it gets the chance to grab some more audio from the buffers on the soundcard. As long as there are enough buffers of a big enough size, there will always be enough data in hand to carry on delivering audio to the music application at a smooth and even rate.

Contd....

Notes

**Notes**

The sequencer then carries out lots of number-crunching – especially if you're adding software-based effects and EQ. Finally, the digital signal is sent to another set of buffers – one for each output port of your soundcard – this time to ensure that nothing gets lost on its outward journey. The operating system comes along when it's good and ready, shunts the new digital data stream back across the motherboard, through the PCI edge connector into the soundcard buffers, and it is then clocked out steadily at the chosen sample rate. After another millisecond's worth of conversion time it emerges as an analogue signal from the soundcard output socket.

This is a long journey, the exact length of which depends on the route taken. In the case of a PC, the Windows operating system has a lot of other things to do besides updating its standard Multimedia (MME) soundcard drivers. This means that more and larger buffers are needed to hold the audio data to ensure that nothing is lost. Typically, an application like Cubase VST using the bog-standard MME drivers will have a latency of maybe half a second, depending on your settings. This may not sound like much, but if you remember that it's the same length as a single beat at 120bpm, you can begin to understand why it's such a problem. It means that when you are recording, you can't hear what's being recorded until a beat after it happens. But most people only discover this after they buy a system and set everything up. No wonder they get frustrated!

**Solution**

What's the answer? Does every soundcard suffer from this problem? This is where things get more interesting. As most people would prefer to bypass the problems of latency altogether, I'll start there. As described above, the length of the route taken by the audio signal is largely due to the operating system, and the RAM buffers that are needed to keep the audio stream steady and glitch-free. The way to avoid all these delays is to keep the audio signal on the soundcard for monitoring purposes, and ignore the operating system completely.

Soundcards usually contain some sort of digital mixer. This is either permanently burned into specialist DSP chips (like the Yamaha DSP Factory) or the soundcard uses generic, programmable DSP chips (more often than not by Motorola). In the latter case, the code for the digital mixer is downloaded from your hard drive before it can be used, a process which normally happens as your computer boots up. All the soundcard developer needs to do is provide a way for you to route the signal at the soundcard input socket to one or more of its output sockets – a sort of hardware thru. The route taken by the audio signal then involves merely passing through the A-D converters (about a millisecond), going down a printed circuit board track, and then being converted back into analogue through the D-A converter (another millisecond). And there you are – you can hear your input signal with no more delay than you get when using any outboard effects hardware. If your soundcard features multiple outputs, you can even create several different monitor mixes for individual musicians.

Various soundcard manufacturers have adopted this solution. The Lexicon Studio provides 'Punch Record', complete with its own software-controlled mix level fader, which allows you to bypass the normal monitoring facilities inside applications like Cubase, and directly patch any selected combination of Lexicon Studio input signals through to one of the Lexicon Studio hardware outputs during recording. The MOTU 2408 has its CueMix Console utility, and the Event soundcard range has the Echo Console. The Yamaha DSP Factory has an extremely comprehensive digital mixer offering hardware thru as just one of its many features.

*Contd....*



## Notes

It can be confusing when you launch one of these routing and level control utilities, since many people assume that if it appears on a computer screen then the mechanics are no different from an application like Cubase VST. However, there is actually a big distinction between the two. Audio software such as Cubase VST runs entirely in software, and is therefore subject to operating system delays. The soundcard mixer utility, while it may be controlled using software, is actually a remote control for the DSP-based routing and level controls on the soundcard itself. Although changing the position of any control will be subject to operating system delays, the audio monitoring signals themselves never leave the soundcard, and are therefore entirely independent of the operating system.

**Questions:**

1. Critically analyse computer audio latency.
2. What do you understand by latency? Explain.

Source: <http://www.soundonsound.com/sos/apr99/articles/latency.htm>

### 3.9 Summary

- The method used for digitizing sound is called sampling.
- The sampling rate determines the frequency at which samples will be drawn for the recording. It is calculated in Hertz (HZ or Kilo HZ).
- Bit depth depends on the amount of space in bytes used for storing a given piece of audio information.
- Mono sounds are flat and unrealistic whereas stereo sounds are much more dynamic and lifelike.
- MPEG and MPEG2 are the Motion Picture Experts Group formats. They are a compressed audio and video format.
- Sound Edit 16, Cool Edit and Sound Forge are three commonly used sound editors in multimedia applications.
- The MIDI (Musical Instrument Digital Interface) is a connectivity standard that musicians use to hook together musical instruments (such as keyboards and synthesizers) and computer equipment.

### 3.10 Keywords

**Bit-Depth:** It describes the number of bits of information recorded for each sample. Bit depth directly corresponds to the resolution of each sample in a set of digital audio data.

**Digital Audio Recording:** It refers to the process of capturing physical waveforms as an electronic signal of 1s and 0s rather than the analogue electro mechanical signals (such as etching in a wax cylinder).

**MP3:** It is a digital audio encoding format that is designed to greatly reduce the amount of data required to represent audio recordings. It uses a lossy data compression that works by reducing accuracy of certain parts of sound that are deemed beyond the auditory resolution ability of most people.

**Sample rate:** It defines the number of samples per second taken from a continuous signal to make a discrete signal. It is measured in hertz. The audio CD uses 44,100 Hz sampling, which means that every second the sound is recorded a total of 44,100 times.

**Notes**

**Wav (or Wave):** Short for Waveform audio format. It is a digital audio encoding format that is considered uncompressed and lossless. TIFF is the counterpart on Mac.

**3.11 Review Questions**

1. Write a short note on audio file formats.
2. What are the various advantages and disadvantages of MIDI?
3. Describe two types of sounds – analogue and digital.
4. Have a discussion on the operations of digital video recordings.
5. How is digital audio different from MIDI?
6. Determine which audio formats are best suited for a multimedia project.
7. Explain sampling rate and bit rate with an example.
8. Describe types of digital audio file formats.
9. Explain multimedia sound systems.
10. Write a short note on the use of microphones in a multimedia presentation.

**Answers: Self Assessment**

- |   |             |
|---|-------------|
| 1. Musical Instrument Digital Interface | 2. Two, one |
| 3. Total Audio Converter                | 4. 1983     |
| 5. Motion Picture Experts Group         | 6. (b)      |
| 7. (d)                                  | 8. (c)      |
| 9. (a)                                  | 10. (c)     |

**3.12 Further Readings**



*Books*

Frederick P. Brooks, Jr., Kenan Professor of Computer Science, *The Mythical Man-Month: Essays in Software Engineering*, University of North Carolina at Chapel Hill.

K. Andleigh and K. Thakkar, *Multimedia System Design*, PHI, PTR.

Steve Rimmer (2000), *Advanced Multimedia Programming*, MHI.

Tay Vaughan, *Multimedia Making it work*, Seventh Edition, Tata McGraw-Hill Education Private Ltd.



*Online links*

<http://nora.lis.uiuc.edu:3030/companion/view?docId=blackwell/9781405103213/9781405103213.xml&doc.view=print&chunk.id=ss1-2-10&toc.depth=1&toc.id=0>

[http://users.mct.open.ac.uk/yr258/papers/Rogers\\_Scaife98.pdf](http://users.mct.open.ac.uk/yr258/papers/Rogers_Scaife98.pdf)

<http://www.icheg.org/icheg-game-history/timeline/>

**Notes**

<http://www.ict.griffith.edu.au/teaching/1611ICT/mm1alectures/111/Writing%20For%20Multimedia%20Great%20Moments%20In%20Multimedia%20History.htm>

[http://www.oralhistory.org/technology/audio\\_basics/](http://www.oralhistory.org/technology/audio_basics/)

## Unit 4: Image

### CONTENTS

Objectives

Introduction

#### 4.1 Categories of Digital Graphics

4.1.1 Bitmaps

4.1.2 Vector Drawings

4.1.3 Meta Graphics

4.1.4 Animated Graphics

#### 4.2 Three Dimensional (3D) Drawing and Rendering

#### 4.3 Natural Light and Colour

#### 4.4 Computerized Colours

4.4.1 How Computers See Colour?

#### 4.5 Colour Palettes

4.5.1 Display Quality

4.5.2 Safety Palette

4.5.3 Dithering

4.5.4 Gamma Correction

4.5.5 Bandwidth Issues

4.5.6 Colour Palette Generator

#### 4.6 Image File Formats

4.6.1 Graphics Interchange Format (GIF)

4.6.2 Portable Network Graphics (PNG)

4.6.3 Joint Photographic Experts Group (JPEG)

#### 4.7 Macintosh Image Format

4.7.1 File Organization

#### 4.8 Windows Imaging File Format (WIM)

4.8.1 WIM File Structure

4.8.2 WIM File Layout

4.8.3 Benefits of Leveraging WIM

4.8.4 Understanding Windows Image Files and Catalog Files

4.8.5 WIMGAPI Tool for Windows Image Deployment

Contd....

## Notes

4.9	Cross-platform Formats
4.9.1	Cross-platform Problems in Current Scenario
4.10	Summary
4.11	Keywords
4.12	Review Questions
4.13	Further Readings

## Objectives

After studying this unit, you will be able to:

- Describe the bitmap images and analyse the vector drawing
- Enumerate 3D drawing and rendering
- Explain natural lights, colours, computerized colours and colour palettes
- Understand the image file formats such as Macintosh image format, windows imaging file format and analyse the cross-platform formats

## Introduction

Still images are vital to multimedia applications. We are a very visual society. With the advent of technology, we have become even more visual. This is because our society is fast-paced and in many circumstances, a picture really is worth a thousand words. One table, chart, graphic, or photograph can illustrate what might take many pages of narrative text to communicate. In the end, the image may still do a better job of creating a lasting impression. In societies such as ours where communicating information quickly is crucial, the importance of graphic elements in multimedia applications cannot be overstated.

In addition, once images are in a digital format, you can digitize images that are currently photographs, slides, or line art. Image-editing software such as Adobe Photoshop can be used to edit and manipulate them even further. Using image-editing software, multimedia developers can combine text and images to create almost any work of art they can imagine. Because still images are so vital to a multimedia project, care and time in creating just the right image is important. When searching for the right image for your multimedia application, you should first create a list description of the images you need for your project. Once you know what you choose to create the images yourself, obtain the images from a provider, or hire a graphic designer to create them for you.

The term “graphics” used in this Unit refers to any type of visual representation displayed on digital systems and screens (computers, phone, TV). Graphics fall into three main categories:

1. Images, for instance, scanned/downloaded photos
2. Computer generated graphics, for instance, logos, interface elements
3. Computer generated images, for instance, graphics that look lifelike

## 4.1 Categories of Digital Graphics

Here you will be working with images and computer generated graphics. You would work with computer generated images in subjects such as 3D animation. These can be further split into four sub-categories:

1. Bitmap
2. Vector
3. Meta
4. Animated

### 4.1.1 Bitmaps

Bitmaps are exactly as their name implies, maps of binary colour information. They store this information in a grid of points, or pixels, which has a fixed width and height, and they can store various ranges of colours according to the image type (see Colour Depth on next page).



*Example:* A bitmap-based image of 1 inch x 1 inch with a 600 dpi resolution would be defined by a grid of 600 x 600 pixels. A bitmap-based image is like a mosaic of pixels with each pixel holding a specific colour value.

As they are a fixed number of pixels wide and high, they are difficult to resize, and have a limited resolution—zooming in produces a blocky, “pixelated” image. At normal resolution, the pixels are too small for the eye to distinguish, and we see smooth and subtle colour transitions.

Figure 4.1: A Bitmap Graphic

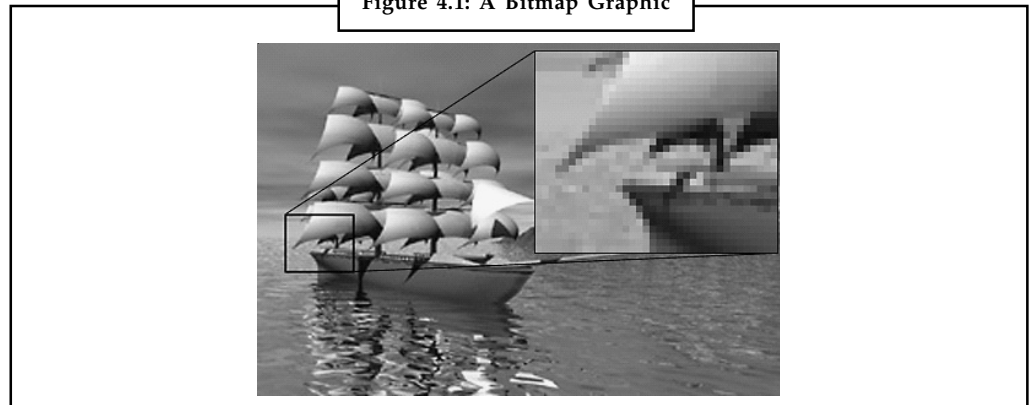

Source: <http://www.ps.missouri.edu/ps2/support/customersupport/preparingJobs/Bitmap01.jpg>

Figure 4.2: Both A and B images show bitmap graphics. A bitmap graphic is made up from discrete shaded pixels, which together display the image.

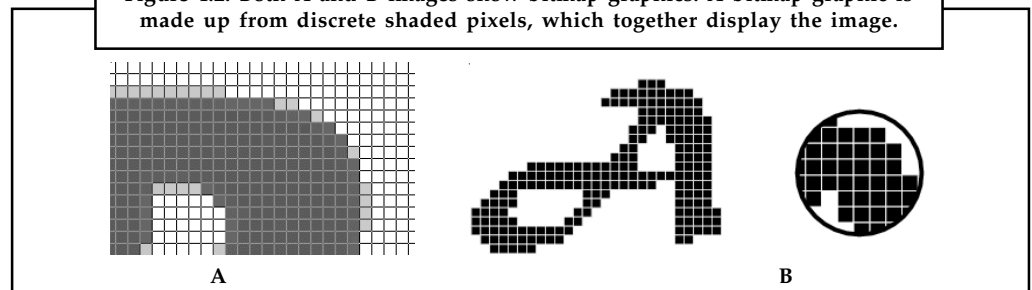

Source: [http://services.exeter.ac.uk/cmit/modules/the\\_internet/figures/bitmap-magnified.gif](http://services.exeter.ac.uk/cmit/modules/the_internet/figures/bitmap-magnified.gif) and [http://4.bp.blogspot.com/-5hvSvkeFdG8/TdsH\\_IC4ydI/AAAAAAAAAnI/KVGMA\\_u\\_7bo/s400/vector-vs-bitmap.png](http://4.bp.blogspot.com/-5hvSvkeFdG8/TdsH_IC4ydI/AAAAAAAAAnI/KVGMA_u_7bo/s400/vector-vs-bitmap.png)

Some common bitmap formats are GIF, JPG or JPEG, TIFF, PNG, PICT, PCX, and BMP. Photo-editors or image-editing graphics software such as Adobe Photoshop and Corel Photo-Paint are designed for creating and editing bitmap graphics.

The web has tended to concentrate on bitmaps as they are easier to create and render on screen. For this reason, we'll take a more detailed look at bitmaps in the next few paragraphs.

### Colour Depth

- Describes the amount of storage per pixel
- Also indicates the number of colours available
- Higher colour depths require greater compression
- See Figure 4.3, "Eight-Bit Colour" and Figure 4.4, "Twenty-Four-Bit Colour (True-Colour)"

When a bitmap image is constructed, the colour of each point or pixel in the image is coded into a numeric value. This value represents the colour of the pixel, its hue and intensity. When the image is displayed on the screen, these values are transformed into intensities of red, green and blue for the electron guns inside the monitor, which then create the picture on the phosphor lining of the picture tube. In fact, the screen itself is mapped out in the computer's memory, stored as a bitmap from which the computer hardware drives the monitor.

These colour values have to be finite numbers, and the range of colours that can be stored is known as the colour depth. The range is described either by the number of colours that can be distinguished, or more commonly by the number of bits used to store the colour value. Thus, a pure black and white image (i.e. no greys) would be described as a 1-bit or 2-colour image, since every pixel is either black (0) or white (1). Common colour depths include 8-bit (256 colours) and 24-bit (16 million colours). It's not usually necessary to use more than 24-bit colour, since the human eye is not able to distinguish that many colours, though broader colour depths may be used for archiving or other high quality work.

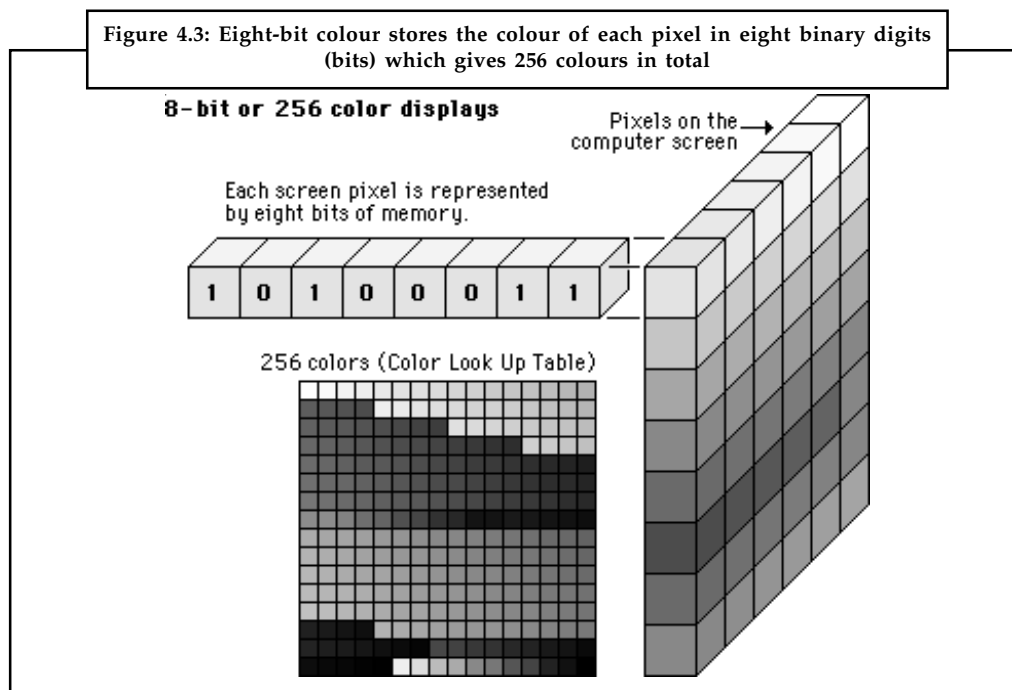

Source: [http://services.exeter.ac.uk/cmit/modules/the\\_internet/figures/eight-bit-colour.gif](http://services.exeter.ac.uk/cmit/modules/the_internet/figures/eight-bit-colour.gif)

Notes

There are a number of interesting attributes of such a colour indexing system. If there are less than 256 colours in the image then this bitmap will be the same quality as a 24 bit bitmap but it can be stored with one third the data. Interesting colouring and animation effects can be achieved by simply modifying the palette, this immediately changes the appearance of the bitmap and with careful design can lead to intentional changes in the visual appearance of the bitmap.

A common operation that reduces the size of large 24 bit bitmaps is to convert them to indexed colour with an optimized palette, that is, a palette which best represents the colours available in the bitmap.

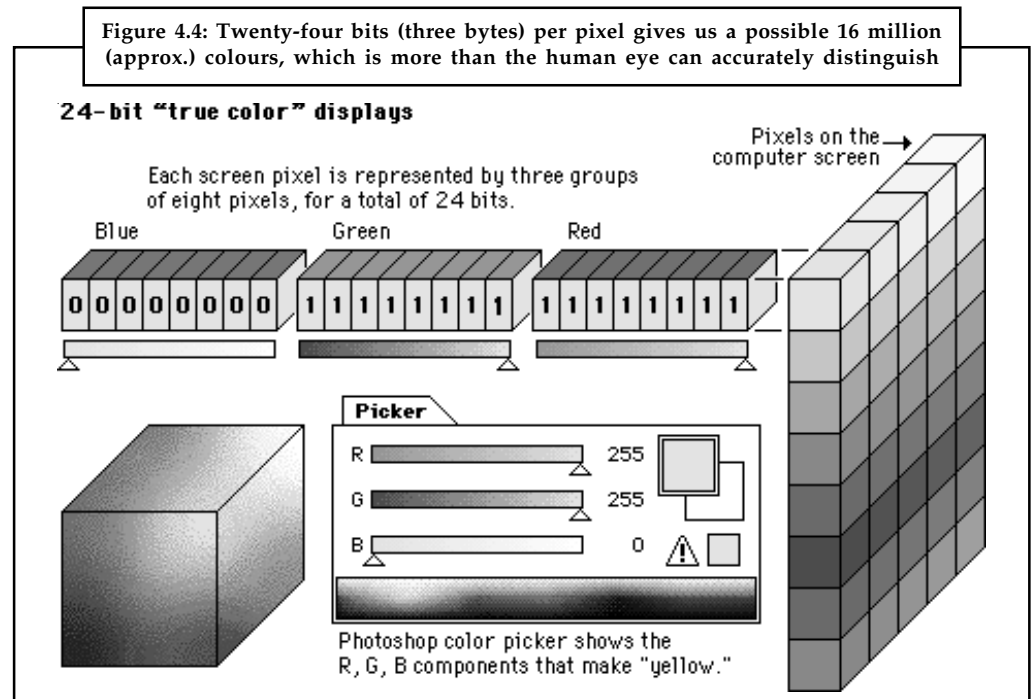

Source: [http://services.exeter.ac.uk/cmit/modules/the\\_internet/figures/twenty-four-bit-colour.gif](http://services.exeter.ac.uk/cmit/modules/the_internet/figures/twenty-four-bit-colour.gif)

**Resolution**

Resolution is a measure of how finely a device displays graphics with pixels. It is used by printers, scanners, monitors (TV, computer), mobile devices and cameras. There are two types/ways of measuring resolution:

The amount of (dpi) dots per inch. Printers and scanners work with higher resolutions than computer monitors. Current desktop printers can support 300dpi+, flatbed scanners from 100-3600dpi+. In comparison computer monitors support 72-130 dpi. This is also known as "Image resolution".

The size of the frame (as in video) and monitor. For instance, the size of video frame used for British Televisions is 768 x 576, whereas American TVs use 640 x 480.



*Did u know?* PPI (Pixels Per Inch) is a term also used to define the resolution for bitmaps.

Bitmap images are resolution-dependent as they contain a fixed number of pixels. As a result, they can lose detail and appear jagged if they are scaled to high magnifications on screen or if they are printed at a lower resolution than they were created for.



Figure 4.5: Example of a Bitmap Image at Different Levels of Magnification

Notes

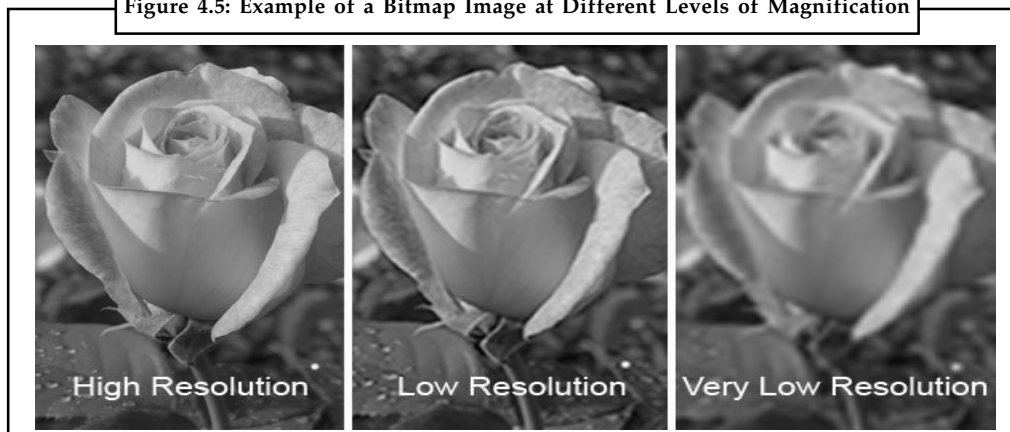

Source: <http://skyhawkstudios.files.wordpress.com/2013/04/image-quality-2.jpg?w=600&h=311>

Bitmap images sometimes require large amounts of storage space, and often need to be compressed to keep file sizes down when used in certain Creative Suite components. For instance, you compress an image file in its original application before you import it into a layout.



*Notes* In Adobe Illustrator, you can create bitmap effects in your artwork using effects and graphic styles.

### Image Resolution Guidelines for Final Output

Bitmap images contain a fixed number of pixels, usually measured in pixels per inch (ppi). An image with a high resolution contains more, and therefore smaller, pixels than an image of the same printed dimensions with a low resolution.



*Example:* A one inch by one inch image with a resolution of 72 ppi contains a total of 5184 pixels (72 pixels wide × 72 pixels high = 5184). The same one inch by one inch image with a resolution of 300 ppi would contain a total of 90,000 pixels.

For imported bitmap images, image resolution is determined by the source file. For bitmap effects, you can specify a custom resolution. To determine the image resolution to use, consider the medium of final distribution for the image. The following guidelines can help you determine your requirements for image resolution:

#### Commercial Printing

Commercial printing requires 150 to 300 ppi (or more) images, depending on the press (dpi) and screen frequency (lpi) you're using; always consult your pre-press service provider before making production decisions. Because commercial printing requires large, high-resolution images, which take more time to display while you're working with them, you may want to use low-resolution versions for layout and then replace them with high-resolution versions at print time.

In Illustrator and InDesign, you can work with low resolution versions by using the Links panel. In InDesign you can choose either Typical or Fast Display from the View > Display Performance menu; in Illustrator you can choose View > Outline. Alternatively, if your service provider supports Open Prepress Interface (OPI), they may provide low-resolution images to you.

Notes

**Desktop Printing**

Desktop printing usually requires images within the range of 72 ppi (for photographs printed on a 300 ppi printer) to 150 ppi (for photographs printed on devices up to 1000 ppi). For line art (1 bit images), make sure that the resolution of your graphics matches the resolution of the printer.

**Web Publishing**

Usually online publishing requires images with pixel dimensions that fit the intended monitor. To leave room for browser window controls or such layout elements as captions the images are usually less than 500 pixels wide and 400 pixels tall. Creating an original image at screen resolution—96 ppi for Windows-based images—lets you see the image as it will likely appear when viewed from a typical web browser. When you're publishing online, the only times you're likely to need resolutions above those ranges are when you want viewers to be able to zoom in for more detail in a PDF document, or when you're producing a document for printing on demand.

**Bitmap Image Compression**

- High colour photographic images need compression
- Lossless compression preserves all picture information
- Lossy compression creates much smaller files
- Be careful when repeatedly editing lossy-format files

Another aspect to consider when choosing an image format is the compression method used to store the image within a reasonable file size. Some formats store the colour information per pixel without using any compression, but with anything other than the smallest files this is impractical (think of a 800 × 600 × 24-bit image, an average screen-sized bitmap, which would be over 1.4 MB), especially when downloaded from the web. Compression allows us to store the same image in a much smaller file, which can be downloaded in a much more reasonable time.

There are two basic compression types – lossless and lossy. Lossless compression stores all the information exactly, without loss of quality or accuracy, a perfect copy. The image recreated on the screen is exactly the same as the image created by the original designer. Lossless compression works particularly well for images with large, solid blocks of colour, which it condenses very effectively.



*Example:* If on a row of pixels there is a line of thirty red pixels, then we can store the colour value for 'red' once, and store the fact that it's repeated thirty times, which would save us around twenty to twenty-five colour-value entries. This type of simple compression can make significant savings with certain types of image.

*Lossy Compression*, on the other hand, has more advanced ways of compressing the image data, though this comes at the cost of precise reproduction. In lossy compression, the program creating the image looks for patterns of detail within the image, and compresses areas of low detail much more highly than areas of high detail. The patterns are converted into mathematical formulae describing the pattern's colours, with more complex formulae being used for more highly detailed regions. This can result in images that are significantly smaller than when encoded using other compression methods, especially with photographic images (see Figure 4.6, "Lossy Compression – High Quality"). The compression is called lossless because these formulae never

recreate the image with total precision; there is always some loss of information when the image is decompressed.

Figure 4.6: Lossy Compression - High Quality



Image saved as JPEG at 90% quality (10% compression, 15kB file size). The image appears sharp and clear, and does not seem to have lost any quality due to the compression, even though the file size has reduced from 75kB uncompressed to 15kB.

Source: [http://services.exeter.ac.uk/cmit/modules/the\\_internet/figures/lossy-90pc-quality.jpg](http://services.exeter.ac.uk/cmit/modules/the_internet/figures/lossy-90pc-quality.jpg)

This is most noticeable when a high compression ratio is used, since the image will become blocky and details will become blurred (see Figure 4.7, “Lossy Compression – Low Quality”). The information loss also becomes apparent if the image is repeatedly saved and reopened; like copying a video-cassette, each time a copy is made more of the quality is irretrievably lost.

Figure 4.7: Lossy Compression - Low Quality



Image saved as JPEG at 10% quality (90% compression, 1.5kB file size). The image is much fuzzier, with artefacts or distortion created by the extreme compression.

Source: [http://services.exeter.ac.uk/cmit/modules/the\\_internet/figures/lossy-10pc-quality.jpg](http://services.exeter.ac.uk/cmit/modules/the_internet/figures/lossy-10pc-quality.jpg)

### Changing Size and Colour Palette for Bitmaps

Use Transform Bitmap to change the size, color depth, and palette of selected cast members. Any change you make to a cast member's color depth or palette affects the cast member itself—not only its appearance on the Stage. You can't undo changes to the color depth and palette. If you want to keep a cast member's original bitmap unchanged but temporarily apply a different palette, use the Member tab in the cast member's Property inspector. To change the size of only the sprite on the Stage, use the Sprite tab in the sprite's Property inspector.

You can also remap images to new palettes with an image-editing program such as Fireworks.

The Transform Bitmap dialog box displays values for the current selection. If you select more than one cast member, a blank value indicates that cast members in the selection have different values. To maintain a cast member's original value, leave that value blank in the dialog box.

Notes

1. Select the bitmap cast members to change.
2. Select Modify > Transform Bitmap.
3. To change the size of the bitmap, do one of the following:  
If multiple cast members are selected, you can resize all the cast members to the dimensions you enter.
  - ❖ Enter new measurements (in pixels) in the Width and Height text boxes.
  - ❖ Enter a scaling percentage in the Scale text box.Select Maintain Proportions to keep the width and height of the selected cast member in proportion. If you change the width, the proportional height is automatically entered in the Height text box. If you use Transform Bitmap to change several cast members at once, be sure to deselect Maintain Proportions. If you don't, all cast members are resized to the values in the Width and Height text boxes.
4. To change the colour depth, select an option from the Colour Depth pop-up menu. For more information about the color depth of bitmap cast members, see Controlling colour.
5. To change the palette, select a palette from the Palette menu and select one of the following remapping options:
  - ❖ *Remap Colours* – it replaces the original colours in the graphic with the most similar solid colors in the new palette. This is the preferred option in most cases.
  - ❖ *Dither* – it blends the colours in the new palette to approximate the original colors in the graphic.

Figure 4.8: 256 greys

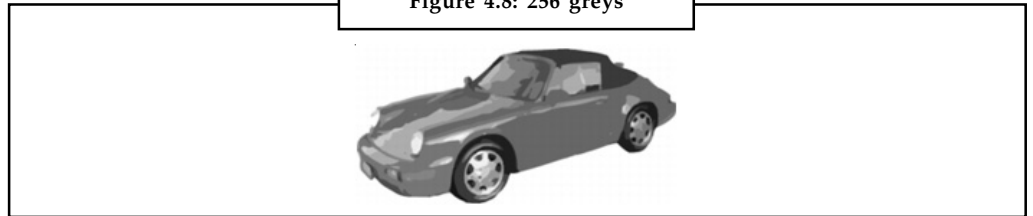

Source: [http://help.adobe.com/en\\_US/Director/11.0/images/256\\_grays.png](http://help.adobe.com/en_US/Director/11.0/images/256_grays.png)

Figure 4.9: Remapped to Closest Colours in Black and White

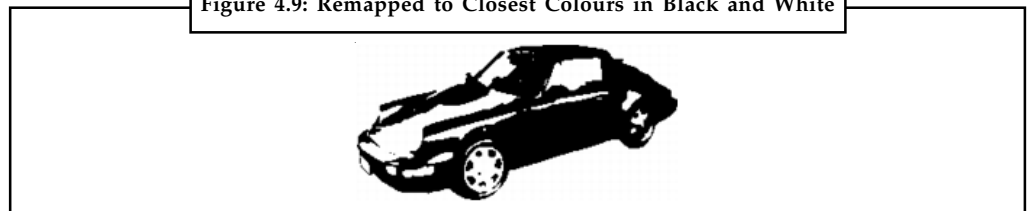

Source: [http://help.adobe.com/en\\_US/Director/11.0/images/256\\_grays.png](http://help.adobe.com/en_US/Director/11.0/images/256_grays.png)

Figure 4.10: Dithered in Black and White

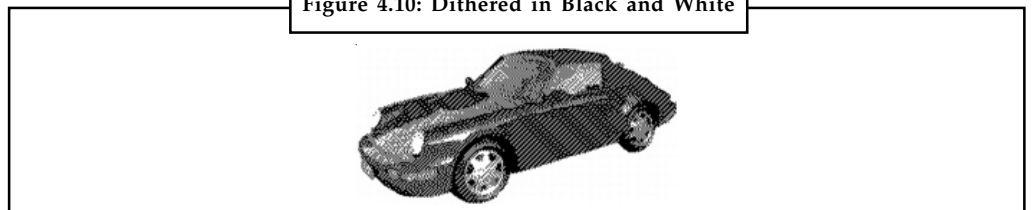

Source: [http://help.adobe.com/en\\_US/Director/11.0/images/256\\_grays.png](http://help.adobe.com/en_US/Director/11.0/images/256_grays.png)

6. Click Transform to execute the changes. The settings you select in the Transform Bitmap dialog box cannot be undone.

Notes



*Task* Select a low colour depth image and convert it into a high colour depth image.

## Bitmap Storage

A bitmap that stores indexes into a colour table is called a palette-indexed bitmap. Some bitmaps have no need for a colour table.



*Example:* If a bitmap uses 24 bits per pixel, that bitmap can store the colours themselves rather than indexes into a colour table. The following illustration shows a bitmap that stores colours directly (24 bits per pixel) rather than using a colour table. The illustration also shows an enlarged view of the corresponding image.

**Figure 4.11:** In the bitmap, FFFFFFFF represents white, FF0000 represents red, 00FF00 represents green, and 0000FF represents blue.

```

0000FF 0000FF 0000FF 0000FF 0000FF 0000FF 0000FF 0000FF
00FF00 FF0000 FFFFFFFF FF0000 FFFFFFFF FF0000 FFFFFFFF 00FF00
00FF00 FFFFFFFF FF0000 FFFFFFFF FF0000 FFFFFFFF FF0000 00FF00
00FF00 FF0000 FFFFFFFF FF0000 FFFFFFFF FF0000 FFFFFFFF 00FF00
00FF00 FFFFFFFF FF0000 FFFFFFFF FF0000 FFFFFFFF FF0000 00FF00
00FF00 FF0000 FFFFFFFF FF0000 FFFFFFFF FF0000 FFFFFFFF 00FF00
00FF00 FFFFFFFF FF0000 FFFFFFFF FF0000 FFFFFFFF FF0000 00FF00
0000FF 0000FF 0000FF 0000FF 0000FF 0000FF 0000FF 0000FF

```



Source: <http://i.msdn.microsoft.com/dynimg/IC153188.gif>

## Graphics File Formats

There are many standard formats for saving bitmaps in files. Windows GDI+ supports the graphics file formats described in the following paragraphs.

### Bitmap (BMP)

BMP is a standard format used by Windows to store device-independent and application-independent images. The number of bits per pixel (1, 4, 8, 15, 24, 32, or 64) for a given BMP file is specified in a file header. BMP files with 24 bits per pixel are common.

### Graphics Interchange Format (GIF)

GIF is a common format for images that appear on webpages. GIFs work well for line drawings, pictures with blocks of solid color, and pictures with sharp boundaries between colors. GIFs are compressed, but no information is lost in the compression process; a decompressed image is exactly the same as the original. One color in a GIF can be designated as transparent, so that the image will have the background color of any Web page that displays it. A sequence of GIF images can be stored in a single file to form an animated GIF. GIFs store at most 8 bits per pixel, so they are limited to 256 colors.

Notes

**Joint Photographic Experts Group (JPEG)**

JPEG is a compression scheme that works well for natural scenes, such as scanned photographs. Some information is lost in the compression process, but often the loss is imperceptible to the human eye. Colour JPEG images store 24 bits per pixel, so they are capable of displaying more than 16 million colors. There is also a grey scale JPEG format that stores 8 bits per pixel. JPEGs do not support transparency or animation.

The level of compression in JPEG images is configurable, but higher compression levels (smaller files) result in more loss of information. A 20:1 compression ratio often produces an image that the human eye finds difficult to distinguish from the original. The Figure 4.12 shows a BMP image and two JPEG images that were compressed from that BMP image. The first JPEG has a compression ratio of 4:1 and the second JPEG has a compression ratio of about 8:1.

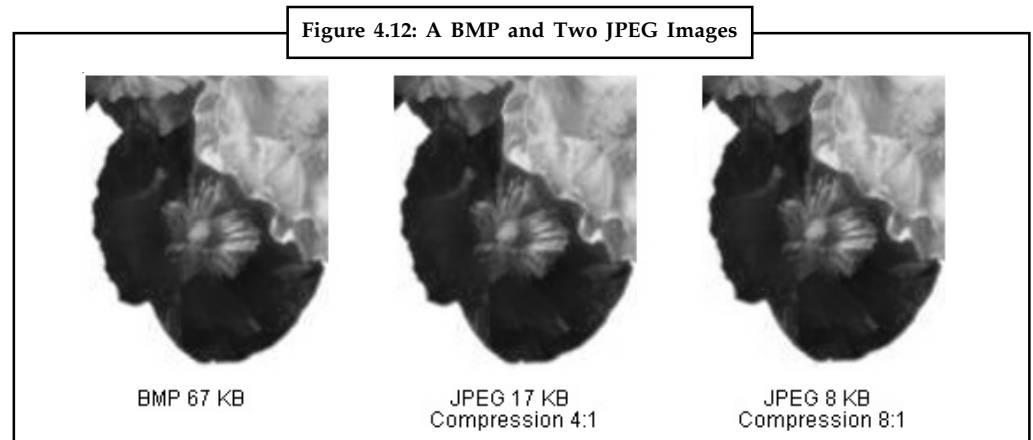

Source: <http://i.msdn.microsoft.com/dynimg/IC153188.gif>

JPEG compression does not work well for line drawings, blocks of solid color, and sharp boundaries. The Figure 4.13 shows a BMP along with two JPEGs and a GIF. The JPEGs and the GIF were compressed from the BMP. The compression ratio is 4:1 for the GIF, 4:1 for the smaller JPEG, and 8:3 for the larger JPEG. Note that the GIF maintains the sharp boundaries along the lines, but the JPEGs tends to blur the boundaries.

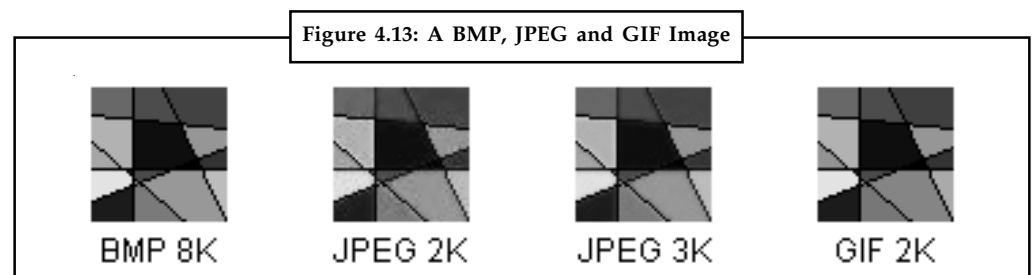

Source: <http://i.msdn.microsoft.com/dynimg/IC153188.gif>

JPEG is a compression scheme, not a file format. JPEG File Interchange Format (JFIF) is a file format commonly used for storing and transferring images that have been compressed according to the JPEG scheme. JFIF files displayed by Web browsers use the .jpg extension.

**Exchangeable Image File (Exif)**

Exif is a file format used for photographs captured by digital cameras. An Exif file contains an image that is compressed according to the JPEG specification. An Exif file also contains information

about the photograph (date taken, shutter speed, exposure time, and so on) and information about the camera (manufacturer, model, and so on).

Notes

### Portable Network Graphics (PNG)

The PNG format retains many of the advantages of the GIF format but also provides capabilities beyond those of GIF. Like GIF files, PNG files are compressed with no loss of information. PNG files can store colors with 8, 24, or 48 bits per pixel and gray scales with 1, 2, 4, 8, or 16 bits per pixel. In contrast, GIF files can use only 1, 2, 4, or 8 bits per pixel. A PNG file can also store an alpha value for each pixel, which specifies the degree to which the color of that pixel is blended with the background colour.



*Notes* PNG improves on GIF in its ability to progressively display an image; that is, to display better and better approximations of the image as it arrives over a network connection. PNG files can contain gamma correction and color correction information so that the images can be accurately rendered on a variety of display devices.

### Tag Image File Format (TIFF)

TIFF is a flexible and extendable format that is supported by a wide variety of platforms and image-processing applications. TIFF files can store images with an arbitrary number of bits per pixel and can employ a variety of compression algorithms. Several images can be stored in a single, multiple-page TIFF file. Information related to the image (scanner make, host computer, type of compression, orientation, samples per pixel, and so on) can be stored in the file and arranged through the use of tags. The TIFF format can be extended as needed by the approval and addition of new tags.

#### 4.1.2 Vector Drawings

Vector Drawings are completely computer generated. They are otherwise known as object-oriented graphics as they consist of objects such as shapes. Vectors are used to create graphics such as interface elements (banners, buttons) text, line art and detailed drawings (plans, maps). Essentially they are computer generated drawings. Effects can be added to vector graphics to add realism, however, they need to be converted to bitmaps in order to do this.

Vectors don't consist of pixels. Instead, they are made up of co-ordinates, shapes, line, and colour data. Therefore they aren't resolution dependant. It is for this reason that vector graphics can be scaled without losing their quality. Vectors are also easier to edit. In comparison to bitmaps, vectors have nice clean edges.

The following extract from the Adobe site gives a further definition of Vector graphics:

“You can freely move or modify vector graphics without losing detail or clarity, because they are resolution-independent—they maintain crisp edges when resized, printed to a PostScript printer, saved in a PDF file, or imported into a vector-based graphics application. As a result, vector graphics are the best choice for artwork, such as logos, that will be used at various sizes and in various output media.”

Vector file formats create smaller file sizes than bitmaps generally. Vectors still aren't well supported on in the world wide web. To include a vector in a website it is still best to rasterize it, for instance, convert it to a bitmap. This can however, result in the edges of the vector graphic loosing definition and become pixelated.

Notes

### Difference between Bitmap and Vector Images

Unlike bitmaps, vector images are not based on pixel patterns, but instead use mathematical formulas to draw lines and curves that can be combined to create an image from geometric objects such as circles and polygons. Vector images are edited by manipulating the lines and curves that make up the image using a program such as Adobe Illustrator.

Vector images have some important advantages over bitmap images. Vector images tend to be smaller than bitmap images. That's because a bitmap image has to store colour information for each individual pixel that forms the image. A vector image just has to store the mathematical formulas that make up the image, which take up less space.

Vector images are also more scalable than bitmap images. When a bitmap image is scaled up you begin to see the individual pixels that make up the image. This is most noticeable in the edges of the image. There are ways of making these jagged edges less noticeable but this often results in making the image blurry as well. When a vector image is scaled up, the image is redrawn using the mathematical formula. The resulting image is just as smooth as the original.

Unfortunately, vector formats are not well supported on the web. The two most popular image formats used on the Web, GIF and JPEG are bitmap formats. Most vector images must first be converted into bitmaps images (or rasterized) before they can be used on the Web. An exception is the SWF format used to create animations using Macromedia's Flash animation software.

Bitmap formats are best for images that need to have a wide range of colour gradations, such as most photographs. Vector formats, on the other hand, are better for images that consist of a few areas of solid colour.



*Example:* Images that are well suited for the vector format include logos and type.

### Bitmap or Vector Graphic?

When deciding whether an image should be a bitmap or vector graphic, you should ask yourself the following questions:

- Does the image need to be resized?
- Does the image need to be drawn to scale?
- Do you need the image to look real?
- Do you have any restrictions on the file size?



*Notes* Note that it is possible for an image to use a combination of vector and bitmap elements.

### 4.1.3 Meta Graphics

Meta graphics can be termed as *hybrid* graphics as they are a combination of bitmap and vector graphics. They aren't as widely used as bitmaps and vectors, and aren't as widely supported. An example of a meta graphic would be a map consisting of a photo showing an aerial view of a town, where the landmarks are highlighted using vector text and graphics, eg arrows.



### 4.1.4 Animated Graphics

Notes

Animated graphics are 'moving graphics' that consist of at least more than one graphic. Vector graphics are mainly the basis of animations. Think of cartoons such as the Simpsons and Family Guy. Effects generated by bitmaps can be added and bitmaps themselves can also be animated. The illusion of movement is created by playing a series of graphics at a certain speed. Too slow, and it will look like a number of static graphics to us. Too fast and we won't be able to make out the graphics at all, they'll just look like a blur. Animation started back in the mid 1800s. Early animators experimented with the speed of playback of their drawings to determine the correct setting to create the illusion of movement. Early filmmakers also experimented with this. The term applied to the playback setting is known as *frame rate*. The frame rate is measured/determined by the amount of *frames per second* (fps) that are displayed. Each frame consists of a change in the image. Early animators and filmmakers found that when images were played back at anything below 12 fps you could see the individual static images, which also resulted in the movement being jerky. The accepted frame rates used today are:

- 12-24fps for animations used in multimedia. 12fps is recommended for web based animations
- 24fps for TV in UK
- 30fps for TV in USA
- 25fps for film

In computer based applications, the higher the frame rate (more fps) = larger file sizes. That's why lower frame rates are recommended.

### Self Assessment

Choose the correct option to answer the following:

1. What does PNG stand for?
 

(a) Portable New Graphic	(b) Picture Network Goal
(c) Portable Network Graphic	(d) None of these
2. What is a JPEG?
 

(a) File format	(b) Compression scheme
(c) Storage device	(d) All of these
3. .... blends the colours in the new palette to approximate the original colors in the graphic.
 

(a) Scale text box	(b) Remap Colours
(c) Lossy Compression	(d) Dither
4. Bitmap images are resolution-dependent as they contain a fixed number of .....
 

(a) Pixels	(b) Bits
(c) Colours	(d) (a) and (b)
5. What is resolution for bitmaps called?
 

(a) Exchangeable Image File (Exif)	(b) Graphics Interchange Format (GIF)
(c) Pixels Per Inch (PPI)	(d) Pixel Bitmap Resolution (PBR)

## 4.2 Three Dimensional (3D) Drawing and Rendering

3 Dimensional refers to objects that are rendered visually on paper, film or on screen in three planes representing width, height and depth (X, Y and Z). In the computer, a 2D drawing program can be used to illustrate a 3D object; however, in order to interactively rotate an object in all axes, it must be created as a 3D drawing in a 3D drawing program. The 3D object that a user creates is called a model and it can be simple as well as complex.

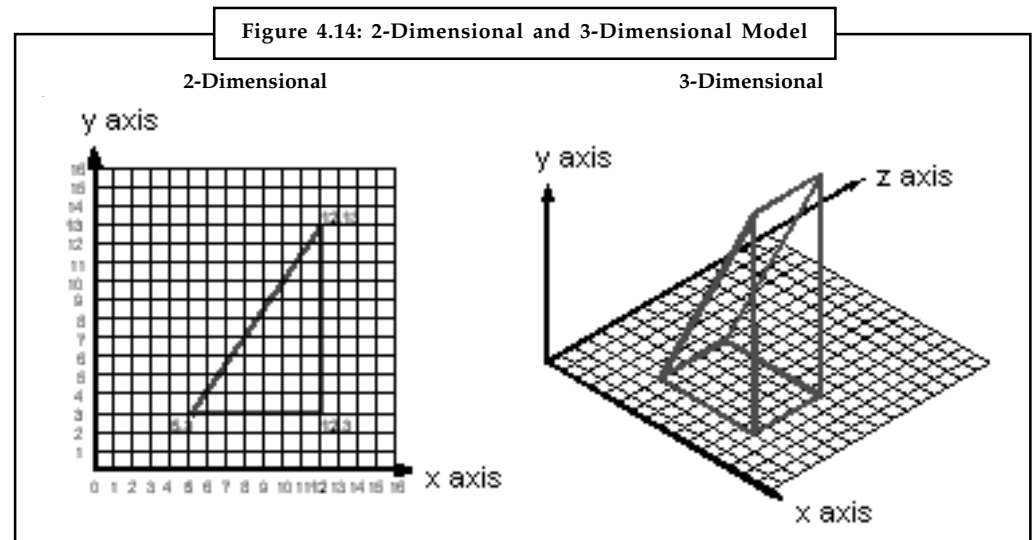

Rendering is the process of generating an image from a model (or models in what collectively could be called a scene file), by means of computer programs. A scene file contains objects in a strictly defined language or data structure; it would contain geometry, viewpoint, texture, lighting, and shading information as a description of the virtual scene. The data contained in the scene file is then passed to a rendering program to be processed and output to a digital image or raster graphics image file. The term “rendering” may be by analogy with an “artist’s rendering” of a scene.

Though the technical details of rendering methods vary, the general challenges to overcome in producing a 2D image from a 3D representation stored in a scene file are outlined as the graphics pipeline along a rendering device, such as a GPU. A GPU is a purpose-built device able to assist a CPU in performing complex rendering calculations. If a scene is to look relatively realistic and predictable under virtual lighting, the rendering software should solve the rendering equation. The rendering equation does not account for all lighting phenomena, but is a general lighting model for computer-generated imagery. Rendering is also used to describe the process of calculating effects in a video editing file to produce final video output.

Rendering is one of the major sub-topics of 3D computer graphics, and in practice always connected to the others. In the graphics pipeline, it is the last major step, giving the final appearance to the models and animation. With the increasing sophistication of computer graphics since the 1970s, it has become a more distinct subject.

Rendering has uses in architecture, video games, simulators, movie or TV visual effects, and design visualization, each employing a different balance of features and techniques. As a product, a wide variety of renderers are available. Some are integrated into larger modelling and animation packages, some are stand-alone, some are free open-source projects. On the inside, a renderer is a carefully engineered program, based on a selective mixture of disciplines related to: light physics, visual perception, and mathematics and software development.

In the case of 3D graphics, rendering may be done slowly, as in pre-rendering, or in real time. Pre-rendering is a computationally intensive process that is typically used for movie creation, while real-time rendering is often done for 3D video games which rely on the use of graphics cards with 3D hardware accelerators.

A rendered image can be understood in terms of a number of visible features. Rendering research and development has been largely motivated by finding ways to simulate these efficiently. Some relate directly to particular algorithms and techniques, while others are produced together.

- **Bump-mapping:** A method of simulating small-scale bumpiness on surfaces
- **Caustics (a form of indirect illumination):** Reflection of light off a shiny object, or focusing of light through a transparent object, to produce bright highlights on another object
- **Depth of field:** Objects appear blurry or out of focus when too far in front of or behind the object in focus
- **Diffraction:** Bending, spreading and interference of light passing by an object or aperture that disrupts the ray
- **Fogging/participating medium:** How light dims when passing through non-clear atmosphere or air
- **Indirect illumination:** Surfaces illuminated by light reflected off other surfaces, rather than directly from a light source (also known as global illumination)
- **Motion blur:** Objects appear blurry due to high-speed motion, or the motion of the camera
- **Non-photorealistic rendering:** Rendering of scenes in an artistic style, intended to look like a painting or drawing
- **Reflection:** Mirror-like or highly glossy reflection
- **Refraction:** Bending of light associated with transparency
- **Shading:** How the colour and brightness of a surface varies with lighting
- **Shadows:** The effect of obstructing light
- **Soft shadows:** Varying darkness caused by partially obscured light sources
- **Texture-mapping:** A method of applying detail to surfaces
- **Translucency:** Highly scattered transmission of light through solid objects
- **Transparency (optics), transparency (graphic) or opacity:** Sharp transmission of light through solid objects

Many rendering algorithms have been researched, and software used for rendering may employ a number of different techniques to obtain a final image. Tracing every particle of light in a scene is about completely impractical and would take a stupendous amount of time. Even tracing a portion large enough to produce an image takes an inordinate amount of time if the sampling is not intelligently restricted.

Therefore, four loose families of more-efficient light transport modelling techniques have emerged: rasterization, including scanline rendering, geometrically projects objects in the scene to an image plane, without advanced optical effects; ray casting considers the scene as observed from a specific point-of-view, calculating the observed image based only on geometry and very basic optical laws of reflection intensity, and perhaps using Monte Carlo techniques to reduce

Notes

artefacts; and ray tracing is similar to ray casting, but employs more advanced optical simulation, and usually uses Monte Carlo techniques to obtain more realistic results at a speed that is often orders of magnitude slower. The fourth type of light transport technique, radiosity is not usually implemented as a rendering technique, but instead calculates the passage of light as it leaves the light source and illuminates surfaces. These surfaces are usually rendered to the display using one of the other three techniques.

### 4.3 Natural Light and Colour

Figure 4.15: Images in Different Colours

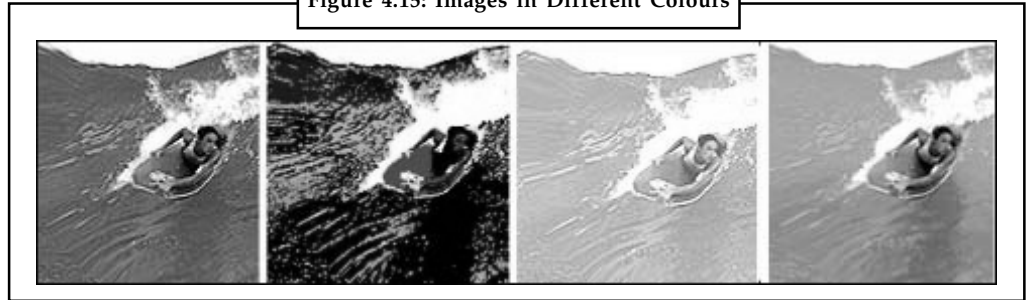

Source: <http://www.colormatters.com/images/images1/zacgam.jpg>

These images represent a range of what any given image may look like to someone viewing this web page today. Therefore, an image that looks good on one computer might look completely different on another. The image at the far left is true to the real colours, the second one from the left represents a very limited colour palette (due to the computer's colour capabilities or the wrong file format), the third from the left is a much lighter version of the first one, and the last image on the right represents a very bad colour distortion caused by a very old monitor.

#### Does True Colour Matter?

Consider this: If you visit a clothing store on the Web and see a blue shirt, you are out of luck if you think that the shirt is really that shade of blue. Also, if you're visiting a museum on the Web to view Matisse's paintings, or researching skin diseases, or analysing a satellite weather photo, you may not be seeing the correct colours and you may be getting incorrect information.

#### How Monitors Work

A colour monitor for a desktop computer is also called a *CRT* or *Cathode Ray Tube*. They operate by transmitting light, or cathode rays, from light guns at the back of the monitor through a phosphor screen, thus creating an image on the screen. Laptop screens, called *LCD*, or *Liquid Crystal Diode* screens, operate by having little circuits called diodes that can be set to selectively allow colour to show through, sort of like shutters.

**Pixel:** short for picture element, the little glowing spots on a computer screen that make up the display.

Both types of screens organize the image into a grid of pixels. Pixel is short for picture element. Each pixel is comprised of three different colours working in combination to create all colours the screen can manage. This process of mixing to create colours is called the additive colour model. The primary colours for the additive model (the colours that are used to make up all other colours) are Red, Green, and Blue. Thus colour CRTs and LCDs are also sometimes called RGB monitors.

Figure 4.16: Primary Colours

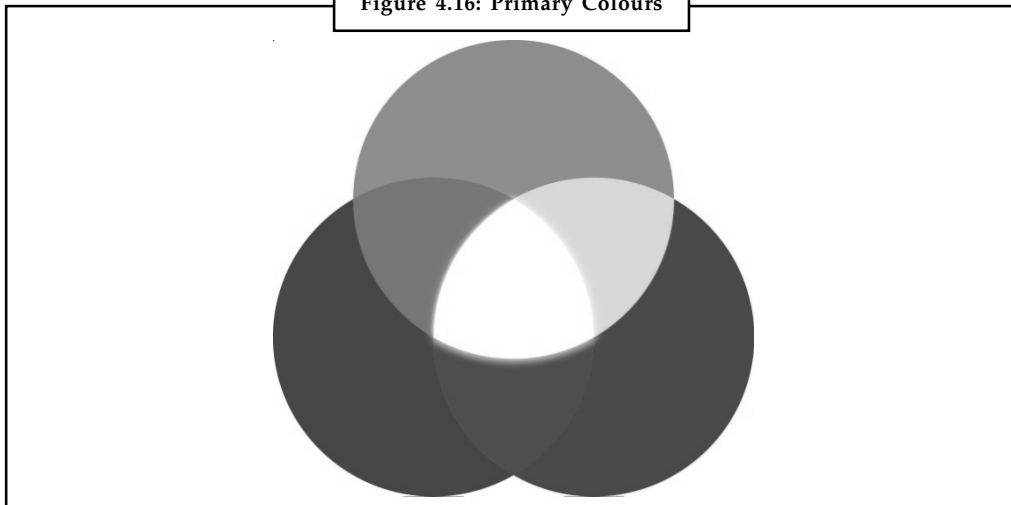

Source: [http://www.primarycoloursconsulting.co.uk/primarycoloursconsulting-co-uk/\\_img/Primary\\_Colours\\_Consulting\\_No\\_Type.jpg](http://www.primarycoloursconsulting.co.uk/primarycoloursconsulting-co-uk/_img/Primary_Colours_Consulting_No_Type.jpg)







### How Computers Identify Colours

Computers identify colours based on how much of each of the three primary colours is used. This value can be represented as three hexadecimal numbers between 00 and FF, or three decimal numbers between 0 and 255.

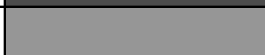
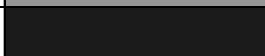
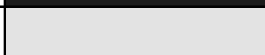
For the purposes of HTML, these numbers have to be specified as hexadecimal numbers.

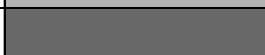
The first number refers to the amount of red, the second to the amount of green, and the third to the amount of blue. If everything is set at 100 per cent you get white. If everything is set to 0 per cent you have black. You can also use colour names for common colours, but it is a toss-up between colour names which self-document and colour values which are better for cross-platform support. Sample colour values are as follows:

Table 4.1: Showing Colour Name, Colour Value and Colour Swatch

Colour Name	Colour Value	Colour Swatch
Red	#FF0000	
Lime (Green)	#00FF00	
Blue	#0000FF	
Yellow	#FFFF00	
Aqua	#00FFFF	
Fuschia	#FF00FF	
White	#FFFFFF	
Black	#000000	
Gray	#808080	

Contd....

Notes

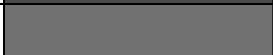
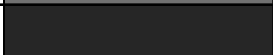
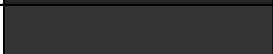
(True) Green	#008000	
Olive	#808000	
Maroon	#800000	
Purple	#800080	

**Video Memory**

In order to display an image, a computer, or the video card of the computer, needs to allocate memory to display the image. A monochrome monitor only needs one bit per pixel. A grey scale monitor (one which can handle sixteen shades of grey, from white to black), needs four bits per pixel. A 256 colour monitor needs eight bits per pixel. True Colour monitors need 24 bits, or one byte each for red, green and blue.

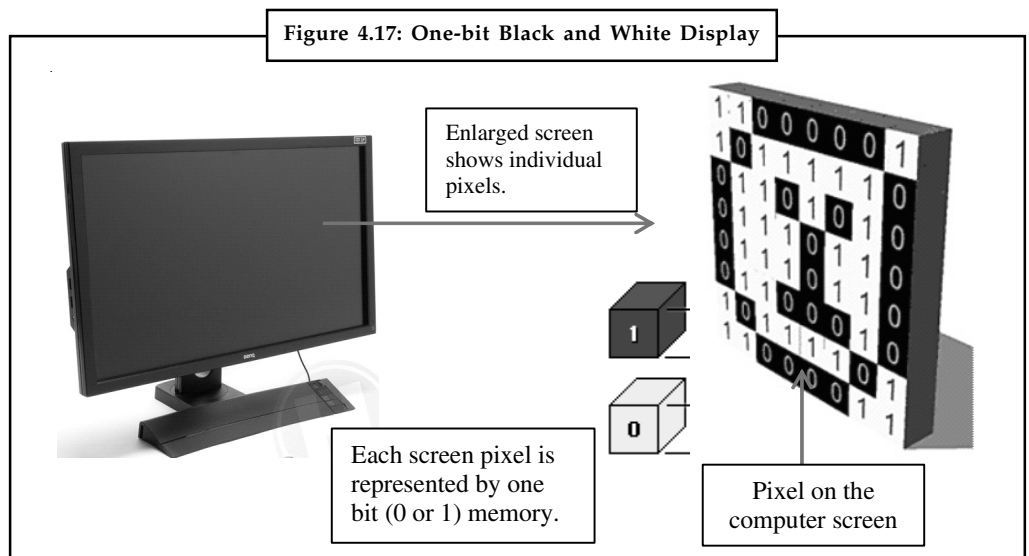

A True Colour monitor with a 800 pixel by 600 pixel screen size would need two megabytes of memory for the monitor. To have a 1024 pixel by 768 pixel screen resolution and true colour usually requires four megabytes of video memory. Compare that to 38 kilobytes for an old monochrome monitor, and actually less because they were text only.

**4.4 Computerized Colours**

Image that looks good on one computer might look completely different on another. For instance, if you visit a clothing store on the Web and see a blue shirt, you are out of luck if you think that the shirt is really that shade of blue. Also, if you are visiting a museum on the Web to view Matisse's paintings, or researching skin diseases, or analysing a satellite weather photo, you may not be seeing the correct colours and you may be getting incorrect information.

**4.4.1 How Computers See Colour?**

The following components work together to create colour on your computer:

- The computer hardware on the motherboard helps in detecting colours.

- Graphic cards or video cards installed on computers help to see better colours and more colours.
- Factors such as old computers and computers with fake or unoriginal hardware and software parts may show colour distortions.
- Anti-glare screen also lower a monitor's efficiency of displaying colours. Colours will appear darker than the actual colour and you may see a grey haze over the whole monitor screen.
- Web browsers such as Chrome, Firefox, Explorer, etc., deliver the collared graphics to your computer. Presently, most Web browsers support graphic file formats that contain essential information about colour (such as PNG).



*Caution* If you have a good video card, good operating system software, and good application software, a bad monitor can still create inaccurate colours. Even if you have a fantastic monitor, the other components can still create bad colours.

## 4.5 Colour Palettes

Colour palette is a subset of all possible colours a monitor can display that is being used to display the current document. In response to these monitor dynamics, Web images tend to be either 8-bit, 256 colour images or 24-bit, true- colour images. The reason for the term true colour is that each monitor colour only has 256 possible settings, so if you use 24-bits, you get every possible colour a monitor can display, somewhere in the neighbourhood of 16 million. The colours used in an 8-bit image are stored in what are called a palette. No 8-bit colour palette can have more than 256 colours, although it is possible to have multiple images, each with a different palette, where the sum total of all the images is more than 256 colours. In such a case, if the monitor only supports 256 colours, some of the images will look odd.

24-bit colour also uses palettes, except that it uses a separate palette for each of the three primary colours, storing the image as three separate layers, one for each colour.

There is also a new colour standard out called 32-bit colour. 32-bit colour has the same colour arrangement as 24-bit colour except that it has one extra byte used to represent the opacity of that pixel. This extra byte is referred to as an alpha, as in alpha transparency. (Photoshop uses the term channels instead.) With alpha transparency, a pixel can not only have 16 million different possible colours, but can have 256 levels of transparency, from totally opaque to totally transparent. We will discuss this a little more when we talk about PNG files.

### 4.5.1 Display Quality

Go to main → graphics → monitors → display quality

These tutorials are about using graphics in Web design. As well as looking at how monitors work, it is useful to understand some constraints and issues that surround graphics on the Web. Here are some caveats having to do with maintaining image quality and the quality of the user experience on the Web.

#### Interactive Palette Tools

We developed the following set of IPTs to address real-world needs. This collection of tools will help designers choose and use colours effectively. They enhance the process of working with

Notes

colour and help users feel more confident that they have explored the possibilities thoughtfully instead of making uninformed guesses.

**Palette Browser**

The IPTs are coordinated through a palette browser (see Figure 4.18) that displays named palettes. In our implementation, a drop-down arrow lets the user hide or show each associated palette. Large swatch sets are displayed on multiple lines.

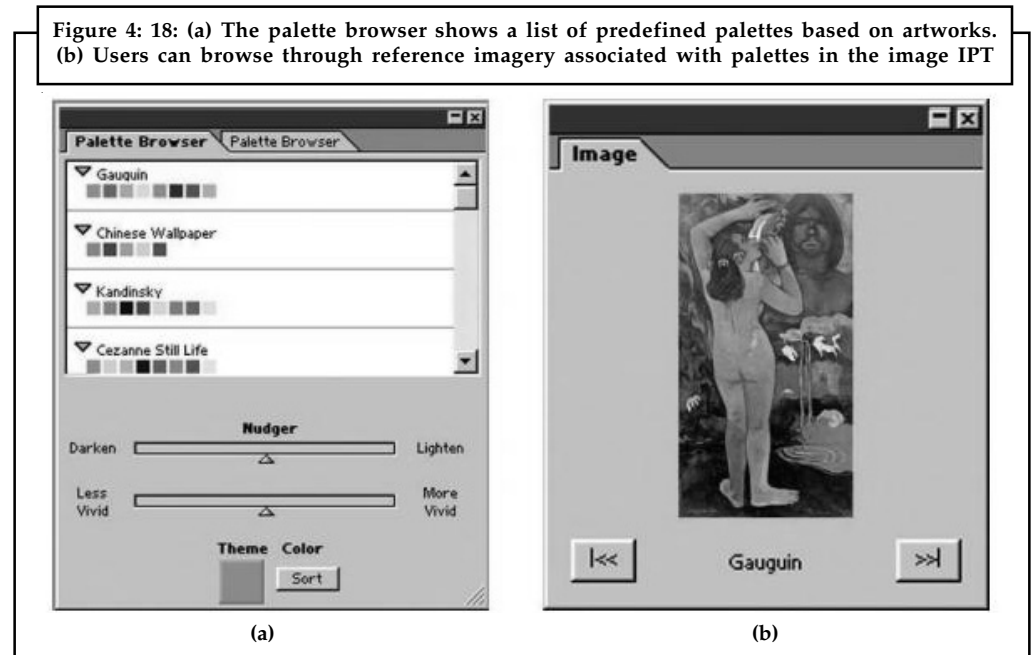

Source: [http://cs.brown.edu/~bjm/meier\\_ipt.pdf](http://cs.brown.edu/~bjm/meier_ipt.pdf)

Survey respondents indicated using palette books (such as Walch and Hope2) to find colour sets without having to create them from scratch. The palette browser isn't a new idea, but existing versions are often tied to a particular task such as creating presentation slides. We enhanced our version with the nudge feature, palette sorting by theme colour, and corresponding reference imagery available in the image and composition tools.

With the nudger, users can modify all colours in a palette simultaneously, making them lighter or darker, or more or less saturated. We make these calculations in the hue-saturation-brightness (HSB) colour space.

A palette displays swatches in the order in which the user defines them, unless the user chooses to sort the swatches by a user-selected theme colour. In the latter case, the closest match the theme colour displays first, followed by the other colours in ascending hue order.

Our browser shares a problem common with many grid-based representations in that it displays swatches at a constant size, out of context, and against a constant background—all of which can mislead users. We envision the browser as a way to quickly find an approximate palette that users can manipulate in another IPT that is free of these limitations.

**Image and Composition Tools**

The image IPT displays an image that uses a palette in the palette browser. Images are typically of artworks, natural objects, or photographs. Users can search separately in the image IPT to bring up related browser palettes.



## Notes

Many survey respondents mentioned using reference imagery as a starting point for choosing colours because a composition provides more information about colour use than a palette displayed as a swatch grid. In an image, users can view how colours appear in different size areas, quantities, and juxtapositions.

The composition IPT takes this concept further by providing an editable image, which allows experimentation with relative sizes of colour fields and their locations in a scratch area. Many art instruction books suggest that designers create colour studies or thumbnails to quickly experiment with colour effects. Survey respondents mentioned making studies using both computers and traditional media, but they complained about the overhead required to create a new document or the problems associated with translating colours between media. Our tool provides an easy and quick way to experiment without the burden of this overhead.

**Figure 4.19: In the composition IPT, users experiment with scale and relative location of coloured fields. (a) We abstracted the size and location of rectangles from a Gauguin painting. These rectangles are movable and scalable. (b) Users can also browse targeted design ideas.**

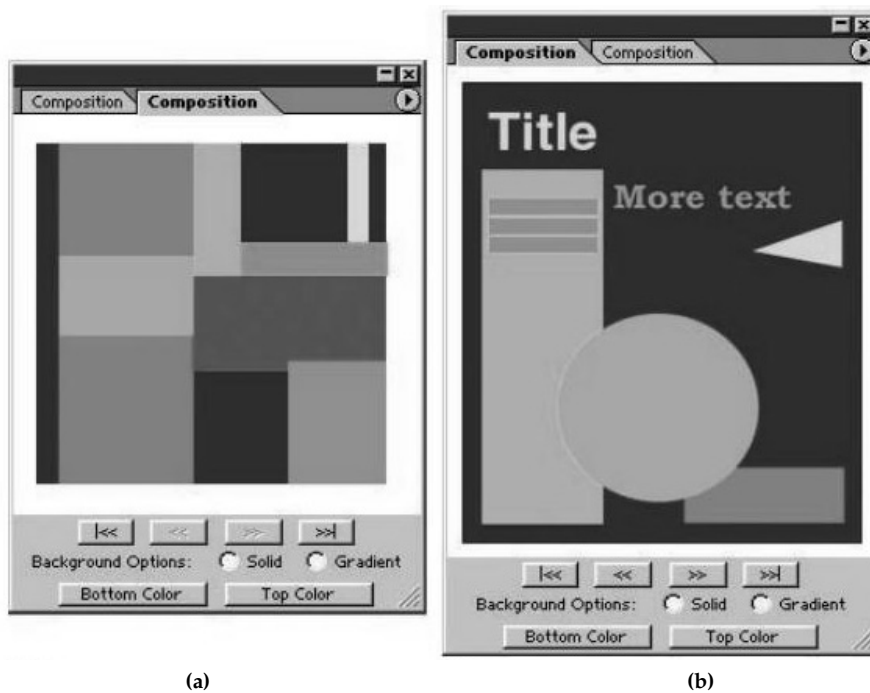

Source: [http://cs.brown.edu/~bjm/meier\\_ipt.pdf](http://cs.brown.edu/~bjm/meier_ipt.pdf)

The tool provides compositions of rectangles abstracted from the reference imagery available in the image IPT. Figure 4.19 a shows an abstracted colour composition for a Gauguin painting. Users can move the shapes by clicking and dragging them. Rolling over a rectangle brings up handles at the corners and midpoints for scaling; making the handles otherwise invisible is important so that they don't visually clutter the composition. Selecting an object brings up a colour picker for modifying the colour.

To provide perceptual context, users can change and display background colours as a solid or gradient.

We present designs of specific types of art and graphic work, such as the poster design in Figure 4.19 (b). Using arrows below the image, a designer can rapidly scroll through compositions associated with different palettes (with the outer arrows) or through different function-targeted

**Notes**

compositions created with one palette (with the inner arrows). Some survey respondents discussed the difficulty of translating a predefined palette to an actual composition. This tool helps bridge that gap, eliminating tedious trial and error.

Choosing a drawing order for the rectangles was an implementation issue with the composition IPT. We experimented with drawing the selected object on top. However, without a method for putting one object under another-which would have complicated the simple interface-the user couldn't change the background object's colour without obscuring the other rectangles. We settled on a fixed drawing order, which works for most quick experiments.

At this point, the targeted designs aren't editable, which might be a future improvement. Also, it could be helpful to assign different colours from the same palette to the various elements of these designs because a particular palette can be used in many ways. We also considered providing a way to assign colours randomly or to rotate through the palette. However, we chose to offer only predetermined assignments that use colour effectively, which might not be the case with random assignments.

**4.5.2 Safety Palette**

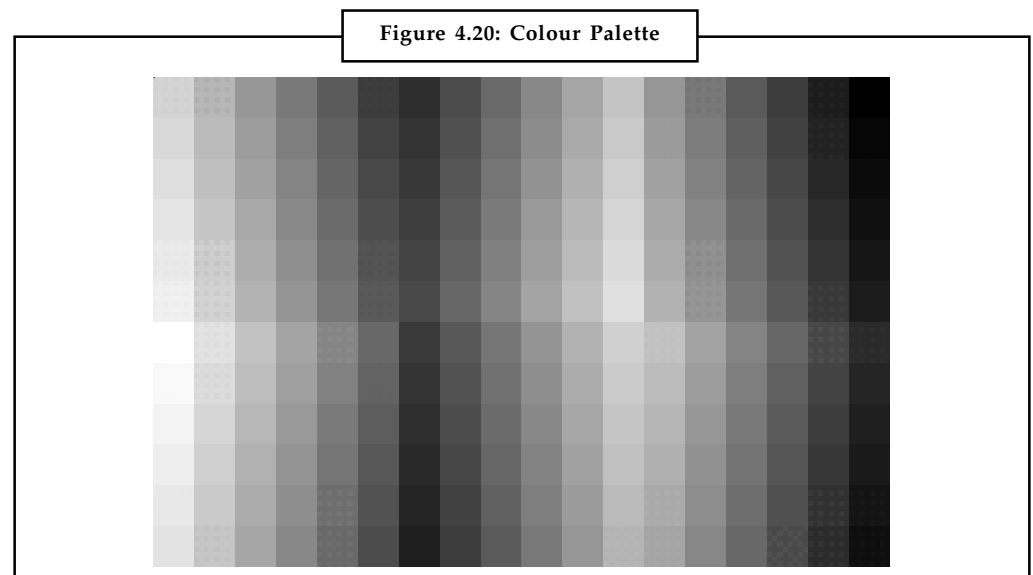

Source: <http://www.colormatters.com/web-safe-color-palette>

In order to avoid problems with older monitors it is recommended that you use what are called "browser safe" colours. This is an 8-bit, 216 colour palette. The other 40 colours are reserved for use by the operating system. If you are pretty sure you users are all using newer monitors, then you don't need to worry about the safety palette, but you still need to know what it is.

These browser safe colours are supported on both Macintosh and Windows platforms, as well as all the other major operating systems coming out for PCs these days. Obviously, with a photograph, you may want to keep all possible colours and hope the user's monitor does not mess the image up, but with graphics you are designing yourself, it helps if you can use browser safe colours wherever possible.

Valid colour values for the safety palette always use only the following hexadecimal colour values for each of the three colours.

00	66	CC
33	99	FF

The same colours in decimal format are:

0	102	204
51	153	255

Notes

### 4.5.3 Dithering

Of course, 256 colours won't cover everything. Images reduced to 256 colours and screens that are trying to display colours that are beyond their capacity rely on something called dithering to represent colours.

What dithering tries to do is represent intermediary colours between two displayable colours by mixing pixels of those two colours together in close proximity to create the illusion of the intermediary colour. Close inspection, of course, reveals dots of two different colours. Dithering greatly degrades images and should be either actively made use of at the design stage to control it, or avoided by sticking with a safety palette and no dithering.



*Notes* Dithering can be a problem in GIF images and other images using a 256-color palette. It is not a problem if you are using 24-bit images.

Figure 4.21: An image Showing Dithering

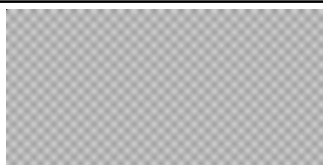

Source: <http://www.colormatters.com/web-safe-color-palette>

### 4.5.4 Gamma Correction

Gamma is a measure of the contrast between the mid-level grey values in an image.

Figure 4.22: Image showing Contrast between the mid-level Grey Values

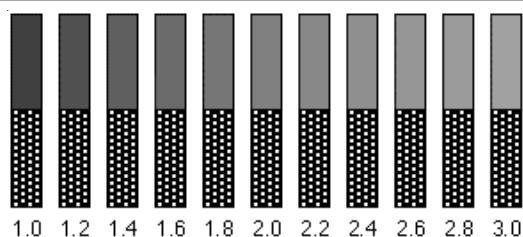

Source: <http://www.colormatters.com/web-safe-color-palette>

Since Gamma affects contrast, it is very important for graphics, particularly because Windows and Macintosh both have drastically different default Gamma levels for their monitors. Windows images look washed out on Macintosh systems. Macintosh images look dark on Windows systems. Usually the solution is to lighten Macintosh images slightly and darken Windows images slightly so that they will look more or less correct on either system.

Most good graphics editors will let you play with the Gamma, so that you can see the differences. PNG images can also auto correct for Gamma.

**Notes**

The images above and below are ways of testing Gamma on a computer screen. In the first example, move back from the screen until one of the bars looks to be a solid shade of grey all the way through. The number beneath that is your screen's current Gamma setting.

In the example below, all of the boxes should be a different shade of grey. The gradation between them should be somewhat consistent across the entire series, which is to say each step darker or lighter look like it is roughly the same amount. If the boxes near the ends are indistinguishable from the boxes on the ends, then your gamma needs adjusting.

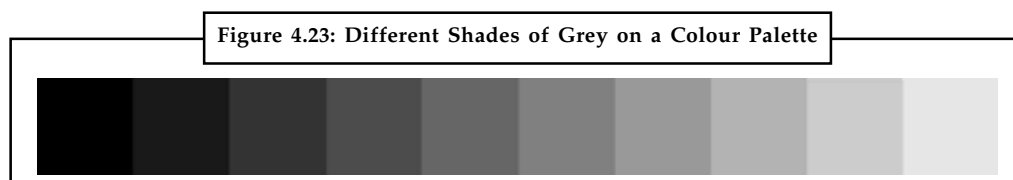

Source: <http://www.colormatters.com/web-safe-color-palette>

### 4.5.5 Bandwidth Issues

A major challenge with Web images is overcoming bandwidth issues. Bandwidth is a catch-all term for measuring how fast people can download Web content. By definition, graphic images take up far more bandwidth than text. Remember to consider carefully the images you are going to use. Images should be visual tools, not fancy trappings. The point of Web page graphics is to support text content and make the navigation and structure of online documents easier to understand. Use images to clarify and illustrate.

There are, of course, exceptions to the rule. If your site exists to market your abilities with high end Web animation programs, then you probably want a huge site with plenty of fancy things on it, otherwise keep it simple. Always ask whether an image has a purpose on a page. If not, take it out.

Some image use guidelines for dealing with bandwidth:

**Keep it simple. Keep it small.** The recommended maximum size for Web graphics is 30 kb. The recommended maximum size for a page is 100 kb, with images. Another measure is whether all critical content loads within 30 seconds on a 28 kbps modem. If your content has to be large, have an introductory page warning people of this and then give them the option of going there.

**Use image management tools** to reduce palette sizes. Simplify your drawings. Avoid large, empty background spaces and gratuitous borders. Try to avoid dithering. See how far you can compress an image and still have it be usable.

**Turn off anti-aliasing.** Anti-aliasing tries to smooth out an image by blending it with the background colour. This can cause problems where the image is a transparent GIF or PNG, creating a halo around the image where the colour was blurred.

**Reuse images.** Images, when downloaded, are cached, or stored, on the local computer, which means that if you use them across multiple pages then they only have to be downloaded once.

**Break up large documents.** Store large documents as separate chapters or even pages. Imagine if I had stored all these lecture notes as one continuous document instead of small ones of one lecture each.

**Specify image dimensions.** Telling the page how big the image is up front allows it to set aside space for it on the page, rather than having to download the image to figure out how large the image is and then re-display the page to account for the image when loaded.

## 4.5.6 Colour Palette Generator

Notes

A colour generator or colour scheme selector is a tool for anyone in need of a colour scheme. In most cases, these online tools are code driven and full of features to help someone build the perfect colour scheme. There is somewhere around 50 online generators available for you to use.

1. **Degraeve.com Colour Palette Generator:** This generator is a simple tool that creates a colour scheme from an image. The best part of this tool is you can find an image online and instead of downloading the image, you can get the link of the image and paste it into the URL image field. Once you hit the button that says "Colour-Palette-ify!" It will display ten colours that are found in the image. The image given below is taken from flickr and then passed through the generator. The generator pulled colours that match the colour of the image. Even a user cannot use the image in a project he can use the colours for inspiration. This tool is very handy, easy to use, and finds the most important colours of the images quickly.











Figure 4.24: Degraeve.com Colour Palette Generator

**DeGraeve.com**

### Color Palette Generator

Enter the URL of an image to get a color palette that matches the image. This is useful for coming up with a website color palette that matches a key image a client wants to work with.

URL of image:

	dull	vibrant
	 #111100	 #111100
	 #554433	 #774433
	 #aa4433	 #ff4411
	 #bbcccc	 #ffffff
	 #779999	 #99cccc

If you like this color palette generator, you might like [ColorHunter.com](#)

Source: <http://www.evolutionarydesigns.net/blog/2010/08/27/color-palette-generators/>

2. **Colour Scheme Designer:** Colour Scheme Designer is the colour generator that most designers use the most. This tool provides a better preview, permanent URL for the

Notes

scheme you create, loaded with a ton of features, and in my opinion, one of the best looking interfaces around.

Figure 4.25: Color Scheme Designer

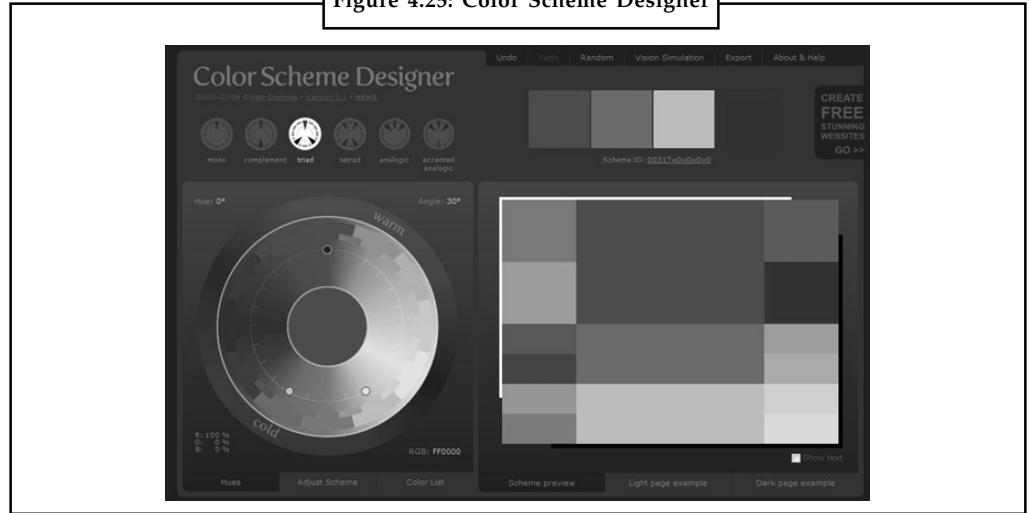

Source: <http://www.evolutionarydesigns.net/blog/2010/08/27/color-palette-generators/>

3. **Kuler Colour Generator by Adobe:** Adobe Kuler is tool for generating colour themes. You can create a theme from an image or from a colour selector. You can even choose a mood, and it will pick colours that are defined by a particular mood. You can save your theme and share it with the Kuler community. Or if you are interested in what others are creating, you can browser other Kuler users and even grab their theme colours for your project. Kuler impresses me, it got a lot of features, great community, and it's easy to create a colour theme. The interface is all designed beautifully.

Figure 4.26: Theme created from an Image



Source: <http://www.evolutionarydesigns.net/blog/2010/08/27/color-palette-generators/>

4. **CSS Drive: Colour Palette Generator:** CSS Drive's generator is a generator like DeGraeve's colour generator. But with this generator, you can either upload an image from the web or upload from your computer. Once you get the image uploaded, you choose a light, medium, or a dark colour palette. If you want more colours, you can also use the complete list of

colours in this image. Once you select the colours you want or if you want to grab all the colours, you. You have the option of download a file that lists all the CSS colour codes or a Photoshop colour swatch file. This a great tool if you want something simple to grab colours form image, and still see all the colours available in the image.

Figure 4.27: Theme Created from an Image

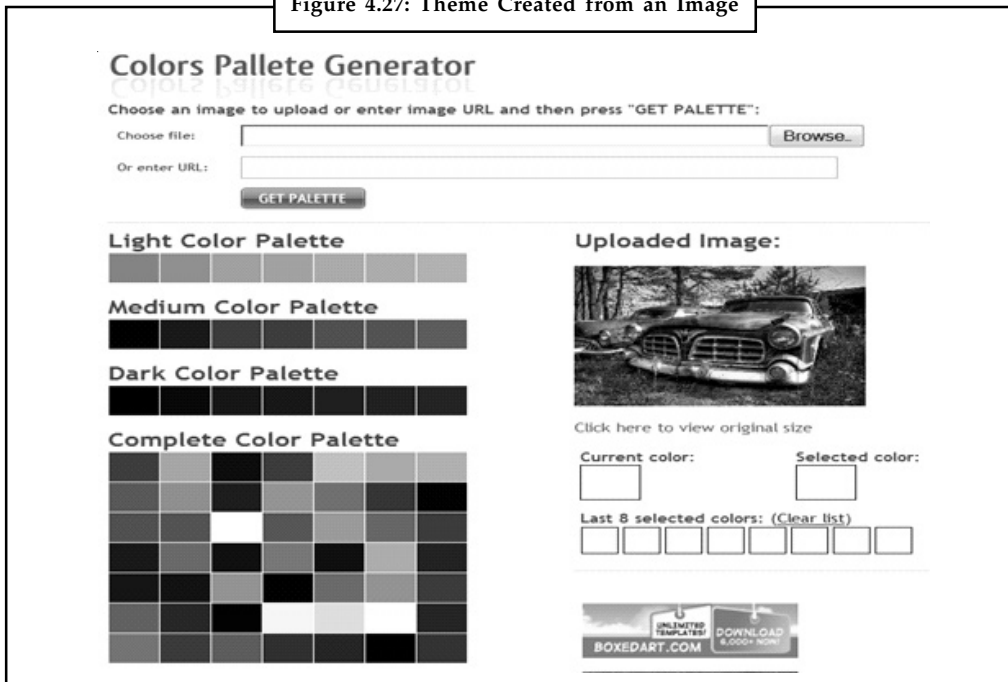

Source: <http://www.evolutionarydesigns.net/blog/2010/08/27/color-palette-generators/>

5. **Colour Schemer:** Colour Schemer is simple to use. Pick a colour and it gives you sixteen colours to create your colour palette from. If you like this tool and want a desktop version, they do offer one.

Figure 4.28: Color Schemer

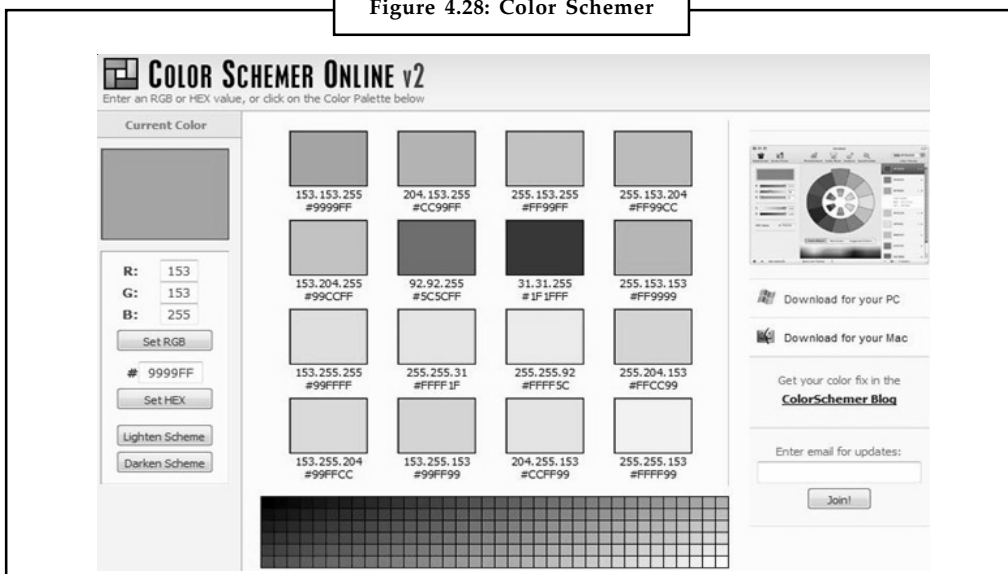

Source: <http://www.evolutionarydesigns.net/blog/2010/08/27/color-palette-generators/>

## **4.6 Image File Formats**

When you prepare a graphic or a document that you'll distribute to others, how much thought do you give to the file format? Do you know which file format is best for a particular application? If you send a file in the wrong format, some data loss may occur or the recipient may not be able to use the file at all.

Just a few years ago, you probably created and printed a project using only one application. Now, it's common to create an illustration in one program, add to it in another, and then print it in a third. Therefore, in order to freely exchange information between applications, you must know which file formats work in each application. This is especially true when you're working with graphic files.

Two or three years ago, a Mac user would never have heard of a PCX or BMP file, and a PC user wouldn't know a MacPaint file from a PICT file. But now that more applications are becoming cross-platform, desktop publishers need to familiarize themselves with graphic file formats that were previously platform-specific.

Keeping current on all the graphic file formats available for one platform is difficult enough-for two or more platforms, it's close to impossible. But technology marches on, and in that spirit we're presenting some of the most commonly used graphic file formats on the Mac and Windows platforms.

So how do you select a file format? That really depends on the application in which you intend to use the image. Let's review each of the image formats to see which works best for you.

### **4.6.1 Graphics Interchange Format (GIF)**

The Graphics Interchange Format (GIF) is a bitmap image format that was introduced by CompuServe in 1987 and has since come into widespread usage on the World Wide Web due to its wide support and portability.

The format is almost universally used to support up to 8 bits per pixel, thus allowing a single image to reference a palette of up to 256 distinct colours chosen from the 24-bit RGB colour space. Although the format can technically support 24-bit colour, this is considered bad practice and results in inflated image sizes. It also supports animations and allows a separate palette of up to 256 colours for each frame. The normal colour limitation makes the GIF format unsuitable for reproducing colour photographs and other images with continuous colour, but it is well-suited for simpler images such as graphics or logos with solid areas of colour.

GIF images are compressed using the Lempel-Ziv-Welch (LZW) lossless data compression technique to reduce the file size without degrading the visual quality. This compression technique was patented in 1985. Controversy over the licensing agreement between the software patent holder, Unisys, and CompuServe in 1994 spurred the development of the Portable Network Graphics (PNG) standard.

GIF files start with a fixed-length header ("GIF87a" or "GIF89a") giving the version, followed by a fixed-length Logical Screen Descriptor giving the size and other characteristics of the logical screen. The screen descriptor may also specify the presence and size of a Global Color Table, which follows next if present.

Thereafter, the file is divided into segments, each introduced by a 1-byte sentinel:

- An image (introduced by 0x2C, a comma ',')
- An extension block (introduced by 0x21, an exclamation point '!')



- The trailer (a single byte of value 0x3B, a semi-colon ';'), which should be the last byte of the file.

An image starts with a fixed-length Image Descriptor, which may specify the presence and size of a Local Colour Table (which follows next if present). The image data follow: one byte giving the bit width of the unencoded symbols (which must be at least 2 bits wide, even for bi-colour images), followed by a linked list of sub-blocks containing the LZW-encoded data.

### 4.6.2 Portable Network Graphics (PNG)

The Portable Network Graphics (PNG) format was designed to replace the older and simpler GIF format and, to some extent, the much more complex TIFF format. Here we'll concentrate on two major uses: the World Wide Web (WWW) and image-editing.

For the Web, PNG really has three main advantages over GIF: alpha channels (variable transparency), gamma correction (cross-platform control of image brightness), and two-dimensional interlacing (a method of progressive display). PNG also compresses better than GIF in almost every case, but the difference is generally only around 5 per cent to 25 per cent, not a large enough factor to encourage folks to switch on that basis alone. One GIF feature that PNG does not try to reproduce is multiple-image support, especially animations; PNG was and is intended to be a single-image format only. (A very PNG-like extension format called MNG was finalized in mid-1999 and is beginning to be supported by various applications, but MNGs and PNGs will have different file extensions and different purposes.)

PNG supports three main image types: true color, grey scale and palette-based (8-bit). JPEG only supports the first two; GIF only the third (although it can fake grey scale by using a grey palette).

For image editing, either professional or otherwise, PNG provides a useful format for the storage of intermediate stages of editing. Since PNG's compression is fully lossless – and since it supports up to 48-bit true colour or 16-bit grey scale – saving, restoring and re-saving an image will not degrade its quality, unlike standard JPEG (even at its highest quality settings). And unlike TIFF, the PNG specification leaves no room for implementers to pick and choose what features they'll support; the result is that a PNG image saved in one app is readable in any other PNG-supporting application. (Note that for transmission of finished true colour images – especially photographic ones – JPEG is almost always a better choice. Although JPEG's lossy compression can introduce visible artefacts, these can be minimized, and the savings in file size even at high quality levels is much better than is generally possible with a lossless format like PNG. And for black-and-white images, particularly of text or drawings, TIFF's Group 4 fax compression or the JBIG format are often far better than 1-bit grey scale PNG.)

Like GIF and TIFF, PNG is a raster format, which is to say, it represents an image as a two-dimensional array of coloured dots (pixels). PNG is explicitly not a vector format, i.e., one that can store shapes (lines, boxes, ellipses, etc.) and be scaled arbitrarily without any loss of quality (generally speaking). For that you probably want SVG or PostScript. (There are some private extensions to PNG that add vector information in addition to PNG's regular pixels – Macromedia's Fireworks does something along those lines – but no valid PNG may omit the pixel data.)

### 4.6.3 Joint Photographic Experts Group (JPEG)

JPEG compression is used in a number of image file formats. JPEG/Exif is the most common image format used by digital cameras and other photographic image capture devices; along with JPEG/JFIF, it is the most common format for storing and transmitting photographic images on the World Wide Web. These format variations are often not distinguished, and are simply called JPEG.

**Notes**

The term "JPEG" is an acronym for the Joint Photographic Experts Group, which created the standard. The MIME media type for JPEG is image/jpeg (defined in RFC 1341), except in Internet Explorer, which provides a MIME type of image/pjpeg when uploading JPEG images. JPEG/JFIF supports a maximum image size of 65535×65535.

This is the format of choice for nearly all photographs on the web. You can achieve excellent quality even at rather high compression settings. I also use JPG as the ultimate format for all my digital photographs. If I edit a photo, I will use my software's proprietary format until finished, and then save the result as a JPG.

Digital cameras save in a JPG format by default. Switching to TIFF or RAW improves quality in principle, but the difference is difficult to see. Shooting in TIFF has two disadvantages compared to JPG: fewer photos per memory card, and a longer wait between photographs as the image transfers to the card.

JPEG may not be as well suited for line drawings and other textual or iconic graphics, where the sharp contrasts between adjacent pixels can cause noticeable artifacts. Such images may be better saved in a lossless graphics format such as TIFF, GIF, PNG, or a raw image format. The JPEG standard actually includes a lossless coding mode, but that mode is not supported in most products.

JPEG is also not well suited to files that will undergo multiple edits, as some image quality will usually be lost each time the image is decompressed and recompressed, particularly if the image is cropped or shifted, or if encoding parameters are changed. To avoid this, an image that is being modified or may be modified in the future can be saved in a lossless format, with a copy exported as JPEG for distribution.

## **4.7 Macintosh Image Format**

Macintosh PICT is a graphics file format introduced on the original Apple Macintosh computer as its standard metafile format. It allows the interchange of graphics (both bitmapped and vector), and some limited text support, between Mac applications, and was the native graphics format of QuickDraw. The PICT file format consists essentially of serialized QuickDraw opcodes. The original version, PICT 1, was designed to be as compact as possible while describing vector graphics. To this end, it featured single byte opcodes, many of which embodied operations such as "do the previous operation again". As such it was quite memory efficient, but not very expandable. With the introduction of the Macintosh II and Colour QuickDraw, PICT was revised to version 2. This version featured 16-bit opcodes and numerous changes which enhanced its utility. PICT 1 opcodes were supported as a subset for backward compatibility.

### **4.7.1 File Organization**

All Macintosh PICT files start with a 512-byte header, which contains information that the Macintosh use to keep track of the file. This is followed by three fields describing the image size (picSize), the image frame (picFrame), and a version number. In v2.0 files, another header follows. In both versions, the preceding information is followed by the image data. In all versions, the end of the file is signalled by an end-of-file operator.

Within a Mac application, any sequence of drawing operations could be simply recorded/encoded to the PICT format by opening a "Picture", then closing it after issuing the required commands. By saving the resulting byte stream as a resource, a PICT resource resulted, which could be loaded and played back at any time. The same stream could be saved to a data file on disk (with 512 bytes of unused header space added) as a PICT file. With the change to OS X and deprecation of QuickDraw, PICT was dropped in favour of Portable Document Format (PDF) as the native metafile format, though PICT support is retained by many applications as it was so widely supported on Classic Mac OS.

## 4.8 Windows Imaging File Format (WIM)

Notes

Windows Imaging Format may also go by the acronym WIM. It is a file-based disk image format introduced by Microsoft to facilitate the deployment of Windows Vista and later versions of the Windows OS. These operating systems make use of WIF as part of the standard installation process. Similar to many other disk image formats, a WIF file includes a group of files and related file-system metadata. However, in contrast to sector-based formats like .CUE/.BIN and .ISO (used by DVD and CD images), WIM is file-based, meaning that the most basic unit of data is a file.

The WIF image format is hardware independent – a key advantage that allows it to work on 32-bit or 64-bit systems. WIF also supports disk image installation on any partition, regardless of size. In contrast, sector-based image formats may only be installed in partitions of equal size or less.

A WIF file is capable of storing multiple images referenced by the file's corresponding index or unique name. This capability is enhanced by Microsoft's single-instance storage (SIS) technology, which is used to store one file copy after determining whether there are multiple file copies. SIS and WIF's compression feature may be combined to reduce WIF file size.

In order to create, edit and set up Windows disk images in the Windows Imaging Format, a command-line tool called ImageX is used. Users can avail it as part of the Windows Automated Installation Kit (WAIK). Beginning from Windows Vista, Windows Setup makes use of the WAIK API to set up new and cloned Windows installations.

### 4.8.1 WIM File Structure

Figure 4.29: WIM File Structure

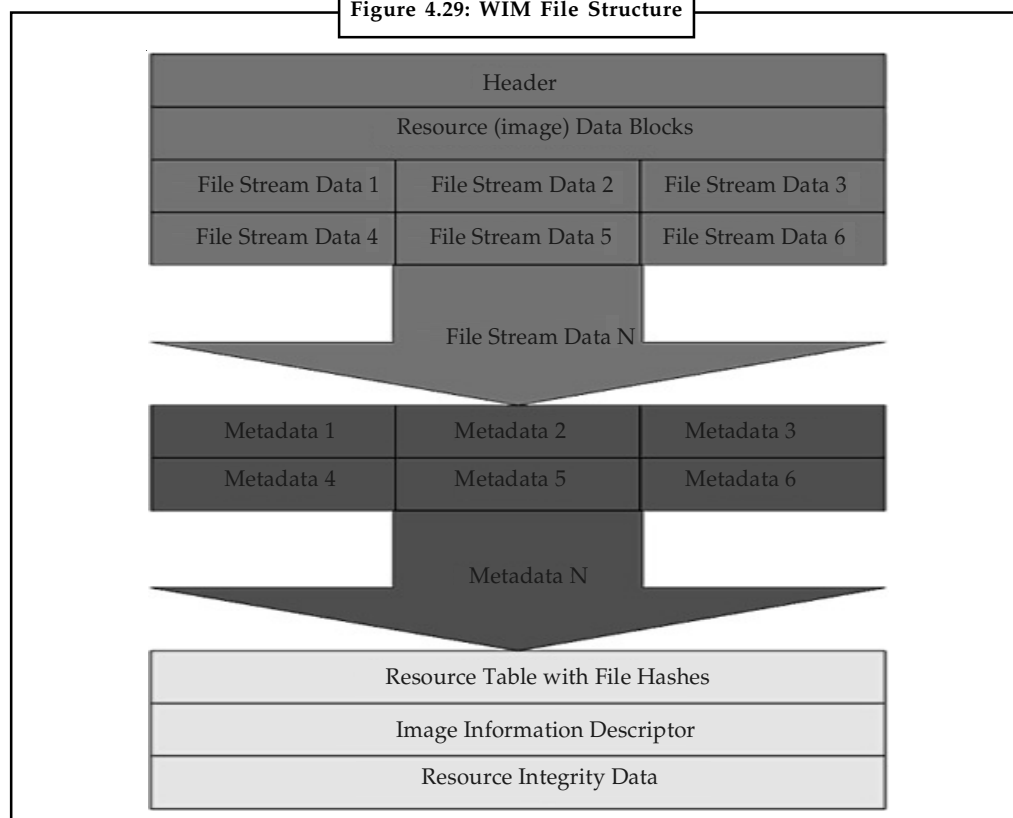

Source: <http://i.technet.microsoft.com/dynimg/IC71108.jpg>

**Notes**

A WIM file structure (See Figure 4.29) contains up to six types of resources: header, file resource, metadata resource, lookup table, XML data, and integrity table. The following illustration shows the general layout of a WIM file that contains two images.

### 4.8.2 WIM File Layout

- File resources is a series of packages that contain captured data, such as source files.
- XML data contains additional data about the image.
- WIM header defines the content of the .wim file, including memory location of key resources (metadata resource, lookup table, XML data), and various .wim file attributes (version, size, compression type).
- Integrity table contains security hash information that is used to verify an image's integrity during an apply operation.
- Metadata resource contains information about the files that you are capturing, including directory structure and file attributes. There is one metadata resource for each image in a .wim file.
- Lookup table contains the memory location of resource files in the .wim file.

### 4.8.3 Benefits of Leveraging WIM

There are a number of additional benefits in leveraging the Windows Imaging format over sector-by-sector copying. Some highlights:

- One WIM file can address different hardware configurations as there is no requirement as in a sector-by-sector copy installs that the destination hardware match the source hardware.
- WIM can store multiple images within a single file as described above in the install .wim of the base operating system; the same can be done for custom \*.wim files created by system administrator.
- When you store multiple images within a single file you can do this as just part of a core build for desktop deployments or with the use of Catalog (CLG) files that allow for the option to set up multiple applications to be deployed as part of the operating system build.
- You can service the WIM image off-line from its stored location and add or remove certain operating system components, files, updates, and drivers without creating a new image.
- Windows Imaging format has the flexibility to install a disk image on partitions of any size. Sector-by-sector images require deployments of an image to a partition that is the same size or larger than the source disk.
- WIMGAPI is the Windows Imaging API that developers can use to manage WIM image files.
- WIM deployments can be performed non-destructively. Data can be on the existing volume and the image can be deployed without erasing the existing contents of the volume.

## 4.8.4 Understanding Windows Image Files and Catalog Files

Notes

Windows System Image Manager (Windows SIM) uses Windows image (.wim) files and catalog (.clg) files to display the available components and packages that can be added to an unattended answer file. Windows images and catalog files contain configurable settings that you can modify once the component or package is added to an answer file.

### Windows Image Files

A Windows image (.wim) file contains one or more compressed Windows images. Each Windows image in a .wim file contains a list of all of the components, settings, and packages available with that Windows image.

### Limitations of Windows Image Files

The following list describes some of the limitations of using .wim files:

- Windows image files can be opened only by an account with administrator privileges.
- Windows image files can be opened only by one user at a time.
- Because Windows image files can contain one or more Windows images, they tend to be large. Some Windows image files can be several gigabytes (GB) in size.
- The settings in a Windows image can change over time. Windows SIM enables you to create an answer file in which the settings are modified, added, or removed. Windows image files also change when packages are added, configured, or removed. By running Setup and then applying the answer file, the new settings and configurations are applied. If you recapture the installed Windows image by using ImageX, the new settings and configurations are now the defaults. When a Windows image changes, you must create a new catalog file.
- Because of these limitations, Windows SIM uses catalogs when creating an answer file.

### Catalog Files

A catalog file is a binary file that lists the state of all the settings and packages in a Windows image. When a catalog is created, it queries the Windows image for a list of all the settings in that image. Because the contents of a Windows image can change over time, it is important that you recreate the catalog file whenever you update a Windows image.

Because Windows images can be opened only by administrators, you must have administrator privileges on the system to create a catalog file.

The Windows retail DVD includes pre-generated catalog files for each Windows image inside `install.wim`. These catalog files are in the `Sources` directory of the retail DVD and can be used to create an answer file for a Windows image in the default `install.wim` file. However, if you intend to create a catalog for a custom Windows image, you should use Image Manager to recreate the catalog for that custom Windows image.

### Contents of a Catalog File

The catalog contains the following information:

- A list of component settings and current values.
- Windows features and package states.

Notes

### Benefits of Catalog Files

Catalog (.clg) files have several advantages over .wim files

- Significantly smaller than Windows image (.wim) files, .clg files can be less than 1 MB, while .wim files can be several GB in size. Also, .clg files are easier to copy to removable media or a network share.
- While .clg files enable multiple users to create answer files for a single .clg file at the same time, a .wim file enables only one person to open and to access the .wim file at any given time.
- Non-administrators can create answer files for a .clg file. However, .wim files can be opened only by administrators.

### 4.8.5 WIMGAPI Tool for Windows Image Deployment

The WIMGAPI is the Windows Imaging Application Program Interface that developers can use to manage .wim files.

Developers are able to use WIMGAPI to mount existing WIM files to a folder in order to revise the contents or adding or remove files or settings from the image and then returning the image (unmount) from the folder. The WIMGAPI can also be used to partition a hard drive and format the volumes ahead of dropping the WIM onto the system as part of the installation being executed.

## 4.9 Cross-platform Formats

The format of an image to be used on the Web should be a file type that is "cross-platform" which means that several types of operating systems can use that file type. Platforms are operating systems and system configurations such as a Macintosh running OS X on the G4 with dual processors, a PC running Windows XP, or another computer running the Linux operating system. The images will need to be in a format that all of the computers operating on the Web can use. Popular file formats for Web use are the GIF and JPEG file formats. All graphical browsers support GIF and JPEG file formats. PNG file formats can only be recognized by some of the graphical browsers but not all of them.

### 4.9.1 Cross-platform Problems in Current Scenario

With existing formats, there are substantial cross-platform differences with image viewing. The images will be displayed, sure, but what people see will be very different.



*Example:* Create a graphic on a Mac, say, and balance it to look just right this picture of two children. In which trouble is, it will look dark and contrast on a PC, because the default gamma correction is different from that on a Mac. On an SGI workstation, however, it will look pale and washed-out because there the gamma is different again.

The problem is that your browser has no idea where the image was created or how it was originally displayed, so it cannot compensate for these differences. What is needed is for the authoring tools to include this information, which is readily available to them. But existing image formats have no way of storing this information.

Notes

Figure 4.30 Images in Different Cross Platform Formats

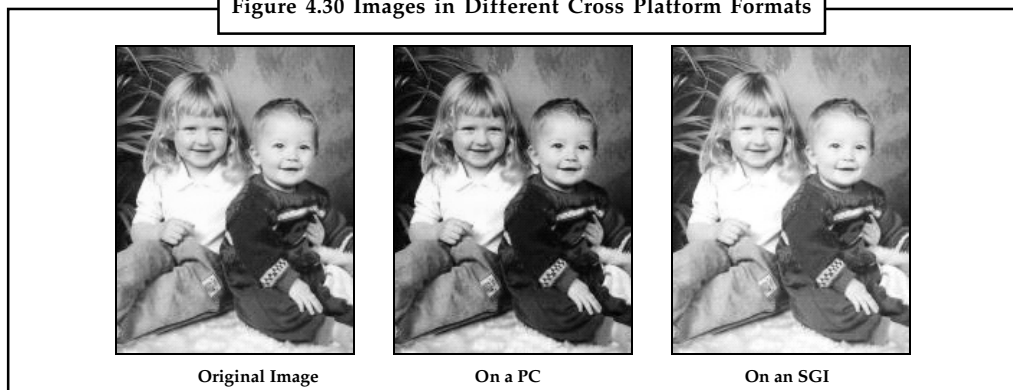

Source: <http://www.w3.org/Graphics/PNG/platform.html>

### With the Help of PNG

The PNG stores the gamma value used by the source platform which created the image, in a standard place in the file which browsers, image viewers and authoring tools know how to read and adjust for. So the gross lightness and contrast differences we have just seen are compensated for automatically, without the image designer or the reader having to make any adjustments themselves. (See Figure 4.31)

Figure 4.31: PNG Image on Different Platforms

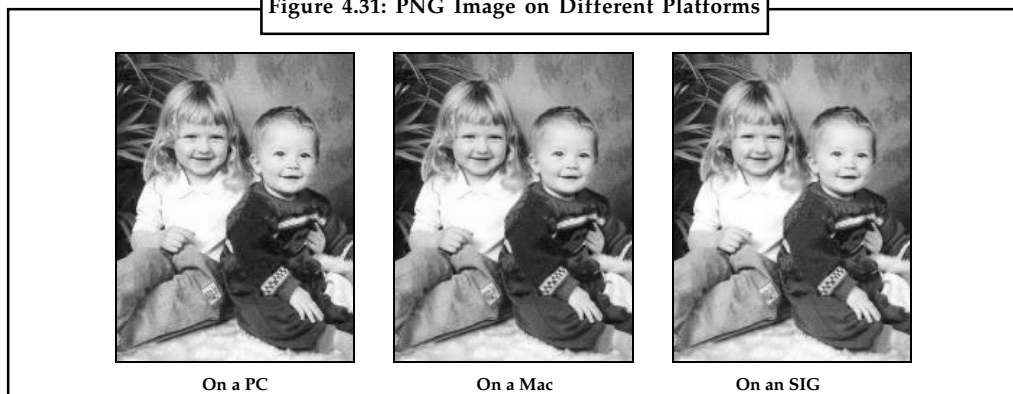

Source: <http://www.w3.org/Graphics/PNG/platform.html>

### More Cross Platform Problems

Figure 4.32: Cross platform Problems

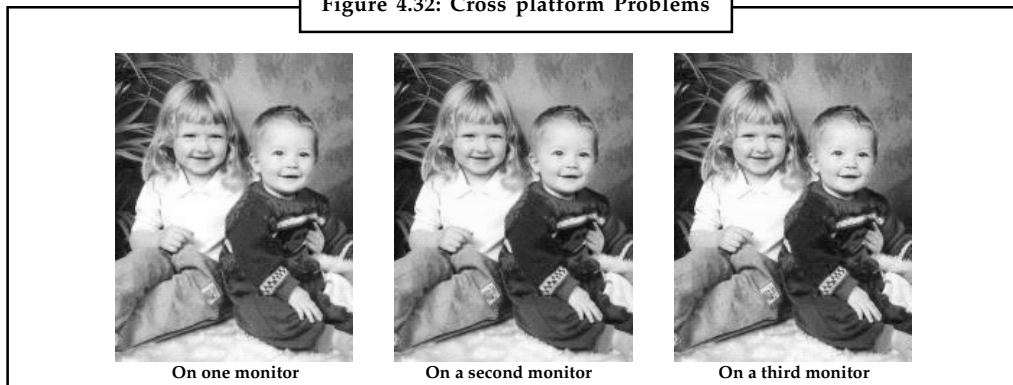

Source: <http://www.w3.org/Graphics/PNG/platform2.html>

Notes

**Not Quite the Right Colour**

These three pictures show the same image as it might appear when displayed on three different monitors. The type of computer doesn't matter so much here, though we assume that appropriate gamma correction has already been done.

Although very similar, there are clear differences in the green of the leaves, the shade of blue on the boy's arm, and the colour of the girl's shirt and the children's faces.

Looking at any of the shirts, you wouldn't want to order a garment thinking it was an off-white and then find it was actually cream, or beige. Sometimes, you need to be sure you are seeing the right colour. But the more you look, the more the same image looks different on each monitor.

**Why is that?**

This effect is caused by differences in the exact shade of red, green and blue light that each monitor emits. Different brands use different phosphors – the light emitting chemicals that generate the picture we see – and the precise shade of white differs quite a lot, too. (Think how many shades of white paint you can buy nowadays).

It is easiest to discuss the effect using a diagram. Don't worry about what the numbers mean (they are colour measurements, called chromaticity), concentrate on the shape.

Figure 4.33: The Colour Gamut of a Typical Colour Monitor

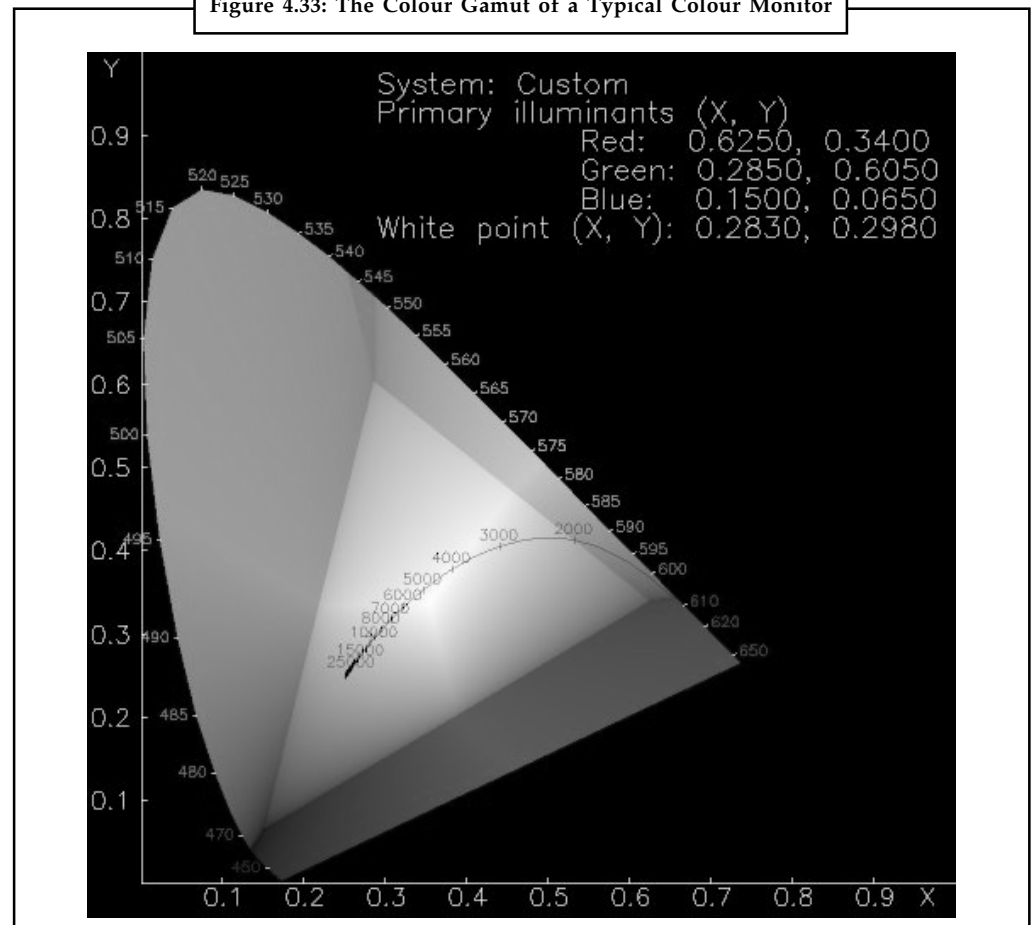

Source: <http://www.w3.org/Graphics/PNG/platform2.html>



- The hoop shape represents the limit of all the colours that the human eye can see. A rainbow spectrum would wrap right around the curved edge. Pastel colours and white are in the middle.
- The triangle represents the colours that can be displayed on one particular monitor. As you can see, there are many colours that can't be displayed.
- The curved black line shows a range of possible whites, ranging from warm orangish whites on the right such as you get from an electric light bulb through to cool bluish whites on the left. The monitor will display just one of these whites, a single point on the curved black line.

Now imagine a different triangle and a different white point, representing a different monitor. Take all the colours on the first monitor's triangle and stretch it, like a rubber sheet, to fit the new triangle. Clearly, all the colours move and become different colours. That is the effect shown above.

### How PNG helps

PNG stores the chromaticity values – the position of the triangle corners, plus the white point used by the source platform which created the image, in a standard place in the file which browsers, image viewers and authoring tools know how to read and adjust for. Together with the gamma, which we discussed earlier, this permits automatic adjustment to get very close to the colours you would measure from the original image.

When you prepare a graphic or a document that you will distribute to others, how much thought do you give to the file format? Do you know which file format is best for a particular application?

Just a few years ago, you probably created and printed a project using only one application. Now, it is common to create an illustration in one program, add to it in another, and then print it in a third. Therefore, in order to freely exchange information between applications, you must know which file formats work in each application. This is especially true when you are working with graphic files.

Two or three years ago, a Mac user would never have heard of a PCX or BMP file, and a PC user would not know a MacPaint file from a PICT file. But now that more applications are becoming cross-platform. Desktop publishers need to familiarize themselves with graphic file formats that were previously platform-specific.

Keeping current on all the graphic file formats available for one platform is difficult enough-for two or more platforms, it is close to impossible. But technology marches on, and in that spirit we are presenting some of the most commonly used graphic file formats on the Mac and Windows platforms. In this, we will first review the basics behind image file format, and then we will outline each of the most popular image file types.

XnView is a cross-platform image viewer used for viewing, converting, organising and editing graphical and video files. It is free of charge for private, educational and non-profit organisations. For commercial use and distribution, the user must register the program.

XnView is highly customizable and multi-lingual, supporting 44 languages in the Windows version. The language can be changed via the options menu. The toolbar buttons can be modified to a certain extent, or be replaced by altering skins.

Also, XnView has been able to support an increasing number of file formats (mainly image file formats). It can read more than 400 image file formats, some audio and video file formats, and write 50 image file formats. XnView also supports ICC profiles in JPEG, PNG and TIFF files.

**Notes**

XnView can show IPTC, Exif and XMP metadata, and write IPTC metadata (but cannot do batch writing of IPTC metadata, and some users are longing for the batch IPTC editing function). A further limitation is that it currently does not allow sorting thumbnails within a folder by a user-defined order.

**Self Assessment**

State whether the following statements are true or false:

6. Rendering is used to describe the process of calculating effects in a video editing file to produce final video output.
7. Degraeve.com is a colour palette generator.
8. Refraction is the bending, spreading and interference of light passing by an object or aperture that disrupts the ray.
9. LCD stands for Liquid Crystal Diode.
10. Diffraction is the phenomenon of light being deflected while passing through different mediums.



*Case Study*

**Picture Library for Multimedia**

**A**n online product enjoys great success due to its excellent content, ease of use, and established market presence. A large global publisher wishes to enhance the presentation of its articles by adding a large number of high quality photographs and illustrations.

Traditionally, publishers would have contracts with many photo agencies that would present what they had available in the various categories, then editors would select the most promising candidates. Photos would go through a process of review until the winners were selected.

This process was time consuming and expensive. Along with the per photo charges, there are costs to the organization of personnel, researchers, editorial, etc.

The client engaged Value Chain International Ltd. (VCIL) to source and manages a sizeable number of photos and illustrations in a short timeframe. VCIL was selected due to its knowledge different types of content, its ability to execute process engineering for advanced and changing workflows, and the expertise and willingness to explore new avenues to achieve the client's goals.

**Business Solution**

The client did not have the resources or the expertise to complete this large project alone, so it engaged VCIL to source a number of photos within an aggressive deadline.

VCIL quickly put together a photo research team to populate a huge photographic database to significantly add to the client's collection of quality photographs.

As the photographic database was so large, VCIL developed appropriate management procedures to make sure the database would be populated smoothly, efficiently and effectively. Images were optimally organized in the database to ensure quick and easy access.

*Contd....*

## Notes

VCIL had the industry connections and the expertise to source and sift through mounds of photographic and pictorial materials available to find the hidden gems.

### Approach

VCIL supports the publisher throughout its entire lifecycle. VCIL was always available to quickly bring in new functionality and workflow enhancements to meet the particular requirements of the task at hand.

The client wanted a lot of images in a short timeframe. VCIL quickly put together a nimble and agile team of researchers who worked on an accelerated timetable. Engaging VCIL meant that the client didn't have the expense and problems in hiring and managing 30 independent photo researchers, or organizing the photos.

To complete a big project quickly over three different continents – in India, the US, and the UK – there are the usual problems of communication, assignments of roles and responsibilities, and long distance co-ordination over time zones. VCIL had the experience and the skills to implement superior procedures and a reliable model to source, manage and organize all the photos and illustrations. VCIL is uniquely positioned to assemble, train and expand the research team to successfully deliver to the client the results they were looking for.

VCIL provides a departure to how people tend to think of companies in India who just do digital conversion. VCIL has the knowledge and the skills in understanding content; process engineering; and workflow design and execution to build a scalable, highly accurate, and replicable model for the creation of a large amount of content.

### Benefits

An image database populated with a large number of photographs and illustrations is proving invaluable for quick and easy access to relevant images for a wide variety of articles. This has saved the company time and money in sourcing quality images from a plethora of suppliers. The client's articles are enhanced by the addition of high quality photographs and illustrations, which also inspire interest in the article.

### Questions:

1. Explain the case study given above in about 150 words.
2. Critically analyse image formatting in multimedia.

Source: [http://www.syncordia.com.au/docs/Large\\_Publisher.pdf](http://www.syncordia.com.au/docs/Large_Publisher.pdf)

## 4.10 Summary

- Rendering is the process of generating an image from a model (or models in what collectively could be called a scene file), by means of computer programs.
- Colour palette is a subset of all possible colours a monitor can display that is being used to display the current document.
- A colour generator or colour scheme selector is a tool for anyone in need of a colour scheme.
- Windows Imaging Format is a file-based disk image format introduced by Microsoft to facilitate the deployment of Windows Vista and later versions of the Windows OS.
- A Windows image (.wim) file contains one or more compressed Windows images. Each Windows image in a .wim file contains a list of all of the components, settings, and packages available with that Windows image.

**Notes**

- A catalog file is a binary file that lists the state of all the settings and packages in a Windows image.
- The WIMGAPI is the Windows Imaging Application Program Interface that developers can use to manage .wim files.
- The format of an image to be used on the Web should be a file type that is “cross-platform” which means that several types of operating systems can use that file type.

**4.11 Keywords**

*Bitmap (BMP):* A standard format used by Windows to store device-independent and application-independent images.

*Dither:* Blends the colours in the new palette to approximate the original colours in the graphic.

*Pixels:* Tiny units with a fixed width and height, and they can store various ranges of colours according to the image type.

*Resolution:* A measure of how finely a device displays graphics with pixels.

*Vector images:* These images are made up of co-ordinates, shapes, line, and colour data.

**4.12 Review Questions**

1. Explain bitmap images in detail.
2. What is a resolution? What is the difference between high resolution and lower resolution?
3. Write a note on colour depth conversion.
4. What is vector drawing? Describe.
5. Talk about various image formats in detail.
6. What is a colour palette and what are colour palette generators?
7. Describe various cross-platform problems in current scenario.
8. Write about catalog file and its advantages.
9. List all the limitations of Windows Image Files.
10. Explain bitmap image compression.

**Answers: Self Assessment**

- |         |           |
|---------|-----------|
| 1. (c)  | 2. (b)    |
| 3. (d)  | 4. (a)    |
| 5. (c)  | 6. True   |
| 7. True | 8. False  |
| 9. True | 10. False |

### 4.13 Further Readings

Notes



Books

Frederick P, Brooks, Jr., Kenan Professor of Computer Science. *The Mythical Man-Month: Essays in Software Engineering*. University of North Carolina at Chapel Hill.

K. Andleigh and K. Thakkar, *Multimedia System Design*, PHI, PTR.

Steve Rimmer (2000), *Advanced Multimedia Programming*, MHI.

Tay Vaughan, *Multimedia Making it work*, Seventh Edition. Tata McGraw-Hill Education Private Ltd.



Online links

<http://nora.lis.uiuc.edu:3030/companion/view?docId=blackwell/9781405103213/9781405103213.xml&doc.view=print&chunk.id=ss1-2-10&toc.depth=1&toc.id=0>

<http://styleguides.uark.edu/11888.php>

[http://users.mct.open.ac.uk/yr258/papers/Rogers\\_Scaife98.pdf](http://users.mct.open.ac.uk/yr258/papers/Rogers_Scaife98.pdf)

<http://www.icheg.org/icheg-game-history/timeline/>

<http://www.ict.griffith.edu.au/teaching/1611ICT/mm1alectures/111/Writing%20For%20Multimedia%20Great%20Moments%20In%20Multimedia%20History.htm>

## Unit 5: Video

### CONTENTS

Objectives

Introduction

- 5.1 How Video Works?
  - 5.1.1 Using Video
- 5.2 Broadcast Video Standards
  - 5.2.1 National Television System Committee (NTSC)
  - 5.2.2 Phase Alternating Line (PAL)
  - 5.2.3 Systeme Electronique Pour Couleur Avec Memoire (SECAM)
  - 5.2.4 Advanced Television Systems Committee (ATSC)
  - 5.2.5 Digital Television (DTV)
- 5.3 Analogue Video
- 5.4 Digital Video
- 5.5 Digital Video Standards—ATSC, ISDB, EDTV
  - 5.5.1 Advanced Television Systems Committee (ATSC)
  - 5.5.2 Integrated Services Digital Broadcasting (ISDB)
  - 5.5.3 Enhanced Definition Television Systems (EDTV)
- 5.6 Video Recording and Shooting Videos
  - 5.6.1 Shooting Platform
  - 5.6.2 Story Boarding
  - 5.6.3 Lighting
  - 5.6.4 Chroma Keys
  - 5.6.5 Composition
- 5.7 Video Editing
  - 5.7.1 Linear Video Editing
  - 5.7.2 Non-linear Editing (NLE)
- 5.8 Optimizing Video Files for CD-ROM
- 5.9 Digital Display Standards
  - 5.9.1 Monochrome Display Adapter (MDA)
  - 5.9.2 Hercules Graphics Card
  - 5.9.3 Colour Graphics Adapter (CGA)
  - 5.9.4 Enhanced Graphics Adapter (EGA)
  - 5.9.5 Video Graphics Array (VGA)
  - 5.9.6 Super VGA (SVGA)

Contd....

- |                       |
|-----------------------|
| 5.10 Summary          |
| 5.11 Keywords         |
| 5.12 Review Questions |
| 5.13 Further Readings |

## Objectives

After studying this unit, you will be able to:

- Describe how video works
- Understand broadcast video standards
- Elucidate analogue video
- Understand digital video
- Explain digital video standards —ATSC, DVB, ISDB
- Understand video recording and shooting videos
- Describe video editing
- Elucidate optimizing video files for CD-ROM
- Explain digital display standards

## Introduction

Video is a combination of image and audio. It consists of a set of still images called frames displayed to the user one after another at a specific speed, known as the frame rate measured in number of frames per second (fps). If displayed fast enough our eye cannot distinguish the individual frames, but because of persistence of vision merges the individual frames with each other thereby creating an illusion of motion. The frame rate should range between 20 and 30 for perceiving smooth realistic motion. Audio is added and synchronized with the apparent movement of images. The recording and editing of sound has long been in the domain of the PC. Doing so with motion video has only recently gained acceptance. This is because of the enormous file size required by video.



*Example:* One second of 24-bit, 640 × 480 mode video and its associated audio requires 27 MB of space, i.e. (640 × 480 pixels) (24 bits/pixel) (30 frames/sec). Thus, a 20 minute dip fills up 32 GB of disk space.

Since the first silent film movie flickered to life, people have been fascinated with “motion” pictures. To this day, motion video is the element of multimedia that can draw gasps from a crowd at a trade show or firmly hold a student’s interest in a computer-based learning project. Digital video is the most engaging of multimedia venues, and it is a powerful tool for bringing computer users closer to the real world. It is also an excellent method for delivering multimedia to an audience raised on television. With video elements in your project, you can effectively present your messages and reinforce your story, and viewers tend to retain more of what they see. But take care! Video that is not thought out or well produced can degrade your presentation.

## **5.1 How Video Works?**

When light reflected from an object passes through a video camera lens, that light is converted into an electronic signal by a special sensor called a charge-coupled device (CCD). Top-quality broadcast cameras and even camcorders may have as many as three CCDs (one for each colour of red, green, and blue) to enhance the resolution of the camera and the quality of the image. It's important to understand the difference between analogue and digital video.

Analogue video has a resolution measured in the number of horizontal scan lines (due to the nature of early cathode-tube cameras), but each of those lines represents continuous measurements of the colour and brightness along the horizontal axis, in a linear signal that is analogous to an audio signal. Digital video signals consist of a discrete colour and brightness (RGB) value for each pixel. Digitizing analogue video involves reading the analogue signal and breaking it into separate data packets. This process is similar to digitizing audio, except that with video the vertical resolution is limited to the number of horizontal scan lines. For some multimedia projects you may need to digitize legacy analogue video. The following discussion will help you understand the differences between analogue and digital video and the old and new standards for horizontal lines, aspect ratios, and interlacing.

### **5.1.1 Using Video**

Carefully planned, well-executed video clips can make a dramatic difference in a multimedia project. A clip of John F. Kennedy proclaiming "Ich bin ein Berliner" in video and sound is more compelling than a scrolling text field containing that same speech. Before deciding whether to add video to your project, however, it is essential to have an understanding of the medium, its limitations, and its costs. This unit provides a foundation to help you understand how video works, the different formats and standards for recording and playing video, and the differences between computer and television video. The equipment needed to shoot and edit video, as well as tips for adding video to your project, are also covered.

Video standards and formats are still being refined as transport, storage, compression, and display technologies take shape in laboratories and in the marketplace and while equipment and post-processing evolves from its analogue beginnings to become fully digital, from capture to display. Working with multimedia video today can be like a Mojave Desert camping trip: you may pitch your tent on comfortable high ground and find that overnight the shifting sands have buried both your approach and your investment. Of all the multimedia elements, video places the highest performance demand on your computer or device—and its memory and storage. Consider that a high-quality colour still image on a computer screen could require as much as a megabyte or more of storage memory. Multiply this by 30—the number of times per second that the picture is replaced to provide the appearance of motion—and you would need at least 30 megabytes of storage to play your video for one second, more than 1.8 gigabytes of storage for a minute, and 108 gigabytes or more for an hour. Just moving all this picture data from computer memory to the screen at that rate would challenge the processing capability of a supercomputer. Some of the hottest and most arcane multimedia technologies and research efforts have dealt with compressing digital video image data into manageable streams of information. Compression (and decompression), using special software called a codec, allows a massive amount of imagery to be squeezed into a comparatively small data file, which can still deliver a good viewing experience on the intended viewing platform during playback.

If you control the delivery platform for your multimedia project, you can specify special hardware and software enhancements that will allow you to work with high-definition, full-motion video, and sophisticated audio for high-quality surround sound. Or you can design a project to meet a specific compression standard, such as MPEG2 for Digital Versatile Disc (DVD) playback or



MPEG4 for home video. You can install a superfast RAID (Redundant Array of Independent Disks) system that will support high-speed data transfer rates. You can include instructions in your authoring system that will spool video clips into RAM, ready for high-speed playback before they need to play. Having control of the playback platform is always good, but it is seldom available in the real world, so as you develop your video elements, you will need to make many choices and compromises based upon your assessment of the “lowest common denominator” playback platform where your project will be used.

## **5.2 Broadcast Video Standards**

Broadcast-safe video (broadcast legal or legal signal) is a term used in the broadcast industry to define video and audio compliant with the technical or regulatory broadcast requirements of the target area or region the feed might be broadcasting to. In the United States, the Federal Communications Commission (FCC) is the regulatory authority; in most of Europe, standards are set by the European Broadcasting Union (EBU).

When configuring a desktop computer or laptop computer to connect to an external video source such as a TV or a projector, users in the United States should configure the video or BIOS for NTSC as the external video or video source. Users outside the United States should select the option for PAL.

Digital broadcasting is very different from analogue. The NTSC and PAL standards describe both transmission of the signal and how the electrical signal is converted into an image. In digital, there is a separation between the subject of how data is to be transmitted from tower to TV, and the subject of what content that data might contain. While data transmission is likely to be a fixed and consistent affair, the content could vary from High Definition video one hour, to SD multi-casting the next, and even to non-video data casting. In the US, 8VSB transmits the data, while MPEG-2 encodes pictures and sound.

### **5.2.1 National Television System Committee (NTSC)**

NISC is a television broadcasting system used in a number of countries including Korea, Japan, Canada, North America, parts of South America, Mexico and the Caribbean islands. It is named after the National Television Systems Committee, the industry wide standardization body that created it. The National Television Systems committee was set up in 1940 by the Federal Communication Commission in the United States to establish a nationwide standard for black and white TV transmission.

It specified a standard using 525 horizontal lines, 30 frames per sec, 2 interlaced fields per frame (also called 11 interlacing, 262,5 lines per field, 60 fields per second, an aspect ratio of 43 and frequency modulation for the audio signal (Frequency modulation is a form of modulation which represents information as variations in the instantaneous frequency of a carrier wave), in 1950 the Committee was reconstituted to establish a standard for colour's transmission, which would be at the same time compatible with the existing format for B/W TV. As per the recommendations of the Committee, colour information was added to the black and white image by adding a colour sub-carrier to the video signal (A sub-carrier is a separate analogue or digital signal carried on a main transmission signal, which contains some extra information).

An NTSC television channel as transmitted occupies a total bandwidth of 6 MHz. A guard band, which does not carry any signals, occupies the lowest 250 kHz of the channel, to avoid any known possibility of interference between the video signal of one channel and the audio signals of the next channel down. The actual video signal, which is amplitude-modulated, is transmitted between 500 kHz and 5.45 MHz above the lower bound of the channel. The video carrier is 1.25 MHz above the lower bound of the channel. Like any modulated signal, the video carrier generates two sidebands, one above the carrier and one below.

**Notes**

The sidebands are each 4.2 MHz wide. The entire upper sideband is transmitted, but only 750 kHz of the lower sideband, known as a vestigial sideband, is transmitted. The colour sub-carrier, as indicated above, is 3.579545 MHz above the video carrier, and is quadrature-amplitude-modulated. The highest 250 kHz of each channel contains the audio signal, which is frequency-modulated, making it compatible with the audio signals broadcast by FM radio stations in the 88-108 MHz band. The main audio carrier is 4.5 MHz above the video carrier. Sometimes, a channel can contain an MTS signal, which is simply more than one audio signal. This is normally the case when stereo audio and/or SAP signals are used.

Video professionals and television engineers do not hold NTSC video in high regard, joking that the abbreviation stands for “Never The Same Colour” or “Never Tested Since Christ”. For one, the interlaced picture (drawing every other horizontal line of video in one pass, and filling in the others in the second) complicates editing video. Additionally, radio interference tends to degrade an NTSC picture, so the picture often loses its colour balance by the time the viewer receives it (this necessitates the inclusion of a “tone” or “hue” control on NTSC sets, which is not necessary on PAL or SECAM systems). And finally, some complain that the 525 line resolution of NTSC results in a lower quality image than the hardware is capable of.



*Did u know?* In 1941, the first NTSC standard was developed that had no provision for colour television.

### 5.2.2 Phase Alternating Line (PAL)

PAL, short for Phase Alternating Line, is the analogue video format used in television transmission in most of Europe (except France, Bulgaria, Russia, Yugoslavia, and some other countries in Eastern Europe, where SECAM is used), Australia and some Asian, African, and South American countries. PAL was developed in Germany by Walter Bruch, and first introduced in 1967.

The name “Phase Alternating Line” describes the way that part of the colour information on the video signal is reversed in phase with each line, which automatically corrects phase errors in the transmission of the signal. NTSC receivers have a tint or hue control to perform the correction manually. Some engineers jokingly expand NTSC to “Never The Same Colour” while referring to PAL as “Perfect At Last” or “Peace At Last”! However, the alternation of colour information – Hanover bars – can lead to picture grain on pictures with extreme phase errors.

The PAL colour system is usually used with a video format that has 625 lines per frame and a refresh rate of 25 frames per second. Like NTSC this is an interlaced format. Each frame consists of two fields (half-a-frame), each field has half of the lines of a frame (one has all the even lines, one has all the odd lines). Fields are transmitted and displayed successively. There are 50 fields per second. At the time of its design, the interlacing of fields was a compromise between flicker and bandwidth.

There are many variants of PAL. PAL-M is a hybrid of NTSC and PAL with 525 lines/60 Hz used in Brazil and PAL-N is a variant of PAL with narrow bandwidth which is used in Argentina, Paraguay, and Uruguay. PAL-I is the version used in the United Kingdom. Other European countries use PAL-B/G. A variant named PAL60 uses, like NTSC, 59.94 fields per second. It is used mainly for displaying NTSC video or DVD on a PAL TV set.

Similar to NTSC, PAL also uses a colour sub-carrier signal with two amplitude modulated quadrature sub-components, however the colour sub-carrier signal is located at 4.43 MHz instead of 3.579545 MHz in case of NTSC. The name “phase alternating lines” describes the way that the phase part of the colour information is reversed with each which automatically helps to correct phase errors in the transmission of the signal by cancelling them out. Moreover the use of

625 lines as against 525 for NTSC leads to a better quality picture. PAL is therefore sometimes jokingly referred to as “Perfect At Last”, Out of the 625 lines, only 576 lines are actively used to display the image on the L screen, the remaining lines being used for synchronization and vertical retrace. To distinguish between those of NTSC, the PAL colour sub-components are referred to as U and V.

### Difference between NTSC and PAL

NTSC stands for National Television Standards Committee. PAL stands for Phase Alternating Line. NTSC is the standard broadcast format in the United States, while PAL is the standard broadcast format in Europe, Australia, and parts of Asia.

If you are an American who has tried to insert a movie from Europe into your DVD player, you will notice that the picture will be very scrambled and the sound quality will be absolutely terrible. The vast majority of DVD players that were manufactured for the United States are not backwards compatible with the PAL broadcast format.

Due to the electrical differences noted below, a PAL television would not work in the United States. The differences in resolution quality also account for why a PAL formatted DVD will not play properly on an NTSC player. If you must play an NTSC formatted DVD on a PAL DVD player, or vice versa, there are conversion kits available. These kits can convert NTSC to PAL or PAL to NTSC. The downside to these conversion kits is that they can be very time consuming and the quality of the movies may be reduced upon completion of the conversion.

**Electrical Differences:** Most people will not be able to easily tell the difference between NTSC and PAL. The main difference starts with the electrical power system that runs behind the colour transmissions. In the United States, electrical power is generated at 60 hertz. The signal behind the NTSC broadcast format is set to send out 60 fields per second. Most televisions use an interlaced system, so the NTSC signal sends out 30 lines of the image, followed by another 30 alternating lines. Basically, that results in 30 frames of a complete image appearing every single second.

In Europe and other countries, electrical power is generated at 50 hertz. Televisions that utilize PAL as the broadcast format only produce 25 frames of a complete image appearing every single second. This causes problems with the proper display of motion, as it makes actors move a bit faster because of the difference in frames per second that are showing movement. If you are trying to watch a PAL movie on a NTSC television, you need to add 5 frames per second, or the motion of the film will be very jerky or slow.

**Resolution Quality:** The other main difference between NTSC and PAL is resolution quality. While PAL produces fewer frames per second than NTSC, it produces more lines. An NTSC television will broadcast 525 lines of resolution, while a PAL television will broadcast 625 lines of resolution. As the lines of resolution increase, so does the amount of visual information. This produces better picture quality and screen resolution. If you were to try to convert an NTSC movie to PAL, black bars would most likely be added to compensate for the smaller screen aspect. The black bars would resemble what you would see in a widescreen or letterbox movie.

### 5.2.3 Systeme Electronique Pour Couleur Avec Memoire (SECAM)

SECAM (Sequential Electronique Pour Couleur Avec Mémoire, French for “sequential colour with memory”) is an analogue television system, using frequency modulation to encode chrominance information. It is so named because it uses memory to store lines of colour information, in order to eliminate the colour artefacts found on systems using the NTSC standard. It uses a 625-line vertical, 50-line horizontal display.

## Notes

It was developed for the same purpose as PAL, but uses a different (and many would argue inferior) mechanism to do so. R-Y and B-Y information is transmitted in alternate lines, and a video line store is used to combine the signals together. This means that the vertical colour resolution is halved relative to PAL and NTSC.

SECAM was introduced in France in 1967, where it is still used; it has also been adopted in many former French colonies, as well as parts of Eastern Europe (Bulgaria, Hungary) and the former Soviet Union. Many have argued that the primary motivation for the development of SECAM in France was to protect French television equipment manufacturers and make it more difficult to view non-French programming. Political factors from the Cold War have also been attributed to the adoption of SECAM in Eastern Europe, as its use made it impossible for most Eastern Europeans to view television which was broadcast from outside the Iron Curtain which were mostly using PAL.

There are three varieties of SECAM:

- French SECAM is used in France and its former colonies
- MESECAM is used in the Middle East
- D-SECAM is used in the Commonwealth of Independent States and Eastern Europe.

American engineers have been known to claim that SECAM stood for "System Essentially Contrary to the American Method".

Different types use different video bandwidth and audio carrier specifications. Types B and D are usually used for VHF. Types G, H, and K are used for UHF. Types I, N, M, K1 and L are used for both VHF and UHF. These different types are generally not compatible with one another. SECAM is sometimes irreverently referred to as "Something Essentially Contrary to the American Method" or "SEcond Color Always Magenta."

Unlike PAL or NTSC, analogue SECAM television could not easily be edited in its native form: instead, post-production was done in PAL, and the result then trans-coded into SECAM at the point of transmission.

### **PAL versus SECAM**

SECAM was developed arguably to protect French television equipment manufactures and to make it more difficult to view non-French programming. Unlike PAL, SECAM television could not be edited in its original form, instead post production was done in PAL and the result trans-coded into SECAM at the point of transmission. Another area where SECAM is different is the transmission of blue and red colours, with PAL and NTSC they are send concurrently where SECAM sends them alternatively. This means SECAM removes colour artefacts but halves colour resolution.

The SECAM is an earlier attempt at compatible colour television which also tries to resolve the NTSC hue problem. It does so by applying a different method to colour transmission, namely alternate transmission of the U and V vectors and frequency modulation, while PAL attempts to improve on the NTSC method.

### **5.2.4 Advanced Television Systems Committee (ATSC)**

The Advanced Television Systems Committee (ATSC) is a standards organization that was created in 1982 as part of the Advanced Television Committee (ATC) to promote the establishment of technical standards for all aspects of advanced television systems. Based in Washington, D.C., ATSC has grown from 25 original organizational members to an international membership of

over 200, including broadcasters, motion picture companies, telecommunications carriers, cable TV programmers, consumer electronics manufacturers, and computer hardware and software companies.

The ATSC developed standards for digital television (DTV) that specify technologies for the transport, format, compression, and transmission of DTV in the U.S. ATSC DTV Standards developed, or in development currently, include digital high definition television (HDTV), standard definition television (SDTV), data casting (the transmission of separate information streams that might allow, for example, someone watching a baseball game to choose a different camera angle, or someone watching a cooking show to view and download particular recipes), multichannel surround-sound audio, conditional access (methods, such as encryption or electronic locking systems, used to restrict service access to authorized users), and interactive services. For SDTV and HDTV, ATSC chose MPEG-2 for video and Dolby Digital for audio.

ATSC standards are expected to revolutionize the television industry as defined by the National Television Standards Committee (NTSC) standards set in 1953. ATSC standards for DTV are being adopted internationally.

### 5.2.5 Digital Television (DTV)

Digital Television (DTV) is an advanced broadcasting technology that has transformed your television viewing experience. DTV has enabled broadcasters to offer television with better picture and sound quality. It also offers multiple programming choices, called multi-casting, and interactive capabilities.

#### DTV Transition

The switch from analogue to digital broadcast television is referred to as the Digital TV (DTV) Transition. In 1996, the U.S. Congress authorized the distribution of an additional broadcast channel to each broadcast TV station so that they could start a digital broadcast channel while simultaneously continuing their analogue broadcast channel.

Later, Congress set June 12, 2009 as the deadline for full power television stations to stop broadcasting analogue signals. Since June 13, 2009, all full-power U.S. television stations have broadcast over-the-air signals in digital only.

#### Why Did We Switch to DTV?

An important benefit of the switch to all-digital broadcasting is that it freed up parts of the valuable broadcast spectrum for public safety communications (such as police, fire departments, and rescue squads). Also, some of the spectrum can now be auctioned to companies that will be able to provide consumers with more advanced wireless services (such as wireless broadband).

Consumers also benefited because digital broadcasting allows stations to offer improved picture and sound quality, and digital is much more efficient than analogue.



*Example:* Rather than being limited to providing one analogue program, a broadcaster is able to offer a super sharp High Definition (HD) digital program or multiple Standard Definition (SD) digital programs simultaneously through a process called “multi-casting.”

Multi-casting allows broadcast stations to offer several channels of digital programming at the same time, using the same amount of spectrum required for one analogue program.

## Notes



*Example:* So, while a station broadcasting in analogue on channel 7 is only able to offer viewers one program, a station broadcasting in digital on channel 7 can offer viewers one digital program on channel 7-1, a second digital program on channel 7-2, a third digital program on channel 7-3, and so on.

This means more programming choices for viewers. Further, DTV provides interactive video and data services that were not possible with analogue technology.

### 5.3 Analogue Video

In an analogue system, the output of the CCD is processed by the camera into three channels of colour information and synchronization pulses (sync) and the signals are recorded onto magnetic tape. There are several video standards for managing analogue CCD output, each dealing with the amount of separation between the components—the more separation of the colour information, the higher the quality of the image (and the more expensive the equipment). If each channel of colour information is transmitted as a separate signal on its own conductor, the signal output is called component (separate red, green, and blue channels), which is the preferred method for higher-quality and professional video work. Lower in quality is the signal that makes up Separate Video (S-Video), using two channels that carry luminance and chrominance information. The least separation (and thus the lowest quality for a video signal) is composite, when all the signals are mixed together and carried on a single cable as a composite of the three colour channels and the sync signal. The composite signal yields less-precise colour definition, which cannot be manipulated or colour-corrected as much as S-Video or component signals.

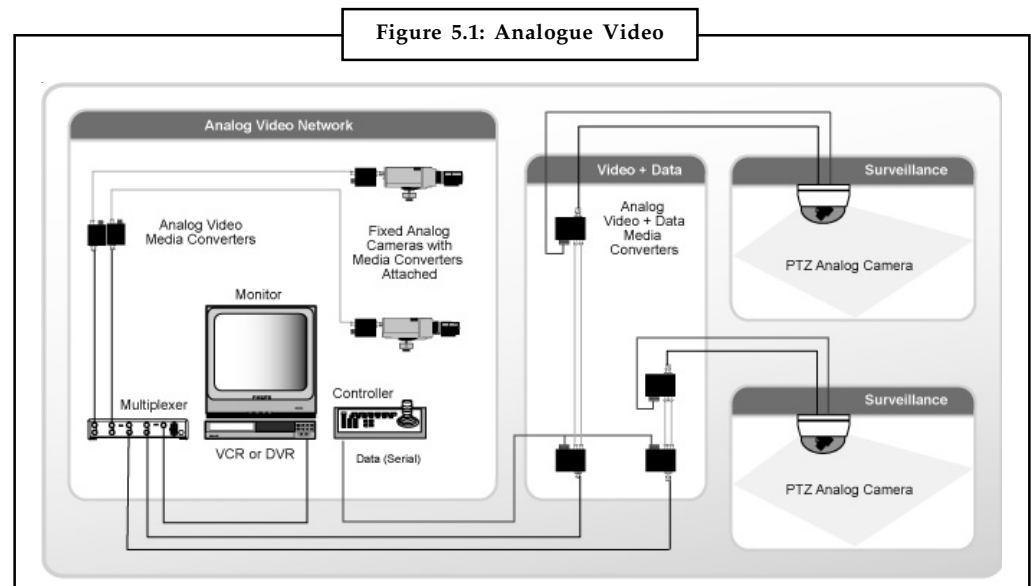

*Source:* <http://www.transition.com/TransitionNetworks/Resources/en/images/solutions/secure/ANALOG-VIDEO.gif>

The analogue video and audio signals are written to tape by a spinning recording head that changes the local magnetic properties of the tape's surface in a series of long diagonal stripes. Because the head is canted or tilted at a slight angle compared with the path of the tape, it follows a helical (spiral) path, which is called helical scan recording. As illustrated in Figure 5.1, each stripe represents information for one field of a video frame. A single video frame is made up of two fields that are interlaced (described in detail later in the unit). Audio is recorded on a separate straight-line track at the top of the videotape, although with some recording systems

## Notes

(notably for 3/4-inch tape and for 1/2-inch tape with high-fidelity audio), sound is recorded helically between the video tracks. At the bottom of the tape is a control track containing the pulses used to regulate speed. Tracking is the fine adjustment of the tape during playback so that the tracks are properly aligned as the tape moves across the playback head. These are the signals your grandmother's VCR reads when you rent *Singing in the Rain* (on video cassette) for the weekend.

Many consumer set-top devices like video cassette recorders (VCRs) and satellite receivers add the video and sound signals to a sub-carrier and modulate them into a radio frequency (RF) in the FM broadcast band. This is the NTSC, PAL, or SECAM signal available at the Antenna Out connector of a VCR. Usually the signal is modulated on either Channel 3 or Channel 4, and the resulting signal is demodulated by the TV receiver and displayed on the selected channel. Many television sets today also provide a composite signal connector, a S-Video connector, and a High-Definition Multimedia Interface (HDMI) connector for purely digital input. Video displays for computers typically provide analogue component (red, green, blue) input through a 15-pin VGA connector and also a purely Digital Visual Interface (DVI) and/or an HDMI connection.

Three analogue broadcast video standards are commonly in use around the world: NTSC, PAL, and SECAM. In the United States, the NTSC standard has been phased out, replaced by the ATSC Digital Television Standard. Because these standards and formats are not easily interchangeable, it is important to know where your multimedia project will be used. A video cassette recorded in the United States (which uses NTSC) will not play on a television set in any European country (which uses either PAL or SECAM), even though the recording method and style of the cassette is "VHS." Likewise, tapes recorded in European PAL or SECAM formats will not play back on an NTSC video cassette recorder. Each system is based on a different standard that defines the way information is encoded to produce the electronic signal that ultimately creates a television picture. Multi-format VCRs can play back all three standards but typically cannot dub from one standard to another. Dubbing between standards still requires high-end, specialized equipment.

Figure 5.2: Analogue System Design

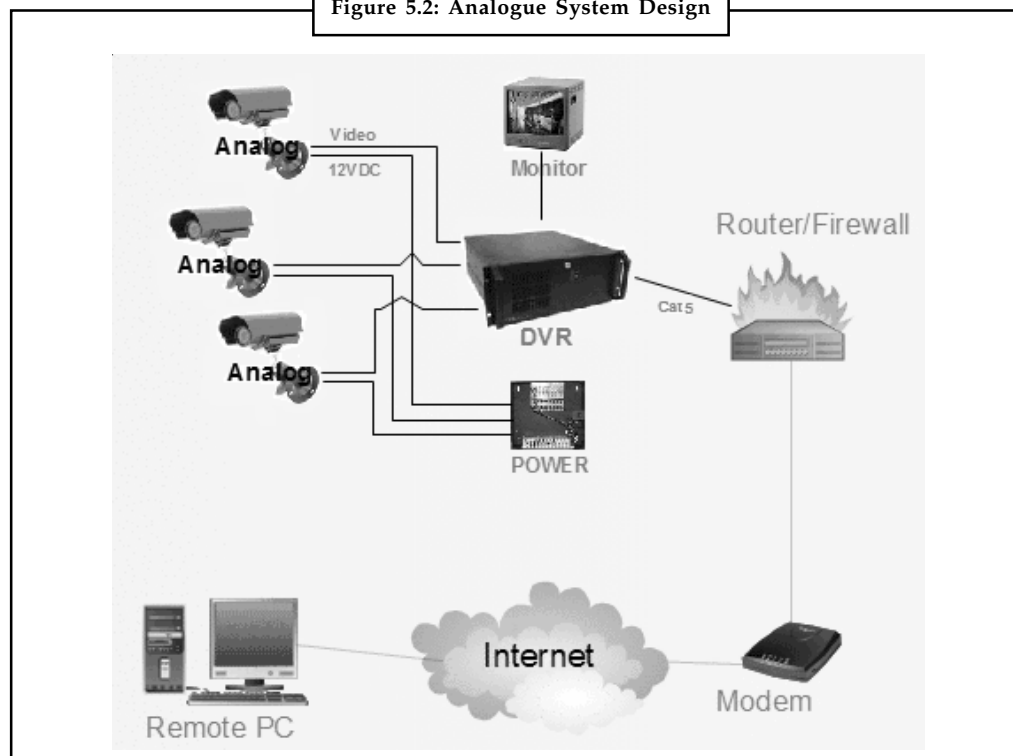

Source: <http://www.discount-security-cameras.net/images/products/detail/AnalogSystemDesign.gif>

## 5.4 Digital Video

In digital systems, the output of the CCD is digitized by the camera into a sequence of single frames, and the video and audio data are compressed before being written to a tape (see Figure 5.3) or digitally stored to disc or flash memory in one of several proprietary and competing formats. Digital video data formats, especially the codec used for compressing and decompressing video (and audio) data, are important; more about them later in this unit.

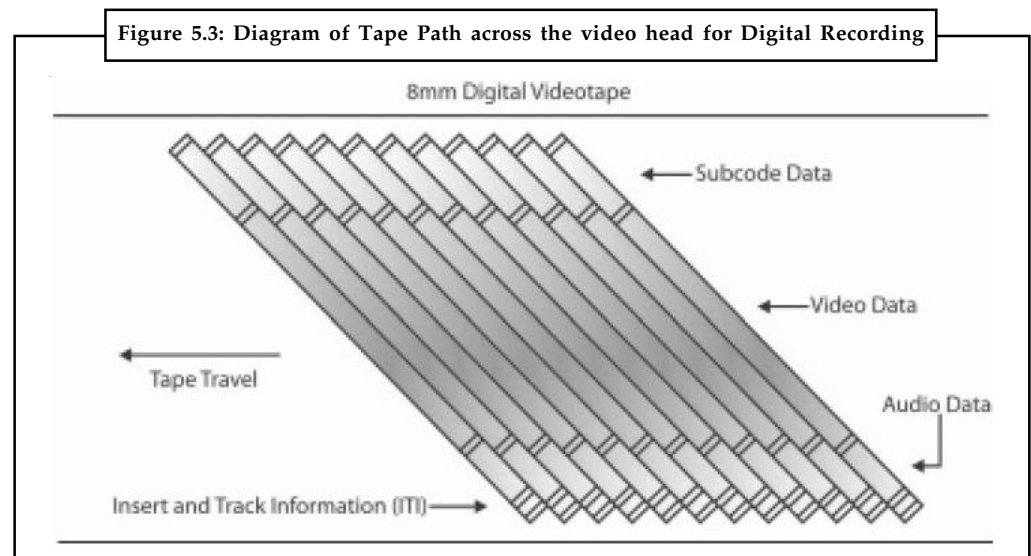

In 1995, Apple's FireWire technology was standardized as IEEE 1394, and Sony quickly adopted it for much of its digital camera line under the name i.Link. FireWire and i.Link (and USB 2) cable connections allow a completely digital process, from the camera's CCD to the hard disk of a computer; and camcorders store the video and sound data on an on-board digital tape, writable mini-DVD, mini-hard disk, or flash memory.

### HDTV

What started as the High Definition Television (HDTV) initiative of the Federal Communications Commission in the 1980s changed first to the Advanced Television (ATV) initiative and then finished as the Digital Television (DTV) initiative by the time the FCC announced the change in 1996. This standard, which was slightly modified from both the Digital Television Standard (ATSC Doc. A/53) and the Digital Audio Compression Standard (ATSC Doc. A/52), moved U.S. television from an analogue to a digital standard. It also provided TV stations with sufficient bandwidth to present four or five Standard Television (STV, providing the NTSC's resolution of 525 lines with a 3:4 aspect ratio, but in a digital signal) signals or one HDTV signal (providing 1,080 lines of resolution with a movie screen's 16:9 aspect ratio).

HDTV provides high resolution in a 16:9 aspect ratio (see Figure 5.4). This aspect ratio allows the viewing of Cinemascope and Panavision movies. There was contention between the broadcast and computer industries about whether to use interlacing or progressive-scan technologies. The broadcast industry promulgated an ultra-high-resolution, 1920 × 1080 interlaced format (1080i) to become the cornerstone of the new generation of high-end entertainment centres, but the computer industry wanted a 1280 × 720 progressive-scan system (720p) for HDTV. While the 1920 × 1080 format provides more pixels than the 1280 × 720 standard, the refresh rates are quite different. The higher resolution interlaced format delivers only half the picture every 1/60 of a second, and because of the interlacing, on highly detailed images there is a great deal of screen



flicker at 30 Hz. The computer people argue that the picture quality at  $1280 \times 720$  is superior and steady. Both formats have been included in the HDTV standard by the Advanced Television Systems Committee (ATSC), found at [www.atsc.org](http://www.atsc.org).

Notes

Figure 5.4: Here you can see the difference between VGA and HDTV aspect ratio

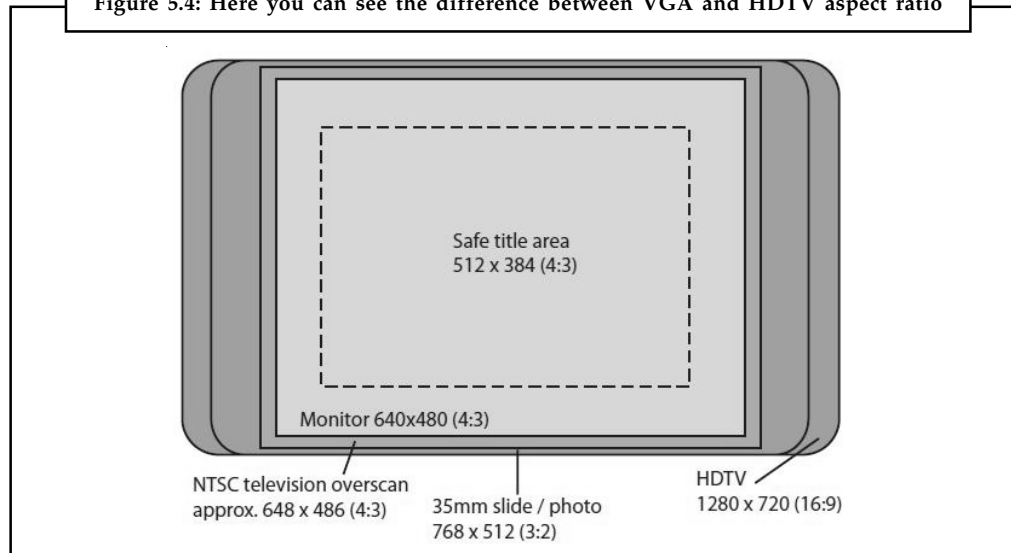

## Displays

Coloured phosphors on a cathode ray tube (CRT) screen glow red, green, or blue when they are energized by an electron beam. Because the intensity of the beam varies as it moves across the screen, some colours glow brighter than others. Finely tuned magnets around the picture tube aim the electrons precisely onto the phosphor screen, while the intensity of the beam is varied according to the video signal. This is why you needed to keep speakers (which have strong magnets in them) away from a CRT screen. A strong external magnetic field can skew the electron beam to one area of the screen and sometimes caused a permanent blotch that cannot be fixed by degaussing—an electronic process that readjusts the magnets that guide the electrons. If you had the misfortune to forget and wear a watch, the degausser might stop it permanently and then, if you are particularly unlucky, erase the magnetic strips on the credit cards in your wallet as well. If a computer displays a still image or words onto a CRT for a long time without changing, the phosphors will permanently change, and the image or words can become visible, even when the CRT is powered down. Screen savers were invented to prevent this from happening.

Flat screen displays are all-digital, using either liquid crystal display (LCD) or plasma technologies, and have supplanted CRTs for computer use. Some professional video producers and studios, however, prefer CRTs to flat screen displays, claiming colours are brighter and more accurately reproduced.



*Notes* Full integration of digital video in cameras and on computers eliminates the analogue television form of video, from both the multimedia production and the delivery platform. If your video camera generates a digital output signal, you can record your video direct-to-disk, where it is ready for editing. If a video clip is stored as data on a hard disk, CD-ROM, DVD, or other mass-storage device, that clip can be played back on a computer's monitor without special hardware.

## Notes

**DTV versus HDTV**

The Advanced Television Standards Committee (ATSC) has set voluntary standards for digital television. These standards include how sound and video are encoded and transmitted. They also provide guidelines for different levels of quality. All of the digital standards are better in quality than analogue signals. HDTV standards are the top tier of all the digital signals.

The ATSC has created 18 commonly used digital broadcast formats for video. The lowest quality digital format is about the same as the highest quality an analogue TV can display. The 18 formats cover differences in:

- **Aspect ratio:** Standard television has a 4:3 aspect ratio—it is four units wide by three units high. HDTV has a 16:9 aspect ratio, more like a movie screen.
- **Resolution:** The lowest standard resolution (SDTV) will be about the same as analogue TV and will go up to 704 x 480 pixels. The highest HDTV resolution is 1920 x 1080 pixels. HDTV can display about ten times as many pixels as an analogue TV set.
- **Frame rate:** A set's frame rate describes how many times it creates a complete picture on the screen every second. DTV frame rates usually end in "i" or "p" to denote whether they are interlaced or progressive. DTV frame rates range from 24p (24 frames per second, progressive) to 60p (60 frames per second, progressive).

Many of these standards have exactly the same aspect ratio and resolution — their frame rates differentiate them from one another. When you hear someone mention a "1080i" HDTV set, they're talking about one that has a native resolution of 1920 x 1080 pixels and can display 60 frames per second, interlaced.

Broadcasters get to decide which of these formats they will use and whether they will broadcast in high definition—many are already using digital and high-definition signals. Electronics manufacturers get to decide which aspect ratios and resolutions their TVs will use. Consumers get to decide which resolutions are most important to them and buy their new equipment based on that. Until the analogue shutoff date, broadcasters will have two available channels to send their signal—a channel for analogue, and a "virtual" channel for digital. Right now, people can watch an over-the-air digital signal only if they are tuned in to the broadcaster's virtual digital channel. After analogue broadcasting ends, the only signals people will receive over the air will be digital.

However, even though a digital signal is better quality than an analogue signal, it isn't necessarily high definition. HDTV is simply the highest of all the DTV standards. But whether you see a high-definition picture and hear the accompanying Dolby Digital® sound depends on two things. First, the station has to be broadcasting a high-definition signal. Second, you have to have the right equipment to receive and view it.



*Notes* DTV usually uses MPEG-2 encoding, the industry standard for most DVDs, to compress the signal to a reasonable size. MPEG-2 compression reduces the size of the data by a factor of about 55:1, and it discards a lot of the visual information the human eye would not notice was missing.

## **5.5 Digital Video Standards—ATSC, ISDB, EDTV**

Before going into the details of digitizing video and playback of video on a personal computer, let us first have a look at the existing digital video standards for transmission and playback.

### 5.5.1 Advanced Television Systems Committee (ATSC)

Notes

ATSC (Advanced Television Systems Committee) is the name of the technical standard that defines the digital TV (DTV) that the FCC has chosen for terrestrial TV stations. ATSC employs MPEG-2, a data compression standard. MPEG-2 typically achieves a 50-to-1 reduction in data. It achieves this by not retransmitting areas of the screen that have not changed since the previous frame.

Digital cable TV systems and DBS systems like DirecTV have devised their own standards that differ somewhat from ATSC. Their high-def set top boxes (STBs) conform to ATSC at their output connectors. Those systems use MPEG-2 or MPEG-4.

ATSC has 18 different formats. All TVs must be able to receive all of these formats and display them. The broadcaster chooses the format. Most TV sets will display only 1 or 2 of these formats, but will convert the other formats into these.

### 5.5.2 Integrated Services Digital Broadcasting (ISDB)

ISDB is maintained by the Japanese organization ARIB. The standards can be obtained for free at the Japanese organization DiBEG website and at ARIB. The core standards of ISDB are ISDB-S (satellite television), ISDB-T (terrestrial), ISDB-C (cable) and 2.6 GHz band mobile broadcasting which are all based on MPEG-2 or MPEG-4 standard for multiplexing with transport stream structure and video and audio coding (MPEG-2 or H.264), and are capable of high definition television (HDTV) and standard definition television. ISDB-T and ISDB-Tsb are for mobile reception in TV bands. 1seg is the name of an ISDB-T service for reception on cell phones, laptop computers and vehicles.

The concept was named for its similarity to ISDN, because both allow multiple channels of data to be transmitted together (a process called multiplexing). This is also much like another digital radio system, Eureka 147, which calls each group of stations on a transmitter an ensemble; this is very much like the multi-channel digital TV standard DVB-T. ISDB-T operates on unused TV channels, an approach taken by other countries for TV but never before for radio.

**Interaction:** Besides audio and video transmission, ISDB also defines data connections (Data broadcasting) with the internet as a return channel over several media (10Base-T/100Base-T, Telephone line modem, Mobile phone, Wireless LAN (IEEE 802.11) etc.) and with different protocols. This is used, for example, for interactive interfaces like data broadcasting (ARIB STD-B24) and electronic program guides (EPG).

**Receiver:** There are two types of ISDB receiver: Television and set-top box. The aspect ratio of an ISDB-receiving television set is 16:9; televisions fulfilling these specs are called Hi-Vision TV. There are three TV types: Cathode ray tube (CRT), plasma display panel (PDP) and liquid crystal display (LCD), with LCD being the most popular Hi-Vision TV on the Japanese market nowadays.

### 5.5.3 Enhanced Definition Television Systems (EDTV)

These are conventional systems modified to offer improved vertical and horizontal resolutions. One of the systems emerging in US and Europe is known as the Improved Definition Television (MTV). In TV is an attempt to improve NTSC image by using digital memory to double the scanning lines from 525 to 1050. The pictures are only slightly more detailed than NTSC images because the signal does not contain any new information. By separating the chrominance and luminance parts of the video signal, EDTV prevents cross-interference between the two. The Double Multiplexed Analogue Components (D2-MAC) standard is designed as an intermediate standard for transition from current European analogue standard to HDTV standard.

## 5.6 Video Recording and Shooting Videos

Before you head out to the field with your camcorder in hand, it is important to understand at least the basics of video recording and editing, as well as the constraints of using video in a multimedia project. Setting up a production environment for making digital video requires hardware that meets minimum specifications for processing speed, data transfer, and storage. There are many considerations to keep in mind when setting up your production environment, depending on the capabilities of your camcorder:

- Fast processor(s)
- Plenty of RAM
- Computer with FireWire (IEEE 1394 or i.Link) or USB connection and cables
- Fast and big hard disk(s)
- A second display to allow for more real estate for your editing software
- External speakers

Expensive professional video equipment and services may not yield proportionately greater benefits than if you used consumer-grade equipment and non-linear editors. Most likely, your goal is to expend resources without diminishing returns—in other words, to produce multimedia that is adequate and does its job, but doesn't break your bank. If you can, experiment with various combinations of video recording and playback devices hooked to your computer, and test the results using your multimedia-authoring platform.



*Caution* You can do a great deal of satisfactory work with consumer-grade video cameras and recording equipment, provided you understand the limitations of the technology.

### 5.6.1 Shooting Platform

Never underestimate the value of a steady shooting platform. A classic symbol of amateur home movies is shaky camera work. Using a tripod or even placing the camera on a stable platform, such as a rolled-up sweater on the hood of a car, can improve a shot. With a little care, and careful adjustment of the lockdown screws, a sturdy conventional tripod can do wonders. If you must shoot handheld, try to use a camera with an electronic image stabilization feature for static shots, use a "steady-cam" balancing attachment, or use camera moves and a moving subject to mask your lack of steadiness. Even using a rolling office chair and sitting facing the back with the camera balanced on the chair-back makes a convenient, stable dolly. If you must shoot handheld, set the camera's lens to the widest angle: at a wide angle, camera motion becomes smaller relative to the field of view and is thus less apparent.

And invest in an external microphone, like a Lavalier. It will give you better audio than the on-camera microphone during interviews, and you can easily hide it in the scene during general use. Or use a "shotgun" mic on a boom, with an operator who can "ride levels" by monitoring the recorded volume.

Most important, learn the features and controls of your camera—there are many tiny icons and menu selections! Study the manual. Experiment and practice. Stay organized—keep your extra batteries, spare memory cards and tapes, your charger and cables, and even your manual (in case you haven't studied it hard enough) in a good camera bag. Learn how to connect the camera to your computer and how to access your video footage with non-linear editing software. Learn how to use the editing software. If you are new to video, this is a steep learning curve with many

small annoyances, but it is forgiving: if you mess up your video, there is often something from it that can be recovered and used.

Many digital camcorders will allow you to choose 4:3 or 16:9 aspect ratios for your recording, one or the other. Unfortunately, there is no easy way to convert between these aspect ratios, so you should decide up front which to use in your multimedia project. As shown in Figure 5.5, there are three ways to convert from a 4:3 aspect ratio for display on a 16:9 aspect ratio screen: you can stretch the 4:3 image to fill the 16:9 frame (this distortion can make people look fat), you can zoom the width of the image to fit the 16:9 frame (you lose part of the top and bottom of the image), or you can place the image into the centre of the 16:9 frame (leaving empty pillars right and left).

There are two ways to convert from 16:9 to 4:3. The *Letterbox* or hard matte method produces blank bars at top and bottom, but leaves the original image untouched; *Pan and Scan*, on the other hand, loses both sides of the original image. When using the Pan and Scan method for conversion, editors will carefully pan across wide scenes to capture the best area to show. Videographers and widescreen movie-makers often consider a 4:3 “safe frame” area when setting up their wide shots, knowing that their work will be converted to 4:3 for the DVD aftermarket. Some DVDs use an anamorphic widescreen coding system to squeeze 16:9 widescreen image data into a DVD’s standard 4:3 aspect ratio format; with a compatible player, these “Enhanced for Widescreen Televisions” discs will play the original video properly on a 16:9 screen.

Figure 5.5 : Methods for Converting 4:3 and 16:9 aspect ratio in Video Production

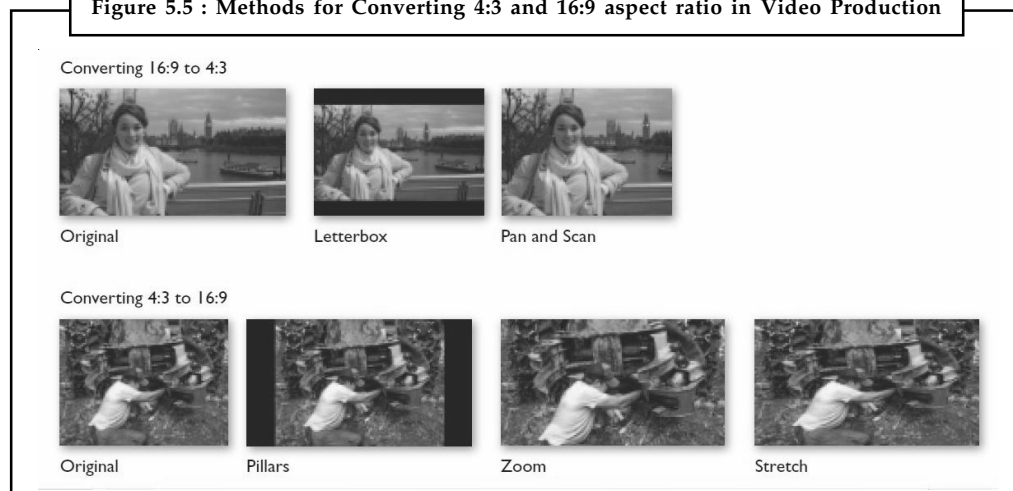

Source: Making it work by Tay Vaughan



*Notes* If your camera is HD-capable, it is a good idea to shoot your footage in HD. While it may be difficult to deploy HD video in your project due to bandwidth and memory constraints, you will have archived the footage at the highest resolution available to you. You can easily convert the high-definition source video to standard definition, but you cannot convert the other way without enhancer software that attempts to increase the resolution and make the video “good looking.”

## 5.6.2 Story Boarding

Pre-planning a video project is a factor that cannot be ignored without costing time loss, lots of unnecessary aggravation, and money that would be better spent elsewhere. Successful video

**Notes**

production, of any sort, deserves the time it takes to make a plan to carry it out. It may take a little time at first, but you'll find it to be very helpful in the long run. Storyboards are like any sequential comic you read daily. Every day there are three or four panels showing a progression of story or information. Take the time to structure your production by writing it down and then engineer a sequential group of drawings showing camera and scene, shooting angles, lighting, action, special effects, and how objects move through from start to finish. A storyboard can get everyone on one page quickly.

**5.6.3 Lighting**

Perhaps the greatest difference between professional camcorders and consumer camcorders is their ability to perform at low light levels. With proper lighting, however, it may be difficult for uninitiated viewers to differentiate between shots taken with an expensive studio-grade video camera and an inexpensive camcorder. Using a simple floodlight kit, or even just being sure that daylight illuminates the room, can improve your image. Onboard battery lights for camcorders can be useful, but only in conditions where the light acts as a "fill light" to illuminate the details of a subject's face. As in photography, good lighting techniques separate amateurs from professionals in video shoots.

Illustrated in Figure 5.6 is a screen from the Lighting Lab. The standard lighting arrangement of a studio is displayed with fill, key, rim, and background lights. Changing any of these lights can make a dramatic difference in the shot. This project originally used a QuickTime container of several hundred single-frame images of the model as she is lighted by every permutation of lamp and intensity; clicking a light switch instantly shows the effect of that combination. If you are not convinced that lighting is critical to the success of a photo or video shoot, it will become immediately clear with this exercise!

**Figure 5.6: Good Lightning is Essential for Video Quality Results**



Source: Making it work by Tay Vaughan

**5.6.4 Chroma Keys**

Chroma keys allow you to choose a colour or range of colours that become transparent, allowing the video image to be seen "through" the computer image. This is the technology used by a newscast's weather person, who is shot against a blue background that is made invisible when merged with the electronically generated image of the weather map. The weatherman controls the computer part of the display with a small handheld controller.



*Did u know?* A useful tool easily implemented in most digital video editing applications is blue screen, green screen, Ultimatte, or Chroma key editing.

When Captain Picard of Star Trek fame walks on the surface of the moon, it is likely that he is actually walking on a studio set in front of a screen or wall painted blue. Actually placing Picard on the moon was, no doubt, beyond the budget of the shoot, but it could be faked using blue screen techniques. After shooting the video of Picard's walk against a blue background and shooting another video consisting of the desired background moonscape, the two videos were mixed together: wherever there was blue in the Picard shot, it was replaced by the background image, frame by frame.

Blue screen is a popular technique for making multimedia titles because expensive sets are not required. Incredible backgrounds can be generated using 3-D modelling and graphic software, and one or more actors, vehicles, or other objects can be neatly layered onto that background. Video editing applications provide the tools for this. When you are shooting blue screen, be sure that the lighting of the screen is absolutely even; fluctuations in intensity will make this "key" appear choppy or broken. Shooting in daylight, and letting the sun illuminate the screen, will mitigate this problem. Also be careful about "colour spill." If your actors stand too close to the screen, the coloured light reflecting off the screen will spill onto them, and parts of their body will key out. While adjustments in most applications can compensate for this, the adjustments are limited.



*Caution* Beware of fine detail, such as hair or smoke, that wisps over the screen; this does not key well.

### 5.6.5 Composition

The general rules for shooting quality video for broadcast use also apply to multimedia. When shooting video for playback in a small window, it is best to avoid wide panoramic shots, as the sweeping majesty will be lost. Use close-ups and medium shots, head-and-shoulders or even tighter. Depending upon the compression algorithm used (see the discussion on video codecs earlier in the unit), consider also the amount of motion in the shot: the more a scene changes from frame to frame, the more "delta" information needs to be transferred from the computer's memory to the screen. Keep the camera still instead of panning and zooming; let the subject add the motion to your shot, walking, turning, talking.

***Beware of excessive backlighting:*** Shooting with a window or a bright sky in the background—is a common error in amateur video production. Many cameras can be set to automatically compensate for backlighting. If you adjust for this, the background may be "blown out" (so bright the video signal peaks), but at least the foreground image you're focusing on will be visible. Of course, the best choice in this situation is to light the foreground.

Non-professional cameras are set to always adjust the iris (the opening in the lens) to keep the image's overall exposure at a constant level. When you go from a dark to light setting the camera will adjust, and you can often see this shift. Pro cameras allow the iris setting to be locked down to avoid this.

In different situations, white may not be white, depending on the colour temperature (warmth or coolness) of the light source. White balance corrects for bluish, orange, or greenish colour casts resulting from an uneven distribution of colours in the spectrum your eye tells you is white, but your less forgiving digital camera says is not quite white. Many cameras automatically set white balance with best guesses, but they also offer adjustable settings for daylight, shady, cloudy, tungsten, and fluorescent lighting conditions. Try to get the white balance correct when shooting; then you won't be spending time with your editing software to remove the greenish tinge from your client's white wedding dress.

## 5.7 Video Editing

Video editing is the process of manipulating and rearranging video shots to create a new work. Editing is usually considered to be one part of the post production process. Other post-production tasks include titling, colour correction, sound mixing, etc. Many people use the term editing to describe all their post-production work, especially in nonprofessional situations. Whether or not you choose to be picky about terminology is up to you. The term video editing can refer to:

- Linear video editing, using video tape
- Non-linear editing system (NLE), using computers with video editing software

### 5.7.1 Linear Video Editing

Linear video editing is a video editing post-production process of selecting, arranging and modifying images and sound in a predetermined, ordered sequence. Regardless of whether it was captured by a video camera, tapeless camcorder, or recorded in a television studio on a video tape recorder (VTR) the content must be accessed sequentially. For the most part video editing software has replaced linear editing.

Until the advent of computer-based random access non-linear editing systems (NLE) in the early 1990s “linear video editing” was simply called “video editing”.

Video editing reached its full potential in the late 1970s when computer-controlled minicomputer edit controllers along with communications protocols were developed, which could orchestrate an edit based on an EDL, using timecode to synchronize multiple tape machines and auxiliary devices using a 9-Pin Protocol. The most popular and widely used computer edit systems came from Sony, Ampex and the venerable CMX. Systems such as these were expensive, especially when considering auxiliary equipment like VTR, video switchers and character generators (CG) and were usually limited to high-end post-production facilities.

Jack Calaway of Calaway Engineering was the first to produce a lower-cost, PC-based, “CMX-style” linear editing system which greatly expanded the use of linear editing systems throughout the post-production industry. Following suit, other companies, including EMC and Strassner Editing Systems, came out with equally useful competing editing products.

### 5.7.2 Non-linear Editing (NLE)

Top-of-the-line non-linear editing (NLE) software includes Adobe’s Premiere, Apple’s Final Cut, and Avid’s Media Composer, the “A Team” of professional video editors. These are feature-packed and expensive packages designed to work hand-in-hand with fast and powerful computers (six gigabytes of RAM recommended) and dedicated file servers. Many hours of training and many days of experience are needed before users become proficient.

Table 5.1: Free Video Editing Software

Name	Platform	Download Address
Avidemux	Windows/Mac/BSD/Linux	<a href="http://www.avidemux.org">www.avidemux.org</a>
Cinelerra	Linux/Mac	<a href="http://www.heroinewarrior.com/cinelerra.php">www.heroinewarrior.com/cinelerra.php</a>
iMovie	Mac	<a href="http://www.apple.com/ilife/imovie">www.apple.com/ilife/imovie</a>
Kdenlive	Linux/BSD/Mac	<a href="http://www.kdenlive.org">www.kdenlive.org</a>

Contd....



## Notes

Kino	Linux/BSD	<a href="http://kinodv.org">http://kinodv.org</a>
LiVES	Linux/BSD/Mac	<a href="http://lives.sourceforge.net">http://lives.sourceforge.net</a>
OpenShot	Linux	<a href="http://www.openshotvideo.com">www.openshotvideo.com</a>
Pinnacle	Videospin Windows	<a href="http://www.videospin.com/Redesign">www.videospin.com/Redesign</a>
PiTiVi	Linux	<a href="http://www.pitivi.org">www.pitivi.org</a>
VideoLab	Windows	<a href="http://www.mitov.com/html/videolab.html">www.mitov.com/html/videolab.html</a>
VideoThang	TM Windows	<a href="http://www.videothang.com">www.videothang.com</a>
VirtualDub	Windows	<a href="http://www.virtualdub.org">www.virtualdub.org</a>
Windows Live	Movie Maker Windows	<a href="http://explore.live.com/windows-live-movie-maker">http://explore.live.com/windows-live-movie-maker</a>

If your project involves simple cutting and editing of footage, with a few transitions and titles thrown in, then you may be satisfied with simpler software such as Microsoft's Windows Live Movie Maker (see Figure 5.7) or Apple's iMovie for Macs (see Figure 5.8) that come free with the operating system. Table 5.1 contains a list of free video editing software applications to choose from.

**Figure 5.7: Windows Live Movie Maker comes free with Windows and can edit photos and videos, add special effects, and make DVDs and files for the Web.**



Source: <http://origin.arstechnica.com/images/windows7/Windows%20Live%20Movie%20Maker.png>

Notes

Figure 5.8: iMovie is a robust video editor that comes free with Macintosh computers and provides full libraries of title templates, video effects, and transitions

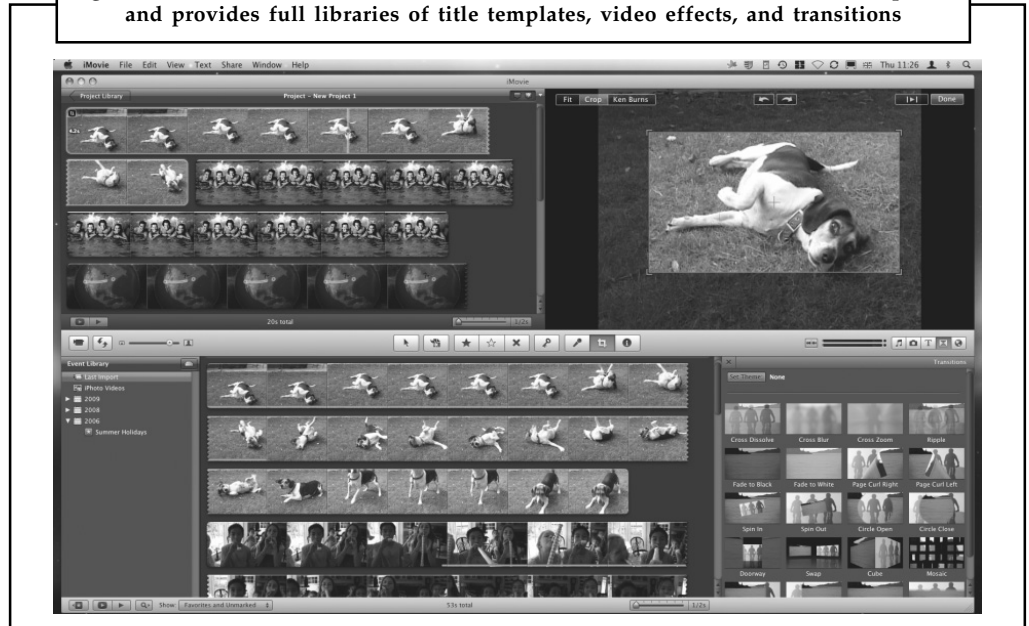

Source: <http://www.icreatemagazine.com/wp-content/uploads/2009/12/Crop-2.png>

Figure 5.9: Titles and text are often used to introduce a video and its content

**Adding titles in iMovie**  
Pick the right theme for your project

- The Cantina Band**  
 Music is incredibly important in *Star Wars*, and it should be just as important in your movie. If you have a copy of the *Star Wars* theme, drag it into the Project Editor for a more authentic feel.
- Luke, I am your father**  
 Make sure you have videos that work well with the theme you're using. The boy in this clip is actually quoting *Star Wars*, but sunny holiday videos may not always work perfectly, for example.

**Knowledge base**

- Star Wars styling**  
 The best way to mimic the style of the *Star Wars* film franchise is to go back and watch one (or all) of the films again. There are some easy tricks that you can add to your movie, like the transitions that wipe across the screen. Adding some great landscape shots is another of George Lucas' favourite techniques, and it's simple to replicate at home.
- It's a trap!**  
 Don't fall into the trap of writing pages of introductory scrolling text; *Star Wars* was a complex series, but you should make sure it's short to keep people interested.
- That's no moon...**  
 iMovie isn't going to be able to add all the special effects of a big-budget film, but if you want to recreate lightsaber battles you can try an excellent app called SaberFX.

Source: <http://www.icreatemagazine.com/wp-content/uploads/2013/01/annotated2.png>

Remember not to edit and re-edit and re-edit again. The video codecs used are lossy, so each time you finalize a file, it will be less true than the original material—this is called generation loss. Because NLE software works with EDLs (edit decision lists) based upon the raw source video, be sure you have sufficient disk space to store your original footage.



*Task* Locate three web sites that include video clips. What format are they served in? Examine the HTML source code to discover what method of video delivery is used. Make a note of your findings.

Notes

## Self Assessment

Fill in the blanks:

1. Avid's Media Composer is a ..... editing software.
2. EDTV stands for Enhanced ..... Television Systems.
3. ISDB is maintained by the Japanese organization .....
4. .... is the name of an ISDB-T service for reception on cell phones, laptop computers and vehicles.
5. SECAM (Séquentiel Couleur avec Mémoire, French for "sequential colour with memory") is an ..... television system.

## 5.8 Optimizing Video Files for CD-ROM

The CD-ROMs provide an excellent distribution medium for computer-based video, because they are inexpensive to mass produce, and they can store great quantities of information. The CD-ROM players offer slow data transfer rates, but adequate video transfer can be achieved by taking care to properly prepare your digital video files. Without great care, these digital files may display poorly in low-bandwidth/high-compression environments:

1. Limit the amount of synchronization required between the video and audio. With Microsoft's AVI file, the audio and video data are already interleaved, so this is not a necessity, but with QuickTime files, you should "flatten" your movie. Flattening means that you interleave the audio and video segments together.
2. Use regularly spaced key frames, 10–15 frames apart, and temporal compression can correct for seek time delays. Seek time is how long it takes the CD-ROM player to locate specific data on the CD-ROM disc. Even fast 56x drives must spin up, causing some delay (and occasionally substantial noise).
3. The size of the video window and the frame rate you specify dramatically affect performance. In QuickTime, 20 frames per second played in a 160 × 120-pixel window is equivalent to playing 10 frames per second in a 320 × 240 window. The more data that has to be decompressed and transferred from the CD-ROM to the screen, the slower the playback.
4. Although interleaving CD-quality audio into your video production will theoretically yield the highest-quality sound, the volume of data required may be too great to transfer from the CD-ROM in real-time. Try a lower sampling rate and sample size to reduce the quantity of audio data.
5. The software compression algorithm you specify will make a dramatic difference in performance. The Sorenson algorithm or codec, available within both AVI and QuickTime, is optimized for CD-ROM playback. But take care: it can take many hours of computation to compress just a few minutes of digital video.
6. Defragment your files before burning the master.

Notes

7. If you are working with QuickTime, consider using a specialized application such as Media Cleaner Pro to automatically optimize your digital video file for playback from CD-ROM.

## **5.9 Digital Display Standards**

Digital display standards are often a combination of aspect ratio, display resolution, colour depth, and refresh rate.

### **5.9.1 Monochrome Display Adapter (MDA)**

The Monochrome Display Adapter (MDA, also MDA card, Monochrome Display and Printer Adapter, MDPA) introduced in 1981 was IBM's standard video display card and computer display standard for the PC. The MDA did not have any pixel-addressable graphics modes. It had only a single monochrome text mode (PC video mode 7), which could display 80 columns by 25 lines of high resolution text characters or symbols useful for drawing forms.

The MDA featured the following character display attributes: invisible, underline, normal, bright (bold), reverse video, and blinking; some of these attributes could be combined, so that e.g., bright, underlined text could be produced.

### **5.9.2 Hercules Graphics Card**

The Hercules Graphics Card (HGC) was a computer graphics controller made by Hercules Computer Technology, Inc. which, through its popularity, became a widely supported display standard. It was common on IBM PC compatibles connected to a monochrome monitor (green, amber, or page white). It supported one high resolution text mode and a single graphics mode.

Its provision of an MDA compatible high quality text mode in combination with a (for its time) high resolution graphics mode (as well as aggressive pricing) made the Hercules card extraordinarily popular in the early days of the PC. The existence of CGA emulation drivers/TSRs, which allowed Hercules users to run programs written for the CGA card's standard graphics modes (albeit only in monochrome, without actual colour), may also have been a contributing factor to its success. Programming for the Hercules card's native graphics mode was somewhat hindered by a lack of BIOS support and standardization from IBM — after all, the HGC was a competing technology. Popular IBM PC programs at the time (such as Lotus 1-2-3 spreadsheet and Autocad computer-aided drafting) came with their own drivers to allow use of the Hercules graphics mode.

Long after its prime, the Hercules card continued to be popular for dual-monitor setups alongside another (colour) graphics adaptor. Certain software detected the HGC and used the monochrome display for extra data display while running the application on the other screen.



*Example:* A CAD work area would be displayed on the main (non-Hercules driven) screen and a list of drawing commands would be shown on the HGC driven monochrome screen. Some software debuggers could take advantage of an HGC to run the main program on the colour monitor and the debugger on the HGC.



*Did u know?* Van Suwannukul, founder of Hercules Computer Technology developed the Hercules in 1982 so that he could work on his doctoral thesis on an IBM PC using the Thai alphabet (his native language).

### 5.9.3 Colour Graphics Adapter (CGA)

Notes

The Colour Graphics Adapter (CGA), originally also called the Colour/Graphics Adapter or IBM Colour/Graphics Monitor Adapter, introduced in 1981, was IBM's first colour graphics card, and the first colour computer display standard for the IBM PC.

The standard IBM CGA graphics card was equipped with 16 kilobytes of video memory, and could be connected either to a NTSC-compatible monitor or television via an RCA connector for composite video, or to a dedicated 4-bit "RGBI" interface CRT monitor, such as the IBM 5153 colour display.

Built around the Motorola MC6845 display controller, the CGA card featured several graphics and text modes. The highest display resolution of any mode was 640×200, and the highest colour depth supported was 4-bit (16 colours).

### 5.9.4 Enhanced Graphics Adapter (EGA)

The Enhanced Graphics Adapter (EGA) is an IBM PC computer display standard specification which is between CGA and VGA in terms of colour and space resolution. Introduced in September 1984 by IBM shortly after (but not exclusively for) its new PC/AT, EGA produces a display of 16 simultaneous colours from a palette of 64 at a resolution of up to 640×350 pixels. The EGA card includes a 16 kb ROM to extend the system BIOS for additional graphics functions, and includes the Motorola MC6845 video address generator as used in the CGA.

### 5.9.5 Video Graphics Array (VGA)

Video Graphics Array (VGA) refers specifically to the display hardware first introduced with the IBM PS/2 line of computers in 1987, but through its widespread adoption has also come to mean either an analogue computer display standard, the 15-pin D-sub miniature VGA connector or the 640×480 resolution itself. While this resolution was superseded in the personal computer market in the 1990s, mobile devices have only caught up in the last few years.

VGA was the last graphical standard introduced by IBM that the majority of PC clone manufacturers conformed to, making it today (as of 2010) the lowest common denominator that almost all post-1990 PC graphics hardware can be expected to implement.



*Example:* The Microsoft Windows splash screen, in versions prior to Windows Vista, appears while the machine is still operating in VGA mode, which is the reason that this screen always appears in reduced resolution and colour depth. Windows Vista and newer versions can make use of the VESA BIOS Extension support of newer graphics hardware to show their splash screen in a higher resolution than VGA allows.

VGA was officially followed by IBM's Extended Graphics Array (XGA) standard, but it was effectively superseded by numerous slightly different extensions to VGA made by clone manufacturers that came to be known collectively as Super VGA.

### 5.9.6 Super VGA (SVGA)

A standard for programming Super VGA modes was defined by VESA in 1989. In that first version, it defined support for (but did not require) a maximum resolution of 800 × 600 4-bit pixels. Each pixel could therefore be any of 16 different colours. It was quickly extended to 1024 × 768 8-bit pixels, and well beyond that in the following years.

**Notes**

Although the number of colours is defined in the VBE specification, this is irrelevant when referring to Super VGA monitors as (in contrast to the old CGA and EGA standards) the interface between the video card and the VGA or Super VGA monitor uses simple analogue voltages to indicate the desired colour. In consequence, so far as the monitor is concerned, there is no theoretical limit to the number of different colours that can be displayed. Note that this applies to any VGA or Super VGA monitor.

While the output of a VGA or Super VGA video card is analogue, the internal calculations the card performs in order to arrive at these output voltages are entirely digital.

**Self Assessment**

Fill in the blanks:

- 6. .... defined the standard for programming Super VGA modes.
- 7. Enhanced Graphics Adapter (EGA) released by IBM in .....
- 8. .... developed the Hercules Graphics Card (HGC).
- 9. Video Graphics Array (VGA) introduced in the market in .....
- 10. .... did not have any pixel-addressable graphics modes.



*Case Study*

**Jackson uses Engaging Online Video to More Effectively Educate Financial Advisors on Investment Choices**

**A Success Story**

**Challenge**

Jackson National Life Distributors is a leading distributor of third-party investments through their variable annuity lineup. The company leverages hundreds of wholesalers that network with thousands of financial advisors who then market these investment options to existing and potential clients. These investment professionals need to be educated and updated on the nearly 100 investments within Jackson's lineup so they can clearly communicate the distinct value of each investment option to their clients.

**Solution**

Jackson is working with its fund partners and Thomson Reuters to develop an investment education platform featuring a library of on-demand video webcasts for each money manager. Archived in a secure online portal, advisors and wholesalers can access these webcasts at their convenience to learn about each manager and its portfolio offered through Jackson. Leveraging video to deliver this content provides greater clarity in the key messages conveyed to Jackson's network so they can more effectively engage clients.

**Powering Advisor Communications With Online Video**

While many financial services firms are just beginning to integrate multimedia into their communication strategy to improve audience engagement, some have fully embraced this medium and are already looking for ways to build upon years of success.

*Contd....*

## Notes

"We have been using multimedia to educate advisors and wholesalers on our products for years," said Luis Gomez, Vice President of Marketing Strategy at Jackson National Life Distributors, an industry leader in variable, fixed and fixed index annuities, also offering life insurance and institutional products. "If we relied solely on e-mail or mailings to deliver those messages it just would not be as effective. We are always looking for innovative ways to differentiate ourselves. Expanding the use of video was the next step in the evolution of our marketing program."

After discovering Flash-based presentations and video e-mail were more effective than text-based materials in educating advisors and wholesalers about complex products, Gomez sought to develop a library of online videos to provide an even richer experience. "We found that text-based communications led to a lot of confusion as they left room for interpretation and were not very dynamic. Video not only helps in simplifying products which are often complex, but it also communicates body language and tone so advisors and wholesalers can really understand how to deliver the message."

#### **Online Video as the Centerpiece to Jackson's Investment Platform Lineup**

The process of building the video library starts with Gomez asking fund partners to create video overviews for selecting variable annuity options. Once completed, the content is returned to Jackson's compliance group for review. After feedback is exchanged and the videos are approved, Thomson Reuters uploads the files into a completely customized on-demand video Notes webcast player. Featuring both Jackson's and the fund's branding, the player includes links to other fund videos in the series as well as additional resources. Viewers can access the videos in high-resolution 800 k Windows Media or Flash streams twenty-four hours a day, seven days a week using any modern Web browser and operating system.

"At Jackson we promote the freedom\* to choose from a variety of investment options, and we want to represent that diversity in this video library," said Gomez. "We're working toward creating an online investment repository featuring video webcasts from all twenty fund partners along with supporting resources to enhance our communications program and more effectively market our products." Gomez added that the unique approach each money manager takes toward crafting its videos makes the resource even more valuable. "The differences really come out in the video, both in the investment options themselves and in the way they are positioned by our partners," said Gomez. "At the same time, we're presenting the videos in a consistent way through the webcast solution Thomson Reuters designed for us. It's a seamless experience from the viewer's perspective."

#### **Measuring the Success of Online Video**

Gomez will consider both qualitative and quantitative metrics in gauging the success of the program. "The response we get from advisors and wholesalers is important and their feedback was one of the reasons we have expanded the use of video," said Gomez. "In addition, we will review the analytics Thomson Reuters provides for each of the webcasts-such as visits and viewing time-to help us monitor how well the content is resonating with our audiences."

#### **Questions:**

1. What do you think about the above success story?
2. Write a note on video libraries.

*Source:* [http://documents-cdn.mcs.thomsonreuters.com/4fb26df4983a8\\_Thomson-Reuters-Jackson-MMS-case-study.pdf](http://documents-cdn.mcs.thomsonreuters.com/4fb26df4983a8_Thomson-Reuters-Jackson-MMS-case-study.pdf)

Notes

### 5.10 Summary

- Video places the highest performance demand on any computer system.
- A charge-coupled device (CCD) converts the light that has been reflected from an object through the camera's lens.
- Four broadcast and video standards and recording formats are commonly in use around the world: NTSC, PAL, SECAM, and HDTV.
- HDTV provides high resolution in a 16:9 aspect ratio.
- Flat screen displays are all-digital, using either liquid crystal display (LCD) or plasma technologies, and have supplanted CRTs for computer use.
- Always shoot using a steady shooting platform.
- Storyboards are a useful exercise when planning a shoot.
- Good, even lighting is extremely important.
- Most editing is now being done on computers using non-linear editing (NLE) software such as Avid, Premiere, and Final Cut.

### 5.11 Keywords

**Camcorder:** A portable combined video camera and video recorder.

**Flash memory:** An electronic non-volatile computer storage device that can be electrically erased and reprogrammed.

**Hybrid:** A thing made by combining two different elements.

**John F. Kennedy:** The 35th President of the United States, serving from 1961 until his death in 1963.

**RAID:** Redundant Array of Independent Disks is a category of disk drives that employ two or more drives in combination for fault tolerance and performance.

**SDTV:** Standard Definition Television is a television system that uses a resolution that is not considered to be either high-definition television (HDTV 720p, 1080i, and 1080p) or enhanced-definition television (EDTV 480p).

### 5.12 Review Questions

1. Define video editing. Write about two types of video editing techniques.
2. Elucidate how vide works in detail.
3. Differentiate between NTSC and PAL.
4. Explain VGA and Super VGA.
5. Explain the process of recording videos.
6. How are video files optimized for CD-ROM?
7. Write a note on the following:
  - (a) NTSC
  - (b) PAL



- (c) SECAM  
 (d) ATSC  
 (e) DTV  
 (f) HDTV
8. What are digital display standards? Discuss about any two of them.  
 9. Write in detail about analogue video.  
 10. What do you mean by digital video standards? Explain with examples.

### Answers: Self Assessment

- |                   |                                |
|-------------------|--------------------------------|
| 1. Non-linear     | 2. Definition                  |
| 3. ARIB           | 4. 1seg                        |
| 5. Analogue       | 6. VESA in 1989                |
| 7. September 1984 | 8. Van Suwannukul              |
| 9. In 1987        | 10. Monochrome Display Adapter |

### 5.13 Further Readings



#### Books

Frederick P. Brooks, Jr., Kenan Professor of Computer Science, *The Mythical Man-Month: Essays in Software Engineering*, University of North Carolina at Chapel Hill.

K. Andleigh and K. Thakkar, *Multimedia System Design*, PHI, PTR.

Steve Rimmer (2000), *Advanced Multimedia Programming*, MHI.

Tay Vaughan, *Multimedia Making it work*, Seventh Edition, Tata McGraw-Hill Education Private Ltd.



#### Online links

<http://nora.lis.uiuc.edu:3030/companion/view?docId=blackwell/9781405103213/9781405103213.xml&doc.view=print&chunk.id=ss1-2-10&toc.depth=1&toc.id=0>

[http://users.mct.open.ac.uk/yr258/papers/Rogers\\_Scaife98.pdf](http://users.mct.open.ac.uk/yr258/papers/Rogers_Scaife98.pdf)

<http://www.icheg.org/icheg-game-history/timeline/>

<http://www.ict.griffith.edu.au/teaching/1611ICT/mm1lectures/111/Writing%20For%20Multimedia%20Great%20Moments%20In%20Multimedia%20History.htm>

[http://www.washington.edu/doit/Brochures/Technology/vid\\_sensory.html](http://www.washington.edu/doit/Brochures/Technology/vid_sensory.html)

## Unit 6: Hardware

### CONTENTS

Objectives

Introduction

6.1 Macintosh versus Windows

6.2 Connections

6.2.1 Integrated Drive Electronics (IDEs)

6.2.2 Small Computer System Interface (SCSI)

6.2.3 Enhanced Integrated Drive Electronics (EIDEs)

6.2.4 Analogue Telephone Adapter (ATA)

6.2.5 Universal Serial Bus (USB)

6.2.6 FireWire

6.3 Storage Devices

6.3.1 Random Access Memory (RAM)

6.3.2 Read-only Memory (ROM)

6.3.3 Floppy and Hard Disks

6.3.4 Zip, Jaz, SyQuest and Optical Storage Devices

6.3.5 Digital Versatile Disc (DVD)

6.3.6 CD-ROM

6.3.7 CD-ROM Players

6.3.8 CD Recorders

6.3.9 Videodisc Players

6.4 Input Devices

6.4.1 Keyboard Entry

6.4.2 Pointing Devices

6.5 Output Devices

6.5.1 Sound Recording Equipment

6.5.2 Speakers

6.5.3 Monitors

6.5.4 Video Recording Equipment

6.5.5 Projectors

6.5.6 Printers

6.6 Summary

6.7 Keywords

6.8 Review Questions

6.9 Further Readings

## Objectives

Notes

After studying this unit, you will be able to:

- Understand Macintosh versus Windows
- Explain different types of connections
- Describe storage devices
- Understand different types of input devices
- Explain output devices

## Introduction

In producing a multimedia program, we need to: Gather data for the 5 basic elements of multimedia: text, animation, graphics, video and audio by using hardware. To edit the elements, we need special editing software. The most common hardware used are scanner, video camera, camera for still photos, audio device, and video capture device. Each of these hardware has its functions and characteristics. Knowing the functions of the hardware and how to use them are important. This will enable us to integrate the basic elements of multimedia into a program.

A few years ago, purchasing a multimedia computer was quite complicated, but because of the tremendous growth of multimedia applications, most computers that you buy today are already designed to run multimedia applications. If you are interested in developing multimedia applications, however, you should consider a more powerful computer. If your computer is too slow, productivity will be lost; and in today's fast-paced technological society, you need a fast computer to keep up.

Effectively developing and delivering multimedia applications requires a more powerful personal computer than one used to write a letter, prepare a budget, or answer e-mail. Because personal computers are becoming more and more powerful, most of those purchased today have built-in multimedia capabilities that allow you to deliver and display multimedia applications. However, if creation of high-end multimedia applications is your goal, you will definitely want to consider certain specifications that have been established specifically for multimedia.

### 6.1 Macintosh versus Windows

The two types of desktop computer used for multimedia development are the Apple Mac and the Microsoft Windows based personal computer or PC. Both platforms share these common components as do most types of computer:

- **Processor:** The processor or central processing unit is the key component and controls the rest of the computer and executes programs.
- **Cache:** Cache is a small amount of very high speed memory built into the processor for doing immediate calculations.
- **RAM memory:** RAM (random access memory) is the working memory where the current application program resides.
- **System bus:** The system bus connects all the necessary devices to the processor. There are other buses that connect to the system bus like SCSI for hard drives.
- **Motherboard:** The processor, cache, RAM and system bus all reside on a main printed circuit board called the motherboard.

Notes

- **Operating system:** The operating system manages the loading and unloading of applications and files and the communication with other peripheral devices like printers.
- **Storage devices:** Application programs and working files are saved longer term on different kinds of storage device. Storage devices include hard disk drives, CD-ROMs and floppy drives.
- **Input/output devices:** Connected to the system bus are a number of other devices that control the other essential components of a desk top computer including the monitor, mouse, keyboard, speakers, printer, scanner.
- **Expansion bus:** Most desktops should include 'slots' into which other non-standard devices can be installed.

The latest specification Macs and PCs are capable of running the application tools necessary for developing standard multimedia applications. The standard applications are image, sound and video editing, animation and multimedia integration. Comparisons of the performance of the latest generation of PCs and Macs are hotly contested but in general they are now roughly the same with each type of computer performing better on some tasks than others. Apple Macs have, in the past, been more associated with the multimedia industry, however PCs are increasingly being used since they are now capable of undertaking the same processor intensive tasks like video compression equally well. High specification computers are required to undertake some of the tasks required in multimedia development.

Today's computer users live in a veritable golden age when it comes to choosing computing devices. In truth, there's no clear winner in the Mac vs. PC contest. Instead, both devices have significant developments. Both platforms now can come equipped with Intel® Core™ processors that result in impressive performance. In addition, both Mac and PC demonstrate increased memory; larger hard drive space; better stability and more availability than four years ago. However, differences remain: the PC and Ultrabook™ are widely available with touchscreens, but Apple has yet to release a Mac or MacBook\* with integrated touchscreen technology. Retina display, which greatly reduces glare and reflection, is a standard feature on the new iMac\*, but is less common on PCs.

**Compatibility:** While the main operating system for Apple is OSX\*, and PCs operate on Microsoft Windows\*, only Macs have the capability to run both. Naturally, both systems continue to develop faster and more powerful versions of these operating systems that are increasingly user-friendly and more compatible with handheld devices.

And though the PC tends to dominate in the workplace, many software programs for professional use—including Microsoft Office\* and the Adobe Creative Suite\*—have versions for both operating systems. When it comes to apps for leisure purposes, it's important to realize they're not only for handheld devices. There are numerous web-based applications that replace the necessity for installing software on your computer by letting you perform all of the functions in the web browser. This may sound complicated, but you're probably familiar with some of them already. Think about Flickr\* for online photo managing and sharing, Pinterest\* for online scrapbooking, YouTube\* apps for streaming your favourite videos, and Qusic\*, which alerts you to new releases from your favourite musical artists.

**Reliability:** When it comes to reliability, the Mac vs. PC debate has had some interesting developments of late. Though the majority of PC users know their devices are vulnerable to malware and viruses, Mac users this past year have certainly awoken to the fact that Macs are also vulnerable to sophisticated attacks. Ultimately, both PC and Mac users are safer after installing up-to-date antivirus software designed to protect their devices from malicious hits.

Even when it comes to repairs, both operating systems have made great strides. Though it's still advised to take a broken Mac to an Apple Genius Bar\* in an authorized Apple dealership, there

are more locations than there were a few years ago. PC users enjoy a broader range of choices, from their local electronics dealer to a repair centre at a major department store, though it remains their own responsibility to choose a repair service that's up to their PC manufacturer's standards.

Since PCs and Macs hit the market, the debate has existed over which is best. Depending upon who you're talking to, the PC vs. Mac debate is often even hotter than politics or religion. While you have many who are die-hard Microsoft PC users, another group exists that is just as dedicated to Apple's Mac\*. A final group exists in the undecided computer category.

**Cost:** For many users, cost is key. You want to get the absolute most for your money. In years past, PCs dominated the budget-friendly market, with Macs ranging anywhere from \$100 to \$500 more than a comparable PC. Now this price gap has lessened significantly. However, you will notice a few key features that Macs tend to lack in order to provide a lower price: memory and hard drive space.

**Memory:** Most PCs have anywhere from 2 GB to 8 GB of RAM in laptops and desktops, while Macs usually have only 1 GB to 4 GB. Keep in mind, this is for standard models, not custom orders.

**Hard Drive Space:** Macs typically have smaller hard drives than PCs. This could be because some Mac files and applications are slightly smaller than their PC counterparts. On average, you will still see price gaps of several hundred dollars between comparable Macs and PCs. For computing on a budget, PCs win.

There are a few things to take into consideration that may actually make Macs more cost effective: stability and compatibility.

**Stability:** In years past, PCs were known to crash, and users would get the "blue screen," but Microsoft has made their operating systems more reliable in recent years. On the other hand, Mac hardware and software have tended to be stable, and crashes occur infrequently.

**Compatibility:** Unlike with a PC, a Mac can also run Windows. If you want to have a combination Mac and PC, a Mac is your best option.

**Availability:** Macs are exclusive to Apple. This means for the most part, prices and features are the same no matter where you shop. This limits Mac availability. However, with the new Apple stores, it's even easier to buy Macs and Mac accessories. Any upgrades or repairs can only be done by an authorized Apple support center.

PCs, on the other hand, are available from a wide range of retailers and manufacturers. This means more customization, a wider price range for all budgets, repairs, and upgrades available at most electronics retailers and manufacturers. It also makes it easier for the home user to perform upgrades and repairs themselves as parts are easy to find.

**Web Design:** 95 per cent of the people surfing the Web use Windows on PCs. If you want to be able to design in an atmosphere where you see pretty much what that 95 per cent sees, then Windows just plain makes sense. Secondly, though many technologies are available for the Mac, Windows technology is not and much of the Web uses this technology. If you want to take advantage of .NET technology or ASP, it is just way easier to implement from a Windows platform.

**Software:** The final Mac vs. PC comparison comes down to software. For the most part, the two are neck and neck. Microsoft has even released Microsoft Office specifically for Mac, proving Apple and Microsoft can get along. All and all, Macs are more software compatible as PCs only support Windows friendly software. Both systems support most open-source software. Software for both systems is user friendly and easy to learn.

Notes

In the end, the choice comes down to personal preference. Due to price and availability, PCs tend to be the winner, while Macs remain the choice for the more elite or anti-Microsoft computer users.

## 6.2 Connections

Establishing a connection between two multimedia devices is very easy now using a lot of connecting devices. There are many hardware devices which are generally used for making a connection between two or more devices such as cables. Here, we are discussing some interfaces and connecting devices.

### 6.2.1 Integrated Drive Electronics (IDEs)

Computers have three main storage devices – hard drive, floppy drive and CD-ROM drive. These storage devices connect to computers through Integrated Drive Electronics, IDE. Short for Integrated Drive Electronics or IBM Disc Electronics, IDE is more commonly known as ATA or Parallel ATA (PATA) and is a standard interface for IBM compatible hard drives.

IDE is different from the Small Computer Systems Interface (SCSI) and Enhanced Small Device Interface (ESDI) because its controllers are on each drive, meaning the drive can connect directly to the motherboard or controller. IDE and its updated successor, Enhanced IDE (EIDE), are the most common drive interfaces found in IBM compatible computers today. Below, is a picture of the IDE connector on the back of a hard drive, a picture of what an IDE cable looks like, and the IDE channels it connects to on the motherboard.

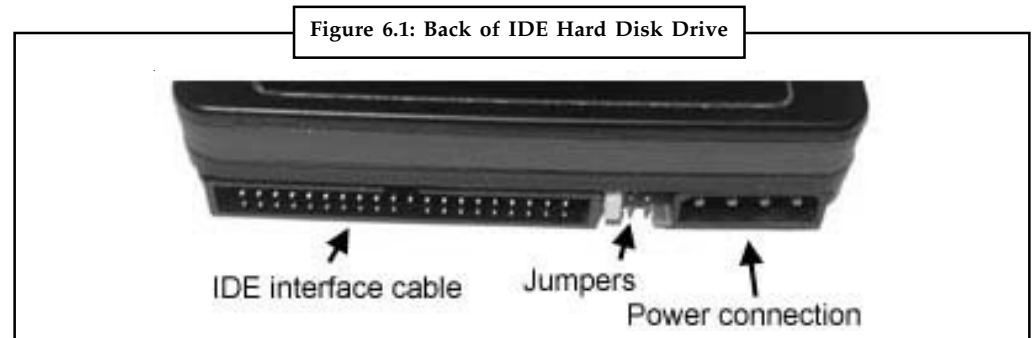

Source: <http://www.computerhope.com/jargon/j/hddjumpers.jpg>

IDE connectors are 40 pins wide, and a single IDE cable can have up to two IDE devices connected to it. One of these devices is designated the “Master” and the other device the “Slave”. Master/Slave status is determined by a jumper – a small cap placed over pins to enable/disable an electrical connection. IDE is the most common and least expensive Hard Drive interface, and it is also commonly used for ZIP drives and CD ROM drives.

### Understanding IDE Terms

IDE has several transfer modes. The fastest, and most recent, is called ATA66'. These drives, when connected to an ATA66-compatible IDE controller, can transfer data at 66.6MB/second. Ultra DMA-33 (UDMA), the predecessor to ATA66, could transfer data at 33.3MB/second. The newer standards, however, can still be used with older controllers that do not support them. They will simply use the best transfer mode they have available (UDMA33 or an earlier one, if applicable.)

## Other IDE Devices

## Notes

While IDE was initially designed to control hard drives, it is now used for CD/DVD/CD-RW drives and ZIP drives as well. Since IDE controllers only control up to two devices, (one master' and one slave'), expansion is difficult if you see yourself adding many devices, such as a CD ROM burner, an internal ZIP drive and additional hard drive. However, many of these devices can be added as external USB devices, so this may not be as big an issue as it sounds if you don't mind external devices.

## Selecting an IDE Hard Drive

For best performance, gamers looking for an IDE hard drive should look for one that supports ATA66. Also be sure to pick up an ATA66 IDE cable, which is just an improved IDE cable to accommodate the higher speed (it will still connect to any standard 40-pin IDE connectors too.) The only limitation to using IDE is limited expansion. Most systems cannot accommodate more than four IDE devices (CDROM, ZIP, Hard Disk). Gamers requiring more might want to consider SCSI.

## IDE and ATA-1

The first version of what is now called the ATA/ATAPI interface was developed by Western Digital under the name Integrated Drive Electronics (IDE). Together with Control Data Corporation (who manufactured the hard drive part) and Compaq Computer (into whose systems these drives would initially go), they developed the connector, the signalling protocols, and so on with the goal of remaining software compatible with the existing ST-506 hard drive interface. The first such drives appeared in Compaq PCs in 1986.

The term Integrated Drive Electronics refers not just to the connector and interface definition, but also to the fact that the drive controller is integrated into the drive, as opposed to a separate controller on or connected to the motherboard. The interface cards used to connect a parallel ATA drive to, for example, a PCI slot are not drive controllers: they are merely bridges between the host bus and the ATA interface. Since the original ATA interface is essentially just a 16-bit ISA bus in disguise, the bridge was especially simple in case of an ATA connector being located on an ISA interface card.

The integrated controller presented the drive to the host computer as an array of 512-byte blocks with a relatively simple command interface. This relieved the mainboard and interface cards in the host computer of the chores of stepping the disk head arm, moving the head arm in and out, and so on, as had to be done with earlier ST-506 and ESDI hard drives. All of these low-level details of the mechanical operation of the drive were now handled by the controller on the drive itself. This also eliminated the need to design a single controller that could handle many different types of drives, since the controller could be unique for the drive. The host need only ask for a particular sector, or block, to be read or written, and either accept the data from the drive or send the data to it.

The interface used by these drives was standardized in 1994 as ANSI standard X3.221-1994, AT Attachment Interface for Disk Drives. After later versions of the standard were developed, this became known as "ATA-1". A short-lived, seldom-used implementation of ATA was created for the IBM XT and similar machines that used the 8-bit version of the ISA bus. It has been referred to as "XTA" or "XT Attachment".

## Notes

## 6.2.2 Small Computer System Interface (SCSI)

Small Computer System Interface is one of the most commonly used interface for disk drives. It is a set of standards for physically connecting and transferring data between computers and peripheral devices. The SCSI standards define commands, protocols and electrical and optical interfaces. SCSI is most commonly used for hard disks and tape drives, but it can connect a wide range of other devices, including scanners and CD drives, although not all controllers can handle all devices.

SCSI was derived from "SASI", the "Shugart Associates System Interface", developed in 1978 and publicly disclosed in 1981. A SASI controller provided a bridge between a hard disk drive's low-level interface and a host computer, which needed to read blocks of data. SASI controller boards were typically the size of a hard disk drive and were usually physically mounted to the drive's chassis. SASI, which was used in mini- and early microcomputers, defined the interface as using a 50-pin flat ribbon connector which was adopted as the SCSI-1 connector. SASI is a fully compliant subset of SCSI-1 so that many, if not all, of the then-existing SASI controllers were SCSI-1 compatible.

Figure 6.2: SCSI Adapter Card

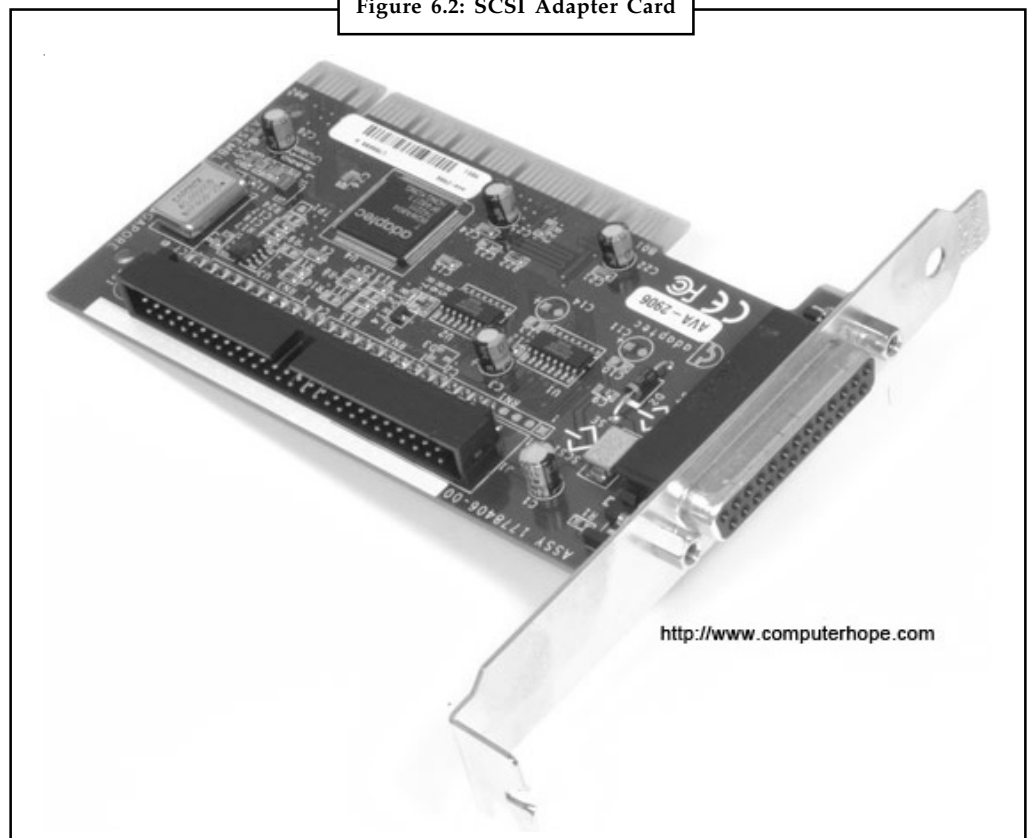

Source: <http://cdn.computerhope.com/scsi.jpg>

SCSI-1 is the original SCSI standard developed back in 1986 as ANSI X3.131-1986. It is capable of transferring up to eight bits a second.

SCSI-2 was approved in 1990, added new features such as Fast and Wide SCSI, and support for additional devices.

SCSI-3 was approved in 1996 as ANSI X3.270-1996.



## Notes

- **Wide SCSI:** Uses a wider cable (168 cable lines to 68 pins) to support 16-bit transfers.
- **Fast SCSI:** Uses an 8-bit bus but doubles the clock rate to support data rates of 10 MB per second.
- **Fast Wide SCSI:** Uses a 16-bit bus and supports data rates of 20 MB per second.
- **Ultra SCSI:** Uses an 8-bit bus and supports data rates of 20 MB per second.
- **SCSI-3:** Uses a 16-bit bus and supports data rates of 40 MB per second. It is also called Ultra Wide SCSI.
- **Ultra2 SCSI:** Uses a 8-bit bus and supports data rates of 40 MB per second.
- **Wide Ultra2 SCSI:** Uses a 16-bit bus and supports data rates of 80 MB per second.
- **Ultra 160 (LVD):** Uses a 32-bit bus and supports data rates of 160 MB per second.



*Did u know?* Larry Boucher is considered to be the “father” of SASI and SCSI due to his pioneering work first at Shugart Associates and then at Adaptec.

Since its standardization in 1986, SCSI has been commonly used in the Amiga, Apple Macintosh and Sun Microsystems computer lines and PC server systems. Recent versions of SCSI – Serial Storage Architecture (SSA), SCSI-over-Fibre Channel Protocol (FCP), Serial Attached SCSI (SAS), Automation/Drive Interface “ Transport Protocol (ADT), and USB Attached SCSI (UAS) – break from the traditional parallel SCSI standards and perform data transfer via serial communications.

## Interfaces

SCSI is available in a variety of interfaces. The first, still very common, was parallel SCSI (now also called SPI), which uses a parallel bus design. As of 2008, SPI is being replaced by Serial Attached SCSI (SAS), which uses a serial design but retains other aspects of the technology. Many other interfaces which do not rely on complete SCSI standards still implement the SCSI command protocol; others (such as iSCSI) drop physical implementation entirely while retaining the SCSI architectural model. iSCSI, for example, uses TCP/IP as a transport mechanism.

Figure 6.3: Single Connector Attachment (SCA-2) connector on Fujitsu MAP3735NC

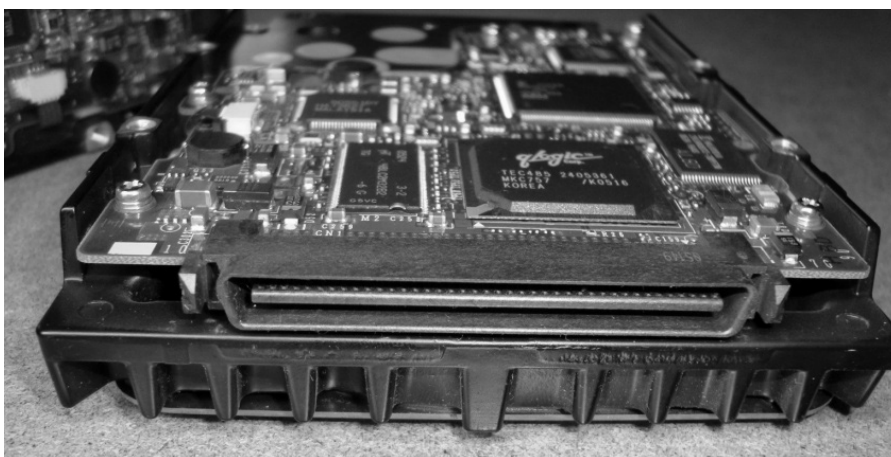

SCSI interfaces have often been included on computers from various manufacturers for use under Microsoft Windows, Mac OS, Unix, Commodore Amiga and Linux operating systems,

**Notes**

either implemented on the motherboard or by the means of plug-in adaptors. With the advent of SAS and SATA drives, provision for SCSI on motherboards is being discontinued. [citation needed] A few companies still market SCSI interfaces for motherboards supporting PCIe and PCI-X.

### **6.2.3 Enhanced Integrated Drive Electronics (EIDEs)**

Stands for “Enhanced Integrated Drive Electronics.” EIDE is an improved version of the IDE drive interface that provides faster data transfer rates than the original standard. While the original IDE drive controllers supported transfer rates of 8.3 Mbps, EIDE can transfer data up to 16.6 Mbps, which is twice as fast.

EIDE’s enhancements to Integrated Drive Electronics make it possible to address a hard disk larger than 528 MB. EIDE also provides faster access to the hard drive, support for direct memory access (DMA), and support for additional drives, including CD-ROM and tape devices. EIDE was adopted as a standard by ANSI in 1994. ANSI calls it Advanced Technology Attachment-2, also referred to as Fast ATA or ATA-2.

While EIDE was the most common drive controller used for many years, it has since been replaced by updated versions of the ATA standard that support Ultra DMA. These include the ATA-4 through ATA-7 standards, which provide data throughput rates from 33 to 133 Mbps. Most modern computers use a completely new standard called “Serial ATA,” or SATA, which supports even faster transfer rates.

### **6.2.4 Analogue Telephone Adapter (ATA)**

An analogue telephone adaptor (ATA) is a device used to connect a standard telephone to a computer or network so that the user can make calls over the Internet. Internet-based long distance calls can be substantially cheaper than calls transmitted over the traditional telephone system, and ATAs are typically cheaper than specialized VoIP phones that connect directly to a computer’s Universal Serial Bus (USB) port.

Whether or not VoIP is cheaper than traditional phone service depends on a number of factors, including the rates charged by the respective service providers and equipment costs. Skype, one VoIP provider, offers free calling locally and between members, and inexpensive long-distance calls to other numbers.

There are several types of analogue telephone adapters. All ATAs create a physical connection between a phone and a computer or a network device; some perform analogue-to-digital conversion and connect directly to a VoIP server, while others use software for either or both of these tasks.

The simplest type of ATA has one or more RJ-11 jacks to plug a telephone (and/or a fax) into and a USB connector that plugs into the user’s computer, laptop, or handheld device. This type of ATA often works in conjunction with some type of software (typically a softphone program). The software acts as an intermediary between the telephone and a VoIP server, digitizing voice data so that it can be transmitted over the Internet.

In an enterprise setting, an ATA usually has multiple telephone jacks and an RJ-45 connection to a 10/100BaseT Ethernet hub or switch, and is used to connect to a local area network (LAN). Such an ATA digitizes voice data, and uses protocols such as H.323 or SIP to communicate directly with a VoIP server so that a softphone is not required. An ATA that connects telephones to a LAN is sometimes called a VoIP gateway. Some Internet telephony service providers, such as Vonage, provide an ATA to their customers as part of the service package.

## Features of an ATA

## Notes

**Ability to support VoIP protocols:** The more protocols one can support, the better it is. SIP and H.323 are supported on all new ATAs today.

**Ports:** An ATA should provide at least one LAN (RJ-45) port and one RJ-11 port, so as to make the interface between the phone network and the VoIP service. Some ATAs even provide additional ports.



*Example:* A RJ-45 port to connect to a computer. You can use this to do phone-to-PC calls.

Some ATA's have USB ports which allow them to more easily connect to computers and other devices.

**Call Switching:** Many people use PSTN and VoIP interchangeably. The call switching features in the ATA allows you to easily switch between these two.

**Standard Service Features:** It is common and practical today to have several service features like Caller ID, Call Waiting, Call Transfer, Call Forwarding etc. A good ATA should support all these.

**3-Way Conferencing:** Many ATA's come with 3-way conferencing support, which allows you to talk to more than one person at the same time. This proves to be very useful especially in a business context.

**Power Failure Tolerance:** The ATA runs on electric power. It normally stops working in case of a power cut. This should not mean that your communication should be completely paralyzed. A good ATA should automatically switch to PSTN line default in case there is a power failure.

**Voice Quality:** ATA manufacturers are sharpening their saws day after day. Some ATAs provide superb hi-fidelity voice quality with enhanced technologies like Digital Signal Processing (DSP).

**Interoperability:** In a company context, an ATA may be part of an already-complex hardware structure. For this reason, a good ATA should be compliant and interoperable to a maximum with other hardware devices.

### 6.2.5 Universal Serial Bus (USB)

Universal Serial Bus (USB) is an industry standard developed in the mid-1990s that defines the cables, connectors and communications protocols used in a bus for connection, communication and power supply between computers and electronic devices.

USB was designed to standardize the connection of computer peripherals (including keyboards, pointing devices, digital cameras, printers, portable media players, disk drives and network adapters) to personal computers, both to communicate and to supply electric power. It has become commonplace on other devices, such as smartphones, PDAs and video game consoles. USB has effectively replaced a variety of earlier interfaces, such as serial and parallel ports, as well as separate power chargers for portable devices.



*Did u know?* As of 2008, approximately six billion USB ports and interfaces were in the global marketplace, and about two billion were being sold each year.

Notes

**USB Cables and Connectors**

Connecting a USB device to a computer is simple—you find the USB connector on the back of your machine and plug the USB connector into it.

If it's a new device, the operating system auto-detects it and asks for the driver disk. If the device has already been installed, the computer activates it and starts talking to it. USB devices can be connected and disconnected at any time.

**Figure 6.4: The Rectangular Socket is a Typical USB Socket**

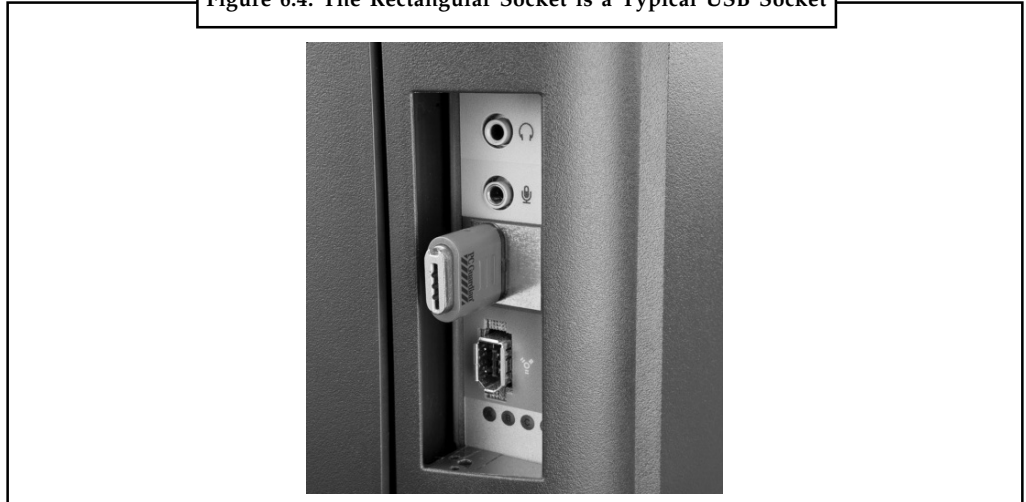

Source: <http://ww1.prweb.com/prfiles/2007/02/08/503833/USBdesktopSPortBlock.jpg>

Many USB devices come with their own built-in cable, and the cable has an “A” connection on it. If not, then the device has a socket on it that accepts a USB “B” connector.

**Figure 6.5: A typical USB connector, called an “A” connection**



Source: <http://en.academic.ru/pictures/enwiki/85/USB-Connector-Standard.jpg>

The USB standard uses “A” and “B” connectors to avoid confusion:

- “A” connectors head “upstream” toward the computer.
- “B” connectors head “downstream” and connect to individual devices.

By using different connectors on the upstream and downstream end, it's impossible to ever get confused—if you connect any USB cable's “B” connector into a device, you know that it'll work. Similarly, you can plug any “A” connector into any “A” socket and know that it'll work.

## The USB Process

## Notes

When the host powers up, it queries all of the devices connected to the bus and assigns each one an address. This process is called enumeration — devices are also enumerated when they connect to the bus. The host also finds out from each device what type of data transfer it wishes to perform:

**Interrupt:** A device like a mouse or a keyboard, which will be sending very little data, would choose the interrupt mode.

**Bulk:** A device like a printer, which receives data in one big packet, uses the bulk transfer mode. A block of data is sent to the printer (in 64-byte chunks) and verified to make sure it's correct.

**Isochronous:** A streaming device (such as speakers) uses the isochronous mode. Data streams between the device and the host in real-time, and there is no error correction.

The host can also send commands or query parameters with control packets.

As devices are enumerated, the host is keeping track of the total bandwidth that all of the isochronous and interrupt devices are requesting. They can consume up to 90 per cent of the 480 Mbps of bandwidth that's available (USB 3.0 increases that speed to 4.8 gigabits per second). After 90 per cent is used up, the host denies access to any other isochronous or interrupt devices. Control packets and packets for bulk transfers use any bandwidth left over (at least 10 per cent).

The Universal Serial Bus divides the available bandwidth into frames, and the host controls the frames. Frames contain 1,500 bytes, and a new frame starts every millisecond.



*Notes* During a frame, isochronous and interrupt devices get a slot so they're guaranteed the bandwidth they need. Bulk and control transfers use whatever space is left.

## USB Features

The Universal Serial Bus has the following features:

- The computer acts as the host.
- Up to 127 devices can connect to the host, either directly or by way of USB hubs.
- Individual USB cables can run as long as 5 meters; with hubs, devices can be up to 30 meters (six cables' worth) away from the host.
- With USB 2.0, the bus has a maximum data rate of 480 megabits per second (10 times the speed of USB 1.0).
- A USB 2.0 cable has two wires for power (+5 volts and ground) and a twisted pair of wires to carry the data. The USB 3.0 standard adds four more wires for data transmission. While USB 2.0 can only send data in one direction at a time (downstream or upstream), USB 3.0 can transmit data in both directions simultaneously.
- On the power wires, the computer can supply up to 500 milliamps of power at 5 volts. A USB 3.0 cable can supply up to 900 milliamps of power.
- Low-power devices (such as mice) can draw their power directly from the bus. High-power devices (such as printers) have their own power supplies and draw minimal power from the bus. Hubs can have their own power supplies to provide power to devices connected to the hub.

**Notes**

- USB devices are hot-swappable, meaning you can plug them into the bus and unplug them any time. A USB 3.0 cable is compatible with USB 2.0 ports — you won't get the same data transfer speed as with a USB 3.0 port but data and power will still transfer through the cable.
- Many USB devices can be put to sleep by the host computer when the computer enters a power-saving mode.

The devices connected to a USB port rely on the cable to carry power and data.

**Wireless USB**

Wireless USB is the wireless extension to USB that combines the speed and security of wired technology with the portability and clutter-free convenience of wireless technology. This wireless connectivity has enabled a convenient mobile lifestyle for mobile computing users.

Supporting robust high-speed wireless connectivity, wireless USB utilizes the common WiMedia\* Ultra-Wideband (UWB) radio platform developed by the WiMedia Alliance.

**USB in the future**

When the SuperSpeed USB architecture was originally developed, requirements for future performance increases were factored into the solution.

Recent demands for even higher performance storage applications, video display, and USB hub and docking applications have identified a need to begin development of the next higher-speed version of SuperSpeed USB. This enhancement to USB technology is expected to double the existing SuperSpeed USB from 5 Gbps to 10 Gbps while retaining compatibility with all prior versions of USB. The specification for this is expected to be published by the USB Implementers Forum (USB-IF) around the middle of 2013, and initial end-user products based on this update specification are likely to appear in the market in the latter half of 2014.

**6.2.6 FireWire**

You have probably heard the term FireWire if you have any interest in digital video — or maybe you know it as Sony i.Link or as IEEE 1394, the official name for the standard. FireWire is a way to connect different pieces of equipment so they can easily and quickly share information.

Originally created by Apple and standardized in 1995 as the specification IEEE 1394 High Performance Serial Bus, FireWire is very similar to Universal Serial Bus (USB). The designers of FireWire had several particular goals in mind when they created the standard:

- Fast transfer of data
- Ability to put lots of devices on the bus
- Ease of use
- Hot-pluggable ability
- Provision of power through the cable
- Plug-and-play performance
- Low cabling cost
- Low implementation cost

FireWire is a method of transferring information between digital devices, especially audio and video equipment. Also known as IEEE 1394, FireWire is fast — the latest version achieves speeds up to 800 Mbps. At some time in the future, that number is expected to jump to an unbelievable 3.2 Gbps when manufacturers overhaul the current FireWire cables.

You can connect up to 63 devices to a FireWire bus. Windows operating systems (98 and later) and Mac OS (8.6 and later) both support it.

Let's say you have your digital camcorder connected to your home computer. When your computer powers up, it queries all of the devices connected to the bus and assigns each one an address, a process called enumeration. FireWire is plug-and-play, so if you connect a new FireWire device to your computer, the operating system auto-detects it and asks for the driver disc. If you've already installed the device, the computer activates it and starts talking to it. FireWire devices are hot pluggable, which means they can be connected and disconnected at any time, even with the power on.

### FireWire Specifications

The original FireWire specification, FireWire 400 (1394a), was faster than USB when it came out. FireWire 400 is still in use today and features:

- Transfer rates of up to 400 Mbps
- Maximum distance between devices of 4.5 meters (cable length)

The release of USB 2.0 — featuring transfer speeds up to 480 Mbps and up to 5 meters between devices — closed the gap between these competing standards. But in 2002, FireWire 800 (1394b) started showing up in consumer devices, and USB 2.0 was left in the dust. FireWire 800 is capable of:

- Transfer rates up to 800 Mbps
- Maximum distance between devices of 100 meters (cable length)
- The faster 1394b standard is backward-compatible with 1394a.

### FireWire vs. USB

The key difference between FireWire and USB is that FireWire is intended for devices working with a lot more data — things like camcorders, DVD players and digital audio equipment. FireWire and USB share a number of characteristics but differ in some important ways.

Implementing FireWire costs a little more than USB, which led to the adoption of USB as the standard for connecting most peripherals that do not require a high-speed bus.

Speed aside, the big difference between FireWire and USB 2.0 is that USB 2.0 is host-based, meaning that devices must connect to a computer in order to communicate. FireWire is peer-to-peer, meaning that two FireWire cameras can talk to each other without going through a computer.

### FireWire Cables and Connectors

FireWire devices can be powered or unpowered. FireWire allows devices to draw their power from their connection. Two power conductors in the cable can supply power (8 to 30 volts, 1.5 amps maximum) from the computer to an unpowered device. Two twisted pair sets carry the data in a FireWire 400 cable using a 6-pin configuration.

Notes

Figure 6.6: FireWire Adapter Cable of 9-pin Configuration



Source: <http://www.huppins.com//content/uploads/2013/05/AudioQuest-Forest-9-pin-to-9-pin-Firewire-Cable32.jpg>

Some smaller FireWire-enabled devices use 4-pin connectors to save space, omitting the two pins used to supply power.

FireWire 800 cables use a 9-pin configuration. Six of those pins are the same as the six pins in the 1394a connector (shown above). Two of the added pins provide a “grounded shield” to protect the other wires from interference, and the third added pin does nothing at this time [ref].

Because FireWire 800 is backward-compatible with FireWire 400, there are a variety of adapters available to facilitate the combination of both standards on the same bus. There are also two types of FireWire 800 ports available: a “bilingual” port accommodates both FireWire standards, while a b-only port accepts only a FireWire 800 connector.

### Self Assessment

Fill in the blanks:

1. The main operating system for Apple is ....., and PCs operate on .....
2. IDE is more commonly known as .....
3. SCSI stands for .....
4. .... is known as the father of SASI and SCSI due to his pioneering work first at Shugart Associates and then at Adaptec.
5. .... is also known as IEEE 1394.

### 6.3 Storage Devices

Alternatively referred to as storage, storage media, or storage medium, a storage device is a hardware device capable of holding information. There are two storage devices used in computers; a primary storage device such as computer RAM and a secondary storage device such as a computer hard drive. The secondary storage could be a removable, internal, or external storage.



Example: Drobo, an external secondary storage device.



Without a storage device, you and your computer would not be able to save any settings or information and would be considered a dumb terminal. Below, are some additional examples of storage devices that are used with computers.

### Types of Computer Storage

- Floppy diskette
- CD-ROM disc
- CD-R and CD-RW disc
- Cloud storage
- DVD-R, DVD+R, DVD-RW, and DVD+RW disc
- Jump drive and USB flash drive
- Hard drive
- LS-120
- Tape cassette
- Zip diskette

When saving anything on the computer, you will be asked for the storage location, which is where you want to save the information. By default most of the information you save will be saved to your computer hard drive, however, if you want to move the information to another computer you would want to save it to a removable storage device such as a Jump drive.



*Caution* Keep in mind that although these drives do send and receive information, they are not considered an input or output device.

### 6.3.1 Random Access Memory (RAM)

Random access memory (RAM) is the best known form of computer memory. RAM is considered “random access” because you can access any memory cell directly if you know the row and column that intersect at that cell.

The opposite of RAM is serial access memory (SAM). SAM stores data as a series of memory cells that can only be accessed sequentially (like a cassette tape). If the data is not in the current location, each memory cell is checked until the needed data is found. SAM works very well for memory buffers, where the data is normally stored in the order in which it will be used (a good example is the texture buffer memory on a video card). RAM data, on the other hand, can be accessed in any order.

Similar to a microprocessor, a memory chip is an integrated circuit (IC) made of millions of transistors and capacitors. In the most common form of computer memory, dynamic random access memory (DRAM), a transistor and a capacitor are paired to create a memory cell, which represents a single bit of data. The capacitor holds the bit of information—a 0 or a 1. The transistor acts as a switch that lets the control circuitry on the memory chip read the capacitor or change its state.

**Notes****How Much RAM Do You Need?**

It's been said that you can never have enough money, and the same holds true for RAM, especially if you do a lot of graphics-intensive work or gaming. Next to the CPU itself, RAM is the most important factor in computer performance. If you don't have enough, adding RAM can make more of a difference than getting a new CPU!

If your system responds slowly or accesses the hard drive constantly, then you need to add more RAM. If you are running Windows XP, Microsoft recommends 128MB as the minimum RAM requirement. At 64MB, you may experience frequent application problems. For optimal performance with standard desktop applications, 256MB is recommended. If you are running Windows 95/98, you need a bare minimum of 32 MB, and your computer will work much better with 64 MB. Windows NT/2000 needs at least 64 MB, and it will take everything you can throw at it, so you'll probably want 128 MB or more.

**6.3.2 Read-only Memory (ROM)**

Read-only memory (ROM), also known as firmware, is an integrated circuit programmed with specific data when it is manufactured. ROM chips are used not only in computers, but in most other electronic items as well.

There are five basic ROM types:

1. ROM
2. PROM
3. EPROM
4. EEPROM
5. Flash memory



*Notes* Each type has unique characteristics, which you'll learn about in this article, but they are all types of memory with two things in common:

- Data stored in these chips is non-volatile — it is not lost when power is removed.
- Data stored in these chips is either unchangeable or requires a special operation to change (unlike RAM, which can be changed as easily as it is read).
- This means that removing the power source from the chip will not cause it to lose any data.

**ROM at Work**

Similar to RAM, ROM chips contain a grid of columns and rows. But where the columns and rows intersect, ROM chips are fundamentally different from RAM chips. While RAM uses transistors to turn on or off access to a capacitor at each intersection, ROM uses a diode to connect the lines if the value is 1. If the value is 0, then the lines are not connected at all.

A diode normally allows current to flow in only one direction and has a certain threshold, known as the forward break over, that determines how much current is required before the diode will pass it on. In silicon-based items such as processors and memory chips, the forward break over voltage is approximately 0.6 volts. By taking advantage of the unique properties of

a diode, a ROM chip can send a charge that is above the forward break over down the appropriate column with the selected row grounded to connect at a specific cell. If a diode is present at that cell, the charge will be conducted through to the ground, and, under the binary system, the cell will be read as being “on” (a value of 1). The neat part of ROM is that if the cell’s value is 0, there is no diode at that intersection to connect the column and row. So the charge on the column does not get transferred to the row.

As you can see, the way a ROM chip works necessitates the programming of perfect and complete data when the chip is created. You cannot reprogram or rewrite a standard ROM chip. If it is incorrect, or the data needs to be updated, you have to throw it away and start over. Creating the original template for a ROM chip is often a laborious process full of trial and error. But the benefits of ROM chips outweigh the drawbacks. Once the template is completed, the actual chips can cost as little as a few cents each. They use very little power, are extremely reliable and, in the case of most small electronic devices, contain all the necessary programming to control the device. A great example is the small chip in the singing fish toy. This chip, about the size of your fingernail, contains the 30-second song clips in ROM and the control codes to synchronize the motors to the music.

### 6.3.3 Floppy and Hard Disks

The hard disk drive is the main, and usually largest, data storage device in a computer. The operating system, software titles and most other files are stored in the hard disk drive. The hard drive is sometimes referred to as the “C drive” due to the fact that Microsoft Windows designates the “C” drive letter to the primary partition on the primary hard drive in a computer by default.

While this is not a technically correct term to use, it is still common. For example, some computers have multiple drive letters (e.g. C, D, E) representing areas across one or more hard drives. A hard drive is usually the size of a paperback book but much heavier.

The sides of the hard drive have pre-drilled, threaded holes for easy mounting in the 3.5 inch drive bay in the computer case. Mounting is also possible in a larger 5.25 inch drive bay with an adapter. The hard drive is mounted so the end with the connections faces inside the computer.

The back end of the hard drive contains a port for a cable that connects to the motherboard. The type of cable used will depend on the type of drive but is almost always included with a hard drive purchase. Also here is a connection for power from the power supply.

Most hard drives also have jumper settings on the back end that define how the motherboard is to recognize the drive when more than one is present. These settings vary from drive to drive so check with your hard drive manufacturer for details. On the other hand, the floppy disk drive (FDD) was the primary means of adding data to a computer until the CD-ROM drive became popular. In fact, FDDs have been a key component of most personal computers for more than 20 years. Basically, a floppy disk drive reads and writes data to a small, circular piece of metal-coated plastic similar to audio cassette tape.

#### History of the Floppy Disk Drive

The floppy disk drive (FDD) was invented at IBM by Alan Shugart in 1967. The first floppy drives used an 8-inch disk (later called a “diskette” as it got smaller), which evolved into the 5.25-inch disk that was used on the first IBM Personal Computer in August 1981. The 5.25-inch disk held 360 kilobytes compared to the 1.44 megabyte capacity of today’s 3.5-inch diskette.

The 5.25-inch disks were dubbed “floppy” because the diskette packaging was a very flexible plastic envelope, unlike the rigid case used to hold today’s 3.5-inch diskettes. By the mid-1980s, the improved designs of the read/write heads, along with improvements in the magnetic

**Notes**

recording media, led to the less-flexible, 3.5-inch, 1.44-megabyte (MB) capacity FDD in use today. For a few years, computers had both FDD sizes (3.5-inch and 5.25-inch). But by the mid-1990s, the 5.25-inch version had fallen out of popularity, partly because the diskette's recording surface could easily become contaminated by fingerprints through the open access area.

### **6.3.4 Zip, Jaz, SyQuest and Optical Storage Devices**

For years, the Syquest 44 MB removable cartridges were the most widely used portable medium among multimedia developers and professionals, but Iomega's inexpensive Zip drives with their likewise inexpensive 100 MB, 250MB and 750 MB cartridges, built on floppy disk technology, significantly penetrated Syquest's market share for removable media. Iomega's Jaz cartridges, built based on hard disk drive technology, provided one or two gigabytes of removable storage media and have fast enough transfer for multimedia development. Pinnacle Micro, Yamaha, Sony, Philips, and others offer CD burners for making write-once compact discs, and some double quad speed players. As blank CD-R discs become available for less than a dollar each, this write-once media competes as a distribution vehicle.

#### **Magneto-Optical Drive**

A magneto-optical drive is a kind of optical disc drive capable of writing and rewriting data upon a magneto-optical disc. Both 130 mm (5.25 in) and 90 mm (3.5 in) form factors exist. The technology was introduced commercially in 1985. Although optical, they appear as hard disk drives to the operating system and do not require a special file system; they can be formatted as FAT, HPFS, NTFS, etc. Magneto optical drives are common in some countries, such as Japan because of the success of the MiniDisc, but have fallen into disuse in other countries.

### **6.3.5 Digital Versatile Disc (DVD)**

DVD (Digital Video Disc or Digital Versatile Disc), is a new medium for the distribution of digital data. A DVD disc looks much the same as a standard audio CD disc and works in much the same way. It is a silvery platter, 12 cm in diameter, with a hole in the center. Like a CD, a DVD disc is divided into tracks and data are stored in a spiral trail of tiny pits on a reflective metal surface embedded in plastic that correspond to the zeros and ones of the digital information contained within the tracks. As the disc revolves, the laser beam follows the spiral, reads the information from the pits, and then plays back that information. But here is where the similarity ends.

In order to store large amounts of diverse information, a disc with a large capacity is essential. DVD achieves this capacity by reducing the track spacing to about half that of a CD, making the pits smaller and the spiral tighter, and by recording the data in as many as four layers, two on each side of the disc by using a semi-transparent gold layer atop the reflective silver-colored layer. In order to read the data, a laser with the ability to read in much finer detail is required. Using a lower-power beam, the laser can read the data from the gold layer; then, with an increase in power, it can access and read the silver layer.

While the laser in an ordinary CD-ROM drive has a 780-nanometer (nm) wavelength, DVD drives use lasers with 650-nm or 635-nm wavelengths, thereby supporting more than double the pits per track, and more than double the tracks per recording surface. Other advances, such as a new sector format, better error-correction code, and improved channel modulation, raise the data density an additional one and a half times. By focusing the laser light through a larger aperture lens, a narrower focus is obtained and high-density reading is achieved.

A DVD disc is comprised of two 0.6 mm thick discs bonded back to back, which not only helps strengthen the disc but gives it the same 1.2 mm thickness as a CD. This bonded configuration also makes these discs less prone to warping due to heat and humidity compared to the single CD disc. Most DVD discs can store 4.7 GB of data on each side, or 9.4 GB total. However, there is a technique for increasing density that will soon result in discs that can hold up to 17 GB of data, the equivalent of 26 normal CD-ROMS. This technique, adding another data layer, would double the capacity of a single side. By making the first layer semi-transparent, a second laser could actually punch through and read the data on the layer beneath. This technique sacrifices a little capacity per side, down to 8.5 GB, but by bonding these two dual-layer sides together, a 17 GB capacity is achieved. Also, through this ability to store data much more tightly, DVD drives throughput can exceed that of a 9x CD-ROM drive, and can transfer data up to 2.7MB per second.

### 6.3.6 CD-ROM

CD-ROM (Compact Disc, read-only-memory) is an adaptation of the CD that is designed to store computer data in the form of text and graphics, as well as hi-fi stereo sound. The original data format standard was defined by Philips and Sony in the 1983 Yellow Book. Other standards are used in conjunction with it to define directory and file structures, including ISO 9660, HFS (Hierarchical File System, for Macintosh computers), and Hybrid HFS-ISO. Format of the CD-ROM is the same as for audio CDs: a standard CD is 120 mm (4.75 inches) in diameter and 1.2 mm (0.05 inches) thick and is composed of a polycarbonate plastic substrate (under layer – this is the main body of the disc), one or more thin reflective metal (usually aluminium) layers, and a lacquer coating.

#### Data Encoding and Reading

The CD-ROM, like other CD adaptations, has data encoded in a spiral track beginning at the centre and ending at the outermost edge of the disc. The spiral track holds approximately 650 MB of data. That's about 5.5 billion bits. The distance between two rows of pits, measured from the centre of one track to the centre of the next track is referred to as track pitch. The track pitch can range from 1.5 to 1.7 microns, but in most cases is 1.6 microns.

### 6.3.7 CD-ROM Players

Also called a CD-ROM drive, a device that can read information from a CD-ROM. CD-ROM players can be either internal, in which case they fit in a bay, or external, in which case they generally connect to the computer's SCSI interface or parallel port. Parallel CD-ROM players are easier to install, but they have several disadvantages: They're somewhat more expensive than internal players, they use up the parallel port which means that you can't use that port for another device such as a printer, and the parallel port itself may not be fast enough to handle all the data pouring through it.

There are a number of features that distinguish CD-ROM players, the most important of which is probably their speed. CD-ROM players are generally classified as single-speed or some multiple of single-speed.



*Example:* A 4X player access data at four times the speed of a single-speed player.

Within these groups, however, there is some variation. Also, you need to be aware of whether the CD-ROM uses the CLV or CAV technology. The reported speeds of players that use CAV are generally not accurate because they refer only to the access speed for outer tracks. Inner tracks are accessed more slowly.

**Notes**

Two more precise measurements are the drive's access time and data transfer rate. The access time measures how long, on average, it takes the drive to access a particular piece of information. The data transfer rate measures how much data can be read and sent to the computer in a second.

Finally, you should consider how the player connects to your computer. Many CD-ROMs connect via a SCSI bus. If your computer doesn't already contain such an interface, you will need to install one. Other CD-ROMs connect to an IDE or Enhanced IDE interface, which is the one used by the hard disk drive; still others use a proprietary interface.

### 6.3.8 CD Recorders

A CD burner is the informal name for a CD recorder, a device that can record data to a compact disc. CD-Recordable (CD-R) and CD-Rewritable (CD-RW) are the two most common types of drives that can write CDs, either once (in the case of CD-R) or repeatedly (in the case of CD-RW). In the recording process, the data is actually etched into the disc (burned) with a laser, as compared with non-recordable CDs. Audio CDs and CD-ROMs are pressed from copies of the original recordings (which are burned by lasers). Since the non-recordable CDs are manufactured in this manner, they can not be written, or rewritten in a desktop environment.

CD-Rs and CD-RWs, like all CDs, are made up of a polycarbonate substrate, a thin metal coating, and a protective outer layer. In a CD-R, a layer of organic polymer dye between the polycarbonate and metal layers serves as the recording medium. The composition of the dye is permanently transformed by exposure to a specific frequency of light. Some CD-Rs have an additional protective layer to make them less vulnerable to damage from scratches, since the data – unlike that on a regular CD – is closer to the label side of the disc. A pregrooved spiral track helps to guide the laser for recording data, which is encoded from the inside to the outside of the disc in a single continuous spiral. The laser creates marks in the dye layer that mimic the reflective properties of the pits and lands (lower and higher areas) of the traditional CD. The distinct differences in the way the areas reflect light register as digital data that is then unencoded for playback. With packet writing software and a compatible CD-R or CD-RW drive, it is possible to save data to a CD-R in the same way as one can save it to a floppy disk, although – since each part of the disk can only be written once – it is not possible to delete files and then reuse the space. The composition of the dye is permanently transformed by exposure to the laser.

In a CD-RW, the dye is replaced with an alloy that can change back and forth from a crystalline form when exposed to a particular light, through a technology called optical phase change. The patterns created are less distinct than those of other CD formats, requiring a more sensitive device for playback. Only drives designated as "MultiRead" are able to read CD-RW reliably. Similar to CD-R, the CD-RW's polycarbonate substrate is performed with a spiral groove to guide the laser. The alloy phase-change recording layer, which is commonly a mix of silver, indium, antimony and tellurium, is sandwiched between two dielectric layers that draw excess heat from the recording layer. After heating to one particular temperature, the alloy will become crystalline when it is cooled; after heating to a higher temperature it will become amorphous (won't hold its shape) when it is cooled. By controlling the temperature of the laser, crystalline areas and non-crystalline areas are formed. The crystalline areas will reflect the laser, while the other areas will absorb it. The differences will register as binary data that can be unencoded for playback. To erase or write over recorded data, the higher temperature laser is used, which results in the non-crystalline form, which can then be reformed by the lower temperature laser.

The first CD recorders were made available in 1988, but were not an option for the average home recorder because, with the requisite hardware and software along with high cost. However, nowadays CD recorders have become less expensive.

### 6.3.9 Videodisc Players

Notes

Videodisc (or video disc) is a general term for a laser- or stylus-readable random-access disc that contains both audio and analogue video signals recorded in an analog form. Typically, it is a reference to any such media that predates the mainstream popularity of the DVD format.

Video discs can be classed based on their playback mechanism:

- Mechanical
  - ❖ Phonovision
  - ❖ Phonovid
  - ❖ Ted
  - ❖ Visc
- Capacitance Based
  - ❖ CED, VHD
- Optical discs
  - ❖ Reflective
  - ❖ Laserdisc, CD, DVD, Blu-ray, etc.
- Transmissive
  - ❖ Thomson CSF system
  - ❖ Laserfilm



*Did u know?* A standard size videodisc can hold up to 30 minutes of high quality, motion video, or up to 54,000 still frames on each side.

## 6.4 Input Devices

In computing, an input device is any peripheral (piece of computer hardware equipment) used to provide data and control signals to an information processing system such as a computer or other information appliance.



*Example:* Some of the input devices include keyboards, mice, scanners, digital cameras and joysticks.

Many input devices can be classified according to:

- modality of input (e.g. mechanical motion, audio, visual, etc.)
- the input is discrete (e.g. key presses) or continuous (e.g. a mouse's position, though digitized into a discrete quantity, is fast enough to be considered continuous)
- the number of degrees of freedom involved (e.g. two-dimensional traditional mice, or three-dimensional navigators designed for CAD applications)

Pointing devices, which are input devices used to specify a position in space, can further be classified according to:

Notes

- Whether the input is direct or indirect. With direct input, the input space coincides with the display space, i.e. pointing is done in the space where visual feedback or the pointer appears. Touchscreens and light pens involve direct input.



*Example:* It involves indirect input include the mouse and trackball.

- Whether the positional information is absolute (e.g. on a touch screen) or relative.



*Example:* With a mouse that can be lifted and repositioned).

### 6.4.1 Keyboard Entry

In keyboard entry, a user types characters, numeric and special symbols using a keyboard. The input usually appears on a monitor. A keyboard entry might be the most common way to input data.

#### Keyboards

A keyboard is a device used to encode data by key depression, which enters information into a system. The keyboard converts alphabets and numbers, and other special symbols into electrical signals that processor can understand and process. These signals are sent to the computer's CPU. There are three different layouts.

1. **QWERTY:** This is a standard keyboard layout. QWERTY indicates the arrangement of the upper left corner six letters in the first row of the alphabetic keys.
2. **AZERTY:** This is a keyboard layout that is similar to the QWERTY layout and some European countries use this keyboard. This layout is slightly modified from the QWERTY keyboard.
3. **Dvorak:** This is another keyboard layout modified greatly from a standard layout. The keyboard is devised to increase typing speed by placing frequently used keys more naturally. In the past, mechanical jams were a problem in typing. Thus, the standard keyboard layout was designed to limit typing speed. Interesting, huh?

#### Terminals

A terminal is an input/output device that usually includes a keyboard for input, a video display for output, and a communications link to send and receive information. There are three different types:

1. **Dumb Terminal:** This is an input/output terminal that does not have a capability of processing. It only enters and receives data without processing.
2. **Smart Terminal:** This terminal has some processing capability. It has a small memory. It performs some editing of data before sending them to a main computer.
3. **Intelligent Terminal:** This is a terminal that has a full processing capability. The terminal has a processing unit, primary storage. It may or may not have local storage. Recently, most intelligent terminals have local disk. An intelligent terminal is actually a microcomputer with communications capability.

**Recent Trends:** A recent trend has been the use of microcomputers as terminals. As prices of microcomputers have dropped, companies have tended to buy intelligent terminals (microcomputers) instead of dumb terminals. It is because microcomputers can work exactly like dedicated terminals with the appropriate software and communications links.



## 6.4.2 Pointing Devices

Notes

A pointing device is an external tool that is used to move objects around and also to select options from menus. The pointing device is an element of the graphical user interface. It manipulates on screen objects to issue commands.



*Example:* Some of pointing devices include the mouse, trackball, light pen, pen for graphic tablet, joystick, touch screen, wand, head mounted display, virtual reality glasses, and 3-D mouse.

The concept of the pointing device was developed in 1970 by Douglas Engelbart as another way to input information into the computer other than through the keyboard. This input device has become popular and with the growth of the graphical user interface it has become one of the most necessary and important tools of the computer.

The mouse is included in almost every computer that is sold today. Besides becoming an important input tool, it has provided access to the computer for many individuals with disabilities that might not otherwise have the opportunity to use the computer.



*Caution* The pointing device also lets you double click on an icon to start a program application; and in the WINDOWS 95 operating system you can use the mouse to drag a file or document to the Recycling Bin to delete a file.

### Mousing Around

The computer mouse moves by way of a roller and ball system. When you move the mouse across the desktop, the ball underneath rolls. This ball corresponds to the position of what is called a pointer on the screen. The pointer is usually shaped like an arrow, though some people like to change their pointer to look like objects. (One person in our group has changed his pointer to an ink pen icon.) When you move the pointer around it is called mousing. The speed of the mouse can be managed by your computer operating system software, or a commercial application program for your mouse. You can drag objects on the screen by clicking on the object, holding down on the mouse button, and rolling the mouse across the desktop until you get the object to a new location. When you reach the spot that you want, let go of the mouse button.

Most mice come with two buttons. You use the left button on the mouse to do most selecting of objects. The right button can be used for some menu actions. This is especially true when using browser software to examine and manipulate pictures and graphics on the Internet. There is a three button mouse and the middle button can be programmed for specific application software, but usually the two button mouse is used the most. If you are left handed, you can change to a left-handed mouse option in your software so that you can use your mouse in your left hand.

### Types of Pointing Devices

**Pen:** The pen lets you draw on what is called a digitizing tablet that mirrors the surface area of the computer screen. The pen can be used as a standard mouse (without wires connected to it) or also as a free flowing drawing device. The pen is useful for drawing since drawing graphics with a mouse tends to be somewhat difficult.

**Mouse:** The mouse is a hand held device that lets you point to and selected items on your screen. In a PC mouse there are mostly 2-3 buttons and on a Mac there is one. A ball under the mouse senses movement. To ensure smooth motion your should remove the ball and clean it regularly.

**Notes**

**Cordless Mouse:** The cordless mouse is a lot better than a normal mouse thus by reducing the clutter of the work space needed to move the mouse around. This mouse runs on a battery. When you move the mouse it sends an infrared beam to a sensor which interprets it causing it to move.

**Trackball:** The trackball is an upside-down mouse that remains stationary on your desk. It is the same principle as the mouse except that the rollers are reversed and the ball is on top. This ball does not need as much attention as the normal mouse because the only thing that touches it is your hand as the normal mouse touches a surface.

**Touchpad:** The touchpad has sensors that sense your touch. When they sense your touch they send a signal to the computer to move the mouse pointer to that location on the screen. To move the pointer, slide your finger across the Touchpad surface in the direction you want the pointer to go. Use the Touchpad buttons like the corresponding buttons on an external mouse. To scroll up and down using the Touchpad vertical scroll zone, slide your finger up or down over the lines.



**Caution** If you are using the Touchpad to move the pointer, you must lift your finger off the Touchpad before moving it to the scroll zone. Simply sliding your finger from the Touchpad to the scroll zone will not activate the scrolling function.

**Joystick:** The joystick allows the user to move quickly in computer games.

**Light Pen:** The light pen system allows the user to touch the computer screen with a lighted pen to activate commands and make selections.

**Touch Screen:** The touch screen lets the user touch the area to be activated by using the finger or hand.

### Other Pointing Devices

There are many other pointing devices available, including head Mounted Virtual Reality Displays, Wands, Special Trackballs, Data Gloves, and Special 3-D Flying Mice that can go in six different directions. These devices are currently the newest pointing devices. Some of these devices are very expensive and may take time to learn. It is advisable to try these devices before purchasing, when possible.

### Scanner

Scanners allow a computer to convert a picture or object into digital code that allows the computer to display and use an image. A scanner's sophistication is the ability to translate an unlimited number of analogue voltage levels to digital values. The computer is not able to use graphics unless they are in a form that they can understand. The scanner takes the information it sees on a page and converts into code that the computer can use. A picture once scanned can be edited, printed, or used in an application. Scanners can come with specialized software called optical character recognition (OCR). This software can read text as printed or written. The information can then be manipulated in the computer.

**Important Note:** A feature of the scanner is the resolution. This is how sharp and detailed the scanner can read. Scanners are measured in dots per inch. The higher the resolution, the more the memory that is required to scan the file. The bigger the file that is produced. Larger files take longer scanning time. If a file is big and you need to fit it on a diskette, you may run into a problem storing it unless you store it to the hard drive or another high capacity drive. Therefore, if you are wanting to produce a file for screen output, you should scan at 72 dpi because that the best resolution that the monitor can display. It is the same of the printed output. If you only have a 300 dpi printer, do not scan the file at a higher resolution since the printer will only print it at that resolution.

Figure 6.7: An HP Scanner

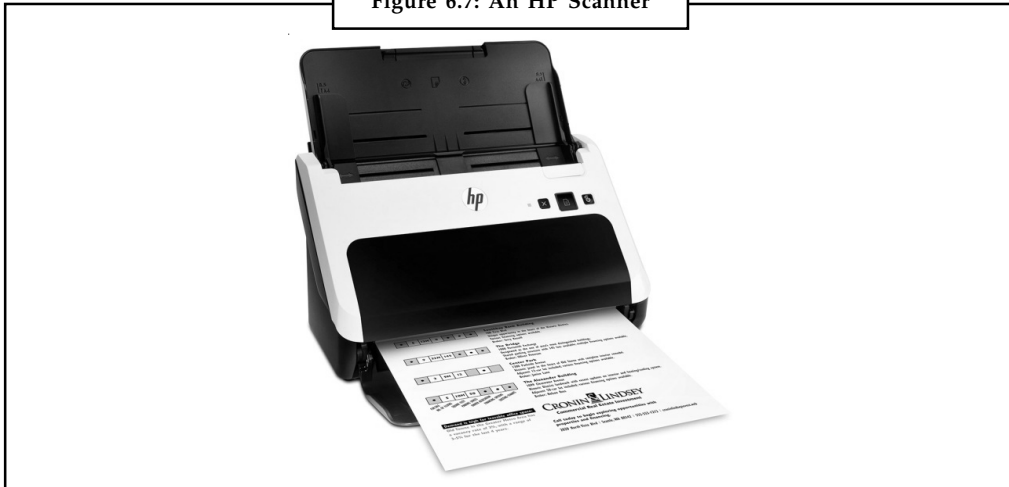

Source: <http://www9.pcmag.com/media/images/324918-hp-scanjet-pro-3000-s2-sheet-feed-scanner.jpg>

### Types of Scanners

- **Sheet-Fed Scanner:** Sheet-fed scanners have mechanical rollers that move the paper past the scan head.
- **Flatbed Scanner:** Flatbed Scanners have a glass window where the item to be scanned is placed on top of a while the head moves past the item. This method is similar to a Xerox machine.
- **Hand Held Scanners:** Hand held scanners are small, portable scanners that depend on a human operator to move the head across the object or image to be scanned.

### Colour vs. Grey scale

**Grey Scale:** Using black and white and shades of grey, the scanner is able to translate the image into grey scales. Why would you use a grey scale scanner? If you plan to print on a black and white printer, it is most cost effective since colour ink is so expensive. Text is best done on a grey scale scanner.

**Coloured:** A colour scanner scans images in red, blue, and green shades. This scanner is more expensive in terms of final print output . A colour scanner usually costs more than a grey scale scanner. If you plan on doing presentation work, work with colour photographs, or any sort of task that requires a colour output, then use a colour scanner. With this scanner you can also choose options of scanning such as line art (scanning the image only in black or white), grey scale (black, white, and shades of grey, or colour (shades of red, blue, and green).

### Touchscreen

A touchscreen is an electronic visual display that the user can control through simple or multi-touch gestures by touching the screen with one or more fingers. Some touchscreens can also detect objects such as a stylus or ordinary or specially coated gloves. The user can use the touchscreen to react to what is displayed and to control how it is displayed, for example, by zooming the text size.

## Notes

Widely used on ATM machines, retail point-of-sale terminals, car navigation systems and medical monitors, the touch screen became wildly popular on handhelds after Apple introduced the iPhone in 2007.

The touchscreen enables the user to interact directly with what is displayed, rather than using a mouse, touchpad, or any other intermediate device (other than a stylus, which is optional for most modern touchscreens).

Touchscreens are common in devices such as game consoles, all-in-one computers, tablet computers, and smartphones. They can also be attached to computers or, as terminals, to networks. They also play a prominent role in the design of digital appliances such as personal digital assistants (PDAs), satellite navigation devices, mobile phones, and video games.

The popularity of smartphones, tablets, and many types of information appliances is driving the demand and acceptance of common touchscreens for portable and functional electronics. Touchscreens are popular in the medical field and in heavy industry, as well as in kiosks such as museum displays or room automation, where keyboard and mouse systems do not allow a suitably intuitive, rapid, or accurate interaction by the user with the display's content.

Historically, the touchscreen sensor and its accompanying controller-based firmware have been made available by a wide array of after-market system integrators, and not by display, chip, or motherboard manufacturers. Display manufacturers and chip manufacturers worldwide have acknowledged the trend toward acceptance of touchscreens as a highly desirable user interface component and have begun to integrate touchscreens into the fundamental design of their products.



*Notes* There are four main touchscreen technologies:

1. **Resistive:** comprises several layers, the most important of which are two thin, transparent electrically-resistive layers separated by a thin space.
2. **Capacitive:** uses a layer of capacitive material to hold an electrical charge.
3. **Surface Acoustic Wave:** it uses ultrasonic waves that pass over the touchscreen panel.
4. **Infrared:** uses an array of infrared LED and photodetector pairs around the edges of the screen to detect a disruption in the pattern of LED beams.

## Digitizer

Digitizer is an input device which converts analogue information into a digital form. Digitizer can convert a signal from the television camera into a series of numbers that could be stored in a computer. They can be used by the computer to create a picture of whatever the camera had been pointed at.

Digitizer is also known as Tablet or Graphics Tablet because it converts graphics and pictorial data into binary inputs. A graphic tablet as digitizer is used for doing fine works of drawing and images manipulation applications.

## Microphone

Microphone is an input device to input sound that is then stored in digital form. The microphone is used for various applications like adding sound to a multimedia presentation or for mixing music.

### **Magnetic Ink Card Reader (MICR)**

Notes

MICR input device is generally used in banks because of a large number of cheques to be processed every day. The bank's code number and cheque number are printed on the cheques with a special type of ink that contains particles of magnetic material that are machine readable.

This reading process is called Magnetic Ink Character Recognition (MICR). The main advantages of MICR is that it is fast and less error prone.

### **Optical Character Reader (OCR)**

OCR is an input device used to read a printed text. OCR scans text optically character by character, converts them into a machine readable code and stores the text on the system memory.

### **Bar Code Readers**

Bar Code Reader is a device used for reading bar coded data (data in form of light and dark lines). Bar coded data is generally used in labelling goods, numbering the books etc. It may be a hand held scanner or may be embedded in a stationary scanner. Bar Code Reader scans a bar code image, converts it into an alphanumeric value which is then fed to the computer to which bar code reader is connected.

### **Optical Mark Reader (OMR)**

OMR is a special type of optical scanner used to recognize the type of mark made by pen or pencil. It is used where one out of a few alternatives is to be selected and marked. It is specially used for checking the answer sheets of examinations having multiple choice questions.

## **6.5 Output Devices**

In this section we consider the various output devices which are attached to a computer for multimedia development and delivery.

### **6.5.1 Sound Recording Equipment**

The use of sound in its various forms is a component of a multimedia application. The quality of the recording equipment is important in determining the final quality of the sound. Sound recording equipment ranges from a simple tape cassette recorder for low budget amateur sound productions to a fully equipped professional recording studio. The essential pieces of hardware for recording sound are microphones, musical instruments, digital audio tape (DAT) recorder, a multitrack mixing console for editing and mixing various sources of sound, etc. DAT recorders enable sound to be recorded at sampling rates up to 96KHz and 16 bits per sample. The medium for the recording, editing and capture of music is generally undertaken using the MIDI data format and today most electronic instruments and equipment associated with music support it.

Once the sound has been recorded it must be input into a computer for further editing and integration into a multimedia application. Output from digital sources like a DAT recorder can be input directly into a computer without conversion, however analogue sources need to be captured, i.e. converted from analogue to digital. Standard soundcards installed in most desktop computers can receive and convert analogue sound sources. Sound cards have a number of different input sockets for various sound sources and can support sample frequencies up to 192KHz at 24 bits per sample. Sound cards also convert sound from digital to analogue for output to speakers.

### 6.5.2 Speakers

Another crucial output device for multimedia applications are the speakers which provide the sound outputs. Speakers are driven by sound cards as explained in the last section. Most sound cards support the SoundBlaster standard developed by Creative Labs and the General MIDI standard for sound reproduction. Speakers used with desktop computers usually require their own power source and have built-in amplifiers.

### 6.5.3 Monitors

The most important output device for multimedia development and delivery is the monitor. Thus the quality of monitors and the graphic display cards that drive them are important considerations for multimedia developers. Multimedia developers need to use large 17" or 19" (measured diagonally across the screen) monitors in order to have room to display the multimedia application under development and the various dialogue boxes of the authoring tools. Some multimedia developers use two monitors that are driven using special graphics cards so that they can see the multimedia application on one screen and have the tools displayed on the other.

Large monitors do not necessarily mean that more information can be displayed. The amount of detail displayed on a monitor is dictated by its screen resolution and the resolution that the graphics display card is capable of delivering. Multimedia development needs large monitors that support high screen resolutions and a large number of colours. Currently, the most common standard for graphic display cards on PCs used for multimedia development is the Ultra Extended Graphics Array or UXGA which enables a monitor to display 1600 by 1200 pixels and up to 16.7 million colours. There are a number of other competing standards. Graphic display cards have their own special RAM which contains the current screen display pixel by pixel. Some multimedia tasks, like video and image editing and displaying 3D graphics, require between 4 and 8Mbytes of graphic display RAM.

An important type of monitor for use in point of information applications are touchscreens which are both input and output devices. Touch screens are an intuitive way for users to interact with a multimedia application by allowing them to touch buttons and links directly rather than indirectly via a mouse or other pointing device. Touch screens include three key components:

- a touch screen sensor panel that generates a voltage to indicate where the screen was touched;
- a controller that converts the voltage into a digital signal and transmits it to the processor; and
- a software driver to translate the digital signal into data that emulates the mouse.

There is one other type of monitor which is used in public multimedia presentations called a data projector. Data projectors enable the normal output from a computer to be projected onto a large screen so that a larger audience can see. Some data projectors include special display screens which act like enormous digitising tablets so the display can be used as if it were a touch screen.

### 6.5.4 Video Recording Equipment

The hardware used in professional video production is beyond the scope of this book so we focus on the kind of equipment that could be used by a small independent multimedia design

company or home users. Basic video recording equipment includes either an analogue or digital video camera and a video capture card installed in a desktop computer. Video capture cards are different to graphic display cards which are not capable of video capture. Although many video experts still prefer using analogue cameras, digital video cameras are becoming more standard offering 6Mb/s data rate or up to 30 frames per second at a resolution of 720 by 480 pixels.

Once a piece of video has been recorded it needs to be captured; digital video cameras can be connected directly to one of the USB or serial ports on the desktop computer but analogue video needs to be captured via a video capture card. Video capture cards receive analogue video signals through one of their ports and sample it at a frequency up to 30 frames per second, a resolution of 768 by 576 pixels and a sample size of 24 bits per pixel. Video capture requires high specification desktop computers with a fast, high capacity hard disk drive to cope with the input video data.

Good video greatly enhances your project whereas poor video will ruin it. Whether you delivered your video from tape using VISCA controls, from videodisc, or as a QuickTime or AVI movie, it is important that your source material be of high quality.

### 6.5.5 Projectors

The delivery of visual media through projection is an effective way to entertain, educate, and communicate with people on a large scale. The use of a multimedia projector gives the presentation agent a number of options when configuring a stage for the viewing audience. Whether conducting a presentation in the corporate environment, educational programs in the classroom, projecting motion pictures in front of a large audience, or in the home, the multimedia projector is a valuable tool for communication and entertainment.

At its most basic, a multimedia projector simply projects an image on a screen. There are a number of features available, however, that expand this basic functionality. Some multimedia projectors can be configured to project a computer's video signal, outputs from DVD players, and also direct connections from cable and satellite systems. Depending on the needs of the user and their project, there is a projection device designed for almost every application, level of quality, and size of audience. The prices of these devices can fluctuate greatly depending on its specifications.

A multimedia projector processes a specific video signal and projects a corresponding image on a large screen using a lens system. Video projectors incorporate the use of a very bright light to display the image. The video signal rides along a special digitized light that is then projected on thousands of reflectors within the projector, which then shine the image onto a screen. Many intelligently designed projectors can correct inconsistencies and distortions in the projection. Depending on the specifications of the multimedia projector, its resolution capabilities and cost, a unit can reproduce the input with sharp detail and clarity.

These projectors are capable of numerous display resolutions, including 800 × 600 pixels (SVGA), 1024 × 768 pixels (XGA), 1280 × 720 pixels (720p), and 1920 × 1080 pixels (1080p). Most importantly, the cost of a projector is not only depended on its resolution, but also by its light output. A high lumen output is essential for viewing on larger screens or in locations that contain a high level of ambient light.

An output level between 1500 to 2500 lumens suitable for smaller screens with controlled lighting or low ambient light. In a room equipped with a medium-sized screen, ambient light, or dimmed light, a 2500 to 4000 lumen level is a good choice. A projector with a 4000 lumen output level should work well with very large screens such as those used in a large conference room with little or no lighting control.

Notes

Figure 6.8: A LG Projector



Source:[http://www.koreamin.com/ebay/Computers&Networking/Projector/lg\\_mini\\_Projector/Projector\\_LG\\_Mini\\_Beam\\_TV\\_HX350T2.jpg](http://www.koreamin.com/ebay/Computers&Networking/Projector/lg_mini_Projector/Projector_LG_Mini_Beam_TV_HX350T2.jpg)

Most multimedia projectors have 5-8 different inputs. Many models now offer wired, wireless, or both types of networking, and some can even present from content passed along the network. Some with wireless networking can even switch between many different computers (laptops) in the room!



*Did u know?* LG's HW300T mini projector is a new range of projector that does not need computers or Blu-ray players. It can stream directly from internet.

### 6.5.6 Printers

The last type of output device used in multimedia is the printer. For multimedia development it is important to have a high quality colour printer to show screen shots to clients and for discussing particular elements of a multimedia project. It is impossible for a printer to exactly match the on-screen colours, however they are helpful in seeing the general look and feel of an application.

There are two types of colour printer – laser printer and inkjet printer. An efficient inkjet printer is capable of outputting about 1.5 pages per minute at a quality of 1200 by 600 dpi. On the other hand, an equally efficient laser printer of the same price can output four pages per minute at a quality of 600 by 600 dpi.

The new inkjet and colour laser printers allow you to change each of the colour cartridges (cyan, magenta, yellow and black) separately. The latest inkjet printers reduce the printing cost by allowing you to purchase each of the colour print heads and associated ink cartridges separately. Currently colour laser printers have a lower cost per page than an equivalent inkjet printer.

### Self Assessment

Fill in the blanks:

6. Laser printer and ..... are two types of printers.
7. A monitor which is used in public multimedia presentations called a .....
8. .... is a type of optical scanner used to recognize the type of mark made by pen or pencil.
9. 3-D Flying Mice is a .....
10. The floppy disk drive (FDD) was invented at IBM by ..... in 1967.



*Task* Prepare a report on the various input and output devices of a computer.





Case Study

## How do I use a scanner?

**W**ould you like to keep a computerised copy of some old letters, newspaper articles, photos or drawings? If so, a scanner will do the job and – in some cases – you will be able to throw the originals away. You can also be creative and have fun scanning objects, which means using the scanner as a camera.

Scanners usually come with all the software you need. Scanning can be as simple as putting a document face down on the glass, pressing a button to begin the scan, and then saving the file onto your PC's hard drive.

But sometimes you will want to select the area of the original you want to scan, or want to lighten or darken the image. As when making photocopies, it can take three or four attempts to get the best result.

### Scanning software

If you are using the software that the manufacturer has provided to control the scanner, you will need to run that and select either 'Scan' or 'Preview'. If you are scanning a small photo, for example, you can use your mouse to crop the preview so that you just capture the image, not the surrounding area.

Alternatively, you can scan things into software such as Adobe Photoshop, which is sometimes bundled with scanners. Look on your program's File menu for the command used to acquire or import an image. Check the settings, click 'Preview' or 'Scan', and a scanned image will appear in your graphics or paint program.

There are several settings to adjust, and these may include Dust Removal and Colour Restoration for scanning old photos. If you can't see them, look for a way to switch from automatic scanning to a manual system.

### Step-by-step Guide

Scan mode, or Type of original. The best settings for a typed letter are not the same as for a colour photo. The scanner should have options for black-and-white or colour scans, and a choice of photos or documents, etc.

Scan density, or Image quality. For the best results with negatives, slides and photos, scan at the maximum optical resolution of your scanner, which should be the default setting. There is no point in setting a higher resolution than that. If you need to make a bigger print, you can do that in your graphics program. If the image is for viewing on a computer screen or uploading to Facebook, then you can resize it (in your graphics software) to the number of pixels required.

File format, or Save as type. You can set the scanner to send images in a particular format. The options commonly include PDF, JPG, TIFF and PNG. TIFF is often preferred by scanning professionals because it is 'lossless'. JPG is a compressed format that produces smaller files, but some information is lost.

If you scan a photo from a magazine, you may get an interference pattern or 'moiré effect'. Look for a de-screen filter or try a 'remove noise' or 'noise reduction' effect in your graphics software.

If you scan a typed or printed document, the scanner will still produce an image file. However, you can create a text file by using OCR (Optical Character Recognition) software

*Contd....*

Notes

such as Omnipage, Abbyy FineReader or FreeOCR. Microsoft Office includes an OCR tool – Microsoft Office Document Imaging – which will convert a TIFF image file to text. An Office program, OneNote, also lets you right-click an image and select 'Copy Text from Picture'.

**Get creative!**

Scanners can also be creative and fun, because you can create pictures by placing objects on the glass. Try flowers, fruits, fabrics, fingers and other flattish things.

The process is called 'scanner photography' or scanography, and it has been used by artists and photographers (such as Patri Feher) to produce stunning work..

Finally, the golden rule of scanning is to always keep your scanner clean. Smears and scratches have a habit of showing up on scans. A lint-free cloth and certain glass cleaners should do the trick. Never use anything rough, such as a paper towel. Treat the glass more like a camera lens than a window.

**Questions:**

1. Critically analyse the above case study in detail.
2. Scanners have become an integral part of multimedia. Elaborate.

Source: <http://www.bbc.co.uk/webwise/guides/using-a-scanner>

## 6.6 Summary

- The two types of desktop computer used for multimedia development are the Apple Mac and the Microsoft Windows based personal computer or PC.
- Most PCs have anywhere from 2 GB to 8 GB of RAM in laptops and desktops, while Macs usually have only 1 GB to 4 GB.
- Computers have three main storage devices – hard drive, floppy drive and CD-ROM drive.
- SCSI is a set of standards for physically connecting and transferring data between computers and peripheral devices.
- There are two storage devices used in computers; a primary storage device such as computer RAM and a secondary storage device such as a computer hard drive.
- Read-only memory (ROM), also known as firmware, is an integrated circuit programmed with specific data when it is manufactured.
- A hard drive is usually the size of a paperback book but much heavier.
- DVD (Digital Video Disc or Digital Versatile Disc), is a new medium for the distribution of digital data.

## 6.7 Keywords

*FireWire:* A method of transferring information between digital devices, especially audio and video equipment.

*Magneto-Optical Drive:* A kind of optical disc drive capable of writing and rewriting data upon a magneto-optical disc.

*Memory Chip:* An integrated circuit (IC) made of millions of transistors and capacitors.

**Serial Access Memory (SAM):** Stores data as a series of memory cells that can only be accessed sequentially (like a cassette tape).

Notes

## 6.8 Review Questions

1. Describe the history of floppy disk drives.
2. Write a short note on input devices of computer.
3. Discuss in brief about the output devices of computer.
4. Explain RAM and ROM.
5. Elucidate multimedia storage devices.
6. Define CD-ROM and CD-ROM player. Explain in detail.
7. A pointing device is an external tool that is used to move objects around. Explain.
8. Discuss various types of pointing devices.
9. What is a projector? Explain in detail.
10. Write a note on sound recording and video recording equipment.

## **Answers: Self Assessment**

- |  |                               |
|--|-------------------------------|
| 1. OSX, Microsoft Windows              | 2. ATA or Parallel ATA (PATA) |
| 3. Shugart Associates System Interface | 4. Larry Boucher              |
| 5. FireWire                            | 6. Inkjet printer             |
| 7. data projector                      | 8. Optical Mark Reader (OMR)  |
| 9. Pointing device                     | 10. Alan Shugart              |

## 6.9 Further Readings



### Books

Englander, I, (2000) *Architecture of Computer Hardware and Systems Software: An IT Approach*, (2nd edition), John Wiley and Sons.

Frederick P. Brooks, Jr., Kenan Professor of Computer Science. *The Mythical Man-Month: Essays in Software Engineering*, University of North Carolina at Chapel Hill.

K. Andleigh and K. Thakkar, *Multimedia System Design*, PHI, PTR.

Steve Rimmer (2000), *Advanced Multimedia Programming*, MHI.

Tay Vaughan, *Multimedia Making it work*, Seventh Edition, Tata McGraw-Hill Education Private Ltd.



### Online links

<http://nora.lis.uiuc.edu:3030/companion/view?docId=blackwell/9781405103213/9781405103213.xml&doc.view=print&chunk.id=ss1-2-10&toc.depth=1&toc.id=0>

**Notes**

[http://users.mct.open.ac.uk/yr258/papers/Rogers\\_Scaife98.pdf](http://users.mct.open.ac.uk/yr258/papers/Rogers_Scaife98.pdf)

<http://www.computerhope.com/jargon/s/stordevi.htm>

<http://www.icheg.org/icheg-game-history/timeline/>

<http://www.ict.griffith.edu.au/teaching/1611ICT/mm1alectures/l11/Writing%20For%20Multimedia%20Great%20Moments%20In%20Multimedia%20History.htm>

## Unit 7: Multimedia Software Tools

Notes

### CONTENTS

Objectives

Introduction

7.1 Text Editing and Word Processing Tools

7.1.1 Text Editor

7.1.2 Word Processor

7.2 OCR Software

7.2.1 Function of OCR

7.2.2 Features of OCR

7.2.3 History of OCR

7.2.4 Types of OCR Software

7.2.5 Techniques

7.2.6 Advantages of OCR

7.3 Painting and Drawing Tools

7.4 Summary

7.5 Keywords

7.6 Review Questions

7.7 Further Readings

### Objectives

After studying this unit, you will be able to:

- Understand the text editing and word processing tools
- Describe the OCR software
- Explain the painting and drawing tools

### Introduction

Multimedia authoring tools are tools which organize and edit your multimedia project. These tools are required to design the user interface for presenting the project to the learner. In other words, these tools are used to assemble various elements to make a single presentation. You can compose comprehensive videos and animations with these tools. There are four basic type of authoring tools viz. Page based tools (like Tool book, Visual Basic), (like Authorware), (like Macromedia Director) and Object Oriented tools (like Media Forge).



*Did u know?* Macromedia Authorware has a visual interface, which one has to simply drag and drop icons to create an application.

## 7.1 Text Editing and Word Processing Tools

A word processor is usually the first software tool computer users learn. From letters, invoices, and storyboards to project content, your word processor may also be your most often used tool, as you design and build a multimedia project. The better your eye boarding or typing skills, the easier and more efficient your multimedia day-to-day life will be.

Typically, an office or workgroup will choose a single word processor to share documents in a standard format. And most often, that word processor comes bundled in an office suite that might include spreadsheet, database, email, web browser, and presentation applications. Word processors such as Microsoft Word and WordPerfect are powerful applications that include spell checkers, table formatters, thesauruses, and pre-built templates for letters, resumes, purchase orders, and other common documents.

Many developers have begun to use OpenOffice ([www.openoffice.org](http://www.openoffice.org)) for word processing, spreadsheets, presentations, graphics, databases, and more. It can be downloaded and used completely free of charge for any purpose and is available in many languages. It can read and write files from other, more expensive, office packages. In many word processors, you can embed multimedia elements such as sounds, images, and video. Luckily, the population of single-finger typists is decreasing over time as children are taught keyboarding skills in conjunction with computer lab programs in their schools.

### 7.1.1 Text Editor

A text editor is program that allows you to open, view, and edit plain text files. Unlike word processors, text editors do not add formatting to text, instead focusing on editing functions for plain text.

Text editors are used by a wide variety of people, for a wide variety of purposes. Software programmers and web developers use text editors to write and edit in programming and markup languages. This is one of the primary purposes of text editors, and many of the features of text editing software are built to help these users read and write code. However, text editors are ideal tools for anyone who needs to write quickly and simply, read source code, or create text files.



*Caution* If you have Windows, you already have the default Notepad application installed on your system. Notepad is a very basic text editor with minimal features and low capabilities. If you only need a text editor for small tasks, Notepad will work just fine. Notepad's limitations become apparent if you try to do some more heavy duty text editing.

With more advanced text editors come more advanced and useful features. Syntax highlighting, one of the most useful tools in a text editor's repertoire, colour codes text based on the programming/markup language it written in. Other staple text editing features not included in Notepad are large file support, advanced find and replace, vertical selection editing, and document comparison, and more.

If you're looking for a Notepad replacement, many text editors are available online for download and purchase. The quality of such text editors varies greatly, and it's a good idea to research the different kinds available to find one that matches your needs before making a decision. Most text editors that you can buy allow you to download a trial version before committing to a purchase, and this is a great way to figure out what works for you.

A popular text editor in IBM's large or mainframe computers is called XEDIT. In UNIX systems, the two most commonly used text editors are Emacs and Vi. In personal computer systems, word processors are more common than text editors. However, there are variations of mainframe and UNIX text editors that are provided for use on personal computers.



*Example:* An example is KEDIT, which is basically XEDIT for Windows.

### 7.1.2 Word Processor

A word processor is a computer program that provides special capabilities beyond that of a text editor such as the WordPad program that comes as part of Microsoft's Windows operating systems. The term originated to distinguish text building programs that were "easy to use" from conventional text editors, and to suggest that the program was more than just an "editor." An early user of this term was Wang, which made a popular workstation system designed especially for secretaries and anyone else who created business letters and other documents.

In general, word processors screen the user from structural or printer-formatting markup (although WordPerfect and other word processors optionally let you see the markup they insert in your text). Without visible markup, it's possible to describe a word processor as having a WYSIWYG (what you see is what you get) user interface.

The most popular word processor is Microsoft Word, which is often purchased as part of Microsoft's Office suite. However, there are a number of other general and specialized word processors that have a user following.

## 7.2 OCR Software

OCR (Optical Character Recognition) also called Optical Character Reader is a system that provides a full alphanumeric recognition of printed or handwritten characters at electronic speed by simply scanning the form. More recently, the term Intelligent Character Recognition (ICR) has been used to describe the process of interpreting image data, in particular alphanumeric text.

Often you will have printed matter and other text to incorporate into your project, but no electronic text file. With OCR software, a flatbed scanner, and your computer, you can save many hours of re-keying printed words, and get the job done faster and more accurately than a roomful of typists.

OCR software turns bitmapped characters into electronically recognizable ASCII text. A scanner is typically used to create the bitmap. Then the software breaks the bitmap into chunks according to whether it contains text or graphics, by examining the texture and density of areas of the bitmap and by detecting edges. The text areas of the image are then converted to ASCII characters using probability and expert system algorithms.

Most OCR applications claim about 99 per cent accuracy when reading 8-to 36-point printed characters at 300 dpi and can reach processing speeds of about 150 characters per second. These programs do, however, have difficulty recognizing poor copies of originals where the edges of characters have bled; these and poorly received faxes in small print may yield more recognition errors than it is worthwhile to correct after the attempted recognition.



*Example:* Imagine you've got a paper document, for example, magazine article, brochure, or PDF contract your partner sent to you by email. Obviously, a scanner is not enough to make this information available for editing, say in Microsoft Word. All a scanner can do is create an

**Notes**

image or a snapshot of the document that is nothing more than a collection of black and white or colour dots, known as a raster image. In order to extract and repurpose data from scanned documents, camera images or image-only PDFs, you need an OCR software that would single out letters on the image, put them into words and then – words into sentences, thus enabling you to access and edit the content of the original document.

### 7.2.1 Function of OCR

Forms containing characters images can be scanned through scanner and then recognition engine of the OCR system interpret the images and turn images of handwritten or printed characters into ASCII data (machine-readable characters).

Therefore, OCR allows users to quickly automate data capture from forms, eliminate keystrokes to reduce data entry costs and still maintain the high level of accuracy required in forms processing applications.

### 7.2.2 Features of OCR

The technology provides a complete form processing and +documents capture solution. Usually, OCR uses a modular architecture that is open, scalable and workflow controlled. It includes forms definition, scanning, image pre-processing, and recognition capabilities.

### 7.2.3 History of OCR

Early optical character recognition could be traced to activity around two issues: expanding telegraphy and creating reading devices for the blind. In 1914, Emanuel Goldberg developed a machine that read characters and converted them into standard telegraph code. Around the same time, Edmund Fournier d'Albe developed the Optophone, a handheld scanner that when moved across a printed page, produced tones that corresponded to specific letters or characters.

### 7.2.4 Types of OCR Software

- **Optical Character Recognition (OCR):** targets typewritten text, one glyph or character at a time.
- **Optical Word Recognition (OWR):** targets typewritten text, one word at a time (for languages that use a space as a word divider). (Usually just called "OCR".)
- **Intelligent Character Recognition (ICR):** also targets handwritten print script or cursive text one glyph or character at a time, usually involving machine learning. Artificial neural networks can be made indifferent to both affine and non-linear transformations.
- **Intelligent Word Recognition (IWR):** also targets handwritten print script or cursive text, one word at a time. This is especially useful for languages where glyphs are not separated in cursive script.

OCR is generally an "off-line" process, which analyses a static document. Handwriting movement analysis can be used as input to handwriting recognition. Instead of merely using the shapes of glyphs and words, this technique is able to capture motions, such as the order in which segments are drawn, the direction, and the pattern of putting the pen down and lifting it. This additional information can make the end-to-end process more accurate. This technology is also known as "online character recognition", "dynamic character recognition", "real-time character recognition", and "intelligent character recognition".



## 7.2.5 Techniques

Notes

### Pre-processing

OCR software often “pre-processes” images to improve the chances of successful recognition. Techniques include:

- **De-skew:** If the document was not aligned properly when scanned, it may need to be tilted a few degrees clockwise or counter clockwise in order to make lines of text perfectly horizontal or vertical.
- **Despeckle:** Remove positive and negative spots, smoothing edges.
- **Binarization:** Convert an image from colour or grey scale to black-and-white (called a “binary image” because there are two colours). In some cases, this is necessary for the character recognition algorithm; in other cases, the algorithm performs better on the original image and so this step is skipped.
- **Line removal:** Cleans up non-glyph boxes and lines.
- **Layout analysis or “zoning”:** Identifies columns, paragraphs, captions, etc. as distinct blocks. Especially important in multi-column layouts and tables.
- **Line and word detection:** Establishes baseline for word and character shapes, separates words if necessary.
- **Character isolation or “segmentation”:** For per-character OCR, multiple characters that are connected due to image artefacts must be separated; single characters that are broken into multiple pieces due to artefacts must be connected.
- **Normalize aspect ratio and scale:** The aspect ratio is the ratio of the width of a shape to its height when the width is larger than the height, i.e. the shape is positioned as a “landscape” rather than “portrait”. The scale ratio of a model represents the proportional ratio of a linear dimension of the model to the same feature of the original. So, aspect ratio and scale should be normalized.

Segmentation of fixed-pitch fonts is accomplished relatively simply by aligning the image to a uniform grid based on where vertical grid lines will least often intersect black areas. For proportional fonts, more sophisticated techniques are needed because whitespace between letters can sometimes be greater than that between words, and vertical lines can intersect more than one character.

### Character Recognition

There are two basic types of core OCR algorithm, which may produce a ranked list of candidate characters.

Matrix matching involves comparing an image to a stored glyph on a pixel-by-pixel basis; it is also known as “pattern matching” or “pattern recognition”. This relies on the input glyph being correctly isolated from the rest of the image, and on the stored glyph being in a similar font and at the same scale. This technique works best with typewritten text and does not work well when new fonts are encountered. This is the technique the early physical photocell-based OCR implemented, rather directly.

Feature extraction decomposes glyphs into “features” like lines, closed loops, line direction, and line intersections. These are compared with an abstract vector-like representation of a character, which might reduce to one or more glyph prototypes. General techniques of feature detection in computer vision are applicable to this type of OCR, which is commonly seen in “intelligent” handwriting recognition and indeed most modern OCR software. Nearest neighbour

## Notes

classifiers such as the k-nearest neighbours algorithm are used to compare image features with stored glyph features and choose the nearest match.

Software such as Cuneiform and Tesseract use a two-pass approach to character recognition. The second pass is known as “adaptive recognition” and uses the letter shapes recognized with high confidence on the first pass to better recognize the remaining letters on the second pass. This is advantageous for unusual fonts or low-quality scans where the font is distorted (e.g. blurred or faded).

### Post-Processing

OCR accuracy can be increased if the output is constrained by a lexicon – a list of words that are allowed to occur in a document. This might be, for example, all the words in the English language, or a more technical lexicon for a specific field. This technique can be problematic if the document contains words not in the lexicon, like proper nouns. Tesseract uses its dictionary to influence the character segmentation step, for improved accuracy.

The output stream may be a plain text stream or file of characters, but more sophisticated OCR systems can preserve the original layout of the page and produce.



*Example:* An annotated PDF that includes both the original image of the page and a searchable textual representation.

“Near-neighbour analysis” can make use of co-occurrence frequencies to correct errors, by noting that certain words are often seen together.



*Example:* “Washington, D.C.” is generally far more common in English than “Washington DOC”.

Knowledge of the grammar of the language being scanned can also help determine if a word is likely to be a verb or a noun, for example, allowing greater accuracy.

### Application – Specific Optimizations

In recent years, the major OCR technology providers began to tweak OCR systems to better deal with specific types of input. Beyond an application-specific lexicon, better performance can be had by taking into account business rules, standard expression, or rich information contained in colour images. This strategy is called “Application-Oriented OCR” or “Customized OCR”, and has been applied to OCR of license plates, business cards, invoices, screenshots, ID cards, driver licenses, and automobile manufacturing.

#### 7.2.6 Advantages of OCR

From speedy searches to saving space, there are numerous benefits to scanning your documents with OCR software:

- **No more retyping:** If you lose or accidentally erase an important digital file, such as a proposal or invoice, but still have a hard copy, you can easily replace it in your digital filing system by using OCR software to scan the paper original or most recent draft.
- **Quick digital searches:** OCR software converts scanned text into a word processing file, giving you the opportunity to search for specific documents using a keyword or phrase.



*Example:* You could effortlessly search hundreds of invoices and locate a specific name or account in moments, without having to thumb through extensive files.

- **Edit text:** Once you've scanned your document using OCR, you have the option to edit the text within a word processing program of your choice. Scan items that may need to be updated in the future to help expedite the editing process. It will be:
  - ❖ Typed family recipes
  - ❖ Rental agreements
  - ❖ Resumes
  - ❖ Contracts
- **Save space:** Free up storage space by scanning paper documents and hauling the originals off to storage. You can easily turn a filing cabinet worth of information into editable digital files, and create a backup system consisting of a single CD.
- **Accessibility:** OCR software is a useful Accessibility or Ease of Access tool. Vision impaired PC users can scan books, magazines, incoming faxes, or other documents into word processing programs to be used in conjunction with a computer voice-over utility.

### How to Choose the Right Software

- **Usability:** Should have a capability to deal with a variety of text, images video and sound formats with precision and ease.
- **Animations:** Should have wide ranging capabilities in terms of interactive simulations, media support, animated buttons, illustrations, maps, etc.
- **Smoothness:** Should have anti-aliasing feature, meaning that all letter and image edges are smooth.
- **Integration:** Should have integration capabilities with a wide range of software used for different jobs like Real, ActiveX, Shockwave, Flash, QuickTime, Photoshop and other applications.
- **Delivery:** Should be able to develop one piece of content for delivery on different media types.
- **User friendliness:** Should be the easiest, most versatile, and have the most pre-built models.
- **Clientele:** Should have applications for instructional designers, subject matter experts, training developers and others.

### Self Assessment

State whether the following statements are true or false:

1. ICR stands for Internet Character Recognition.
2. OCR software turns bitmapped characters into electronically recognizable ASCII text.
3. Adobe Photoshop is a word processor.
4. A text editor cannot change configuration files and programming language source code.
5. With the help of word processor you can make changes without retyping the entire document.

### 7.3 Painting and Drawing Tools

Working with painting and drawing software will challenge your perceptions of painting and drawing, and shape your own vision as an artist. Explore the traditions of painting and drawing, while taking bold new risks as an artist by working with various painting and drawing software. Celebrates the power of painting and the mark of the human hand, which are our traditional methods and craft, while also embracing an innovative and expanded definition of the discipline.

Given below are various art-oriented software programs designed especially for painting, drawing, colouring, and creating original art work. Although some of them also offers tools for working with pre-existing images, the emphasis is on art and the creation process. Most of them have tools to mimic traditional artistic media such as oils, water colours, acrylics, pencils, markers, crayons, chalk, pastels, and felt pens. Many of them also offer a variety of unusual, non-traditional tools.

- **Corel Painter (Windows and Macintosh):** Corel Painter is like a well-stocked artist's studio, without the mess. With textured surfaces, brushes, and tools, you can mimic painting and drawing with chalk, pastels, water colours, oils, crayons, pencil, felt pens, ink, and more. Painter also offers non-traditional tools such as image hose, pattern pens, cloners, and special effects. While its strong point is its artistic toolset, Painter also offers features for photo enhancement, Web graphics creation, animation, and working with text.
- **SketchBook Pro (Windows and Macintosh):** Autodesk SketchBook Pro (formerly from Alias) is an innovative freehand drawing and painting program for Windows and Macintosh. Although it does not offer the same variety as other artistic software, it is extremely easy to learn and use. If you've been frustrated or overwhelmed by the complexity of other painting/drawing programs, SketchBook Pro is a great way to sketch out ideas, annotate images, and explore computer-based drawing. Sketchbook is also available as a mobile app for iOS and Android.
- **Corel Painter Essentials (Windows and Macintosh):** Corel Painter Essentials is a simplified, home-user version of Corel Painter professional-level art software. It's designed to help beginners or non-artists create digital art and turn photos into art work. Although it is certainly more limited than Painter, Essentials has a worthy set of tools and effects to allow users to explore digital art without being overwhelmed by too many options. It also provides an ideal upgrade path to Painter; buying Painter Essentials and then upgrading to Painter can often cost less than buying Painter outright.
- **Drawing for Children-Free (Windows):** Drawing for Children is a free drawing application designed specifically for children. It would be easy to think that any very basic drawing application would be ideal for children, but there's more to Drawing for Children than that. Tools and features have been included that offer a wide range of ways for users to draw, but they're not complicated by having various different options for changing the way that a tool works.

#### **Why Buy Drawing Software?**

Every Windows operating system includes a standard paint application, so you may wonder why you would need to buy drawing software. You will find the answer as soon as you attempt to use a basic paint program for advanced drawing. No serious or aspiring artist would be satisfied with software that only has basic pencil, eraser, fill and spray-can tools. Several art software programs give you the tools that professional illustrator applications offer at a fraction of the cost.

When you are looking to buy sketching software, you likely want powerful tools and features that will assist you in creating professional-looking art. These art applications provide a great starting place for up-and-coming digital artists, and some software is good enough to use on a more professional level. Most drawing software allows you to create layers and vector images, and whether you skew and resize these images will not affect their clarity. These programs have multiple options to customize brushes and colours as well.



*Notes* If you're looking for the best drawing software, we recommend Xara Photo & Graphic Designer, DrawPlus and Sketchbook Pro.

### Drawing Software: What to Look For

Every company that makes drawing software has a slightly different idea about what to include. Some focus on replicating natural artistic methods and give you advanced and custom brushes like you would use on canvas. Other drawing software centres on graphic design and photo editing and is focused on manipulating drawings once you've done a sketch or uploaded existing art. The basic tools in both are a select tool, pencil, eraser, fill and colour palette. Beyond that, the experience varies, so we have rated the top products using the following criteria.

- **Tools:** Every drawing program includes standard pencil, text and gradient tools. The added advantages of each application are what helps add superior quality and a unique look to each piece of art. These extras range from 3D vector effects to the ability to trace uploaded pictures and images.
- **Features:** Many of these drawing applications have powerful vector-editing tools that resemble the tools and features in professional-grade graphic design applications. Each of the drawing applications we reviewed have unique features that you can utilize to create different types of professional-looking art. During our evaluation, we found features in some applications that are not as advanced or functional as they could be, which is also important for you to know.
- **File Compatibility:** For this level of drawing software, file compatibility is very important. Many professionals are not as concerned about file compatibility because they know how to manipulate files and save them in the formats they need. If you are not an expert with drawing applications, it is often best to choose drawing software that allows you to export and import as many file types as possible. This way, you can always import, save and export your image files in the format that you need to use.
- **Help and Support:** Software developers provide a variety of methods for you to obtain assistance with your art software, whether you have questions about how to install the software or general questions about the application. The number of support options that are available to help you learn how to use the application are important, as are the types of available assistance. These may include telephone, email and live chat support, video tutorials, FAQs and online forums.

Drawing software will help you improve your technique with digital media and maximize your graphic design potential. Using the tools and features in these sketching programs will give you a taste of the capabilities of professional-grade art software. With sketch software, you can improve your artistic skills and elevate your understanding of digital art.

Prepare five graphic images using a paint or drawing program. Be sure to include a variety of colours and contrasts. Add text to the images. Use small text, large text, text with serifs, bold text, and text in contrasting and similar colours. Add drop shadows. Add boxes and other shapes to the images, in various weights.

Notes

**Self Assessment**

State whether the following statements are true or false:

6. Every drawing program includes standard pencil, text and gradient tools.
7. Drawing for Children is a not free drawing application designed specifically for children.
8. Autodesk SketchBook Pro is an innovative freehand drawing and painting program for Windows and Macintosh.
9. Xara Photo & Graphic Designer and DrawPlus are two of the best drawing software.
10. If you are not an expert with drawing applications, it is often best to choose drawing software that does not allow you to export and import as many file types as possible.



Case Study

**Oldest Unheard Text Editors**

If you still think that Microsoft Notepad or EMacs were the first Text Editors ever known to the mankind then you are so incorrect. There had been Text Editors even before them, some were Free and others were either licensed under some License or were proprietary.

History of Text Editors starts from early 70s era. With very basic functionality, those editors did not have many features to format your text. Time has really changed now. Editors like XEmacs and Notepad++ are one of the favourite text editors due to their exhaustive features, customizations and support for extensibility.

Below are the list of 9 oldest Text Editors (sans Emacs and Notepad) and brief history about them.

**Ed**

Ed is one of the oldest and standard Text editors of UNIX operating system. Ed is the first Text Editor to have implementation of regular expressions. Without any visual feedback, its error messages were in the form of a question mark ("?"). With coming of so many advance editors, nobody uses Ed these days but sometimes it is very useful when there is no support available for any other Text Editors or you are writing some simple shell script.

**JOE**

JOE is an acronym for Joe's Own Editor. It is a terminal based text editor for UNIX. It was the first text editor which incorporated built-in help system which had a reminder on the screen of how to use it. In many Linux distributions of that era, JOE was the default editor which is the reason why it was so popular then. The editor is still available with advanced features. You can download it from its source forge project page.

**SlickEdit**

SlickEdit was the first advanced editor that supported features like syntax highlighting, refactoring code and keyboard shortcuts customizations. It is a cross-browser platform which is still available with much more advanced features. Latest version of SlickEdit was released in March 2009.

*Contd....*

**CRiSP Editor**

CRiSP is yet another cross platform text editor popular among programmers. Early features of CRiSP also had syntax highlighting, keyboard bindings and code navigation and refactoring features. CRiSP can also handle huge multi-gigabytes of files. The editor is still very much available for download with improvements.

**Epsilon**

Epsilon was the popular text editor among programmers. It was a shadow of Emacs with its default key bindings and layout too. Epsilon is supported on MSDOS, Windows, Linux, FreeBSD and OS/2 and has support for Unicode too.

**VEDIT**

VEDIT is a text editor for MS Windows and MS DOS. It was one of the first Visual Text editor which could also handle files of huge size. Since it is written in Assembly Language VEDIT is extremely fast Text editor when compared to other editors. It also supported editing of remote files via FTP and was able to detect DOS, Unix and Mac files before editing them. VEDIT is also commercial software.

**Sam Editor**

Sam was the first editor that supported multiple files editing. Initially it was designed for UNIX terminals and was later ported to other systems too. Sam is the favorite text editor of many distinguished people like Bjarne Stroustrup, Brian Kernigham and Ken Thompson (Ed editor).

**NEdit**

NEdit stands for Nirvana Editor. It was another popular visual text editors as well as source code editor used by programmers. Its interface quite resembles to Mac and Windows editors. It was one of the first editors that supported automatic indentation on the basis of code language that you are editing.

**Mined**

Mined stands for MINIX-Editor. Mined is a terminal based editor that is available for Unix, Linux, Windows and MSDOS. It was one of the first text editors to support Unicode inside a terminal. It also had implementation of smart quotes and had extensive support for Unicode

**Questions:**

1. Critically analyse the early text editors.
2. What was the main cause for developing the text editors?

Source: <http://tech-buzz.net/2009/05/23/9-oldest-text-editors-you-probably-have-never-heard-of/>

**7.4 Summary**

- The most popular word processor is Microsoft Word, which is often purchased as part of Microsoft's Office suite.
- OCR software turns bitmapped characters into electronically recognizable ASCII text.
- Most OCR applications claim about 99 per cent accuracy when reading 8- to 36-point printed characters at 300 dpi.

**Notes**

- OCR allows users to quickly automate data capture from forms, eliminate keystrokes to reduce data entry costs and still maintain the high level of accuracy required in forms processing applications.
- OCR accuracy can be increased if the output is constrained by a lexicon – a list of words that are allowed to occur in a document.
- Drawing software will help you improve your technique with digital media and maximize your graphic design potential.

### **7.5 Keywords**

*Intelligent Character Recognition (ICR):* A software used to describe the process of interpreting image data, in particular alphanumeric text.

*Intelligent Word Recognition (IWR):* Targets handwritten print script or cursive text, one word at a time.

*Optophone:* A handheld scanner that when moved across a printed page, produced tones that corresponded to specific letters or characters.

*Word Processor:* A computer program that provides special capabilities beyond that of a text editor such as the WordPad program.

### **7.6 Review Questions**

1. What is the importance of software in multimedia?
2. Write in detail about painting and drawing software.
3. Importance of drawing software in today's time. Discuss.
4. Explain the process of downloading a drawing and painting software.
5. Describe text editing and word processing tools.
6. What are the benefits of OCR software?
7. Explain in detail the pre-processing technique in OCR.
8. What are the things one should keep in mind before buying a software?
9. What is a text editor? Elaborate.
10. What do you know about OCR?

### **Answers: Self Assessment**

- |          |           |
|----------|-----------|
| 1. False | 2. True   |
| 3. False | 4. False  |
| 5. True  | 6. True   |
| 7. False | 8. True   |
| 9. True  | 10. False |



## 7.7 Further Readings

Notes



Books

Chauhan R K, *Computer Graphics & Multimedia*

Frederick P. Brooks, Jr., Kenan Professor of Computer Science, *The Mythical Man-Month: Essays in Software Engineering*, University of North Carolina at Chapel Hill.

K. Andleigh and K. Thakkar, *Multimedia System Design*, PHI, PTR.

Steve Rimmer (2000), *Advanced Multimedia Programming*, MHI.

Tay Vaughan, *Multimedia Making it work*, Seventh Edition, Tata McGraw-Hill Education Private Ltd.



Online links

<http://cemca.org.in/ckfinder/userfiles/files/Section3.pdf>

<http://nora.lis.uiuc.edu:3030/companion/view?docId=blackwell/9781405103213/9781405103213.xml&doc.view=print&chunk.id=ss1-2-10&toc.depth=1&toc.id=0>

[http://users.mct.open.ac.uk/yr258/papers/Rogers\\_Scaife98.pdf](http://users.mct.open.ac.uk/yr258/papers/Rogers_Scaife98.pdf)

<http://www.icheg.org/icheg-game-history/timeline/>

<http://www.ict.griffith.edu.au/teaching/1611ICT/mm1alectures/111/Writing%20For%20Multimedia%20Great%20Moments%20In%20Multimedia%20History.htm>

## Unit 8: Fundamental of Animations

### CONTENTS

Objectives

Introduction

- 8.1 Principles of Animation
- 8.2 Animation Fundamentals
  - 8.2.1 Character Model Sheet
  - 8.2.2 Frames
  - 8.2.3 Cycles
  - 8.2.4 Storyboards
- 8.3 Animation Techniques
  - 8.3.1 Cel Animation
  - 8.3.2 Computer Animation
- 8.4 Animation File Formats
- 8.5 Summary
- 8.6 Keywords
- 8.7 Review Questions
- 8.8 Further Readings

### Objectives

After studying this unit, you will be able to:

- Describe principles of animation
- Explain animation fundamentals
- Understand animation techniques
- Describe animation file formats

### Introduction

Computer animation or CGI animation is the process used for generating animated images by using computer graphics. The more general term computer-generated imagery encompasses both static scenes and dynamic images, while computer animation only refers to moving images.

Modern computer animation usually uses 3D computer graphics, although 2D computer graphics are still used for stylistic, low bandwidth, and faster real-time renderings. Sometimes the target of the animation is the computer itself, but sometimes the target is another medium, such as film.

Computer animation is essentially a digital successor to the stop motion techniques used in traditional animation with 3D models and frame-by-frame animation of 2D illustrations. Computer generated animations are more controllable than other more physically based

processes, such as constructing miniatures for effects shots or hiring extras for crowd scenes, and because it allows the creation of images that would not be feasible using any other technology. It can also allow a single graphic artist to produce such content without the use of actors, expensive set pieces, or props.

## 8.1 Principles of Animation

These principles of animation became the generally accepted techniques according to Don Graham who worked with Walt Disney in founding the industry that you see today. Classes for his animators were set up under the instruction of Graham. There is no short cut for skills and knowledge. Each technique was named and they became known as the fundamental principles of animation that are listed below:

### 1. *Squash and Stretch*

Figure 8.1: Example showing Squash and Stretch

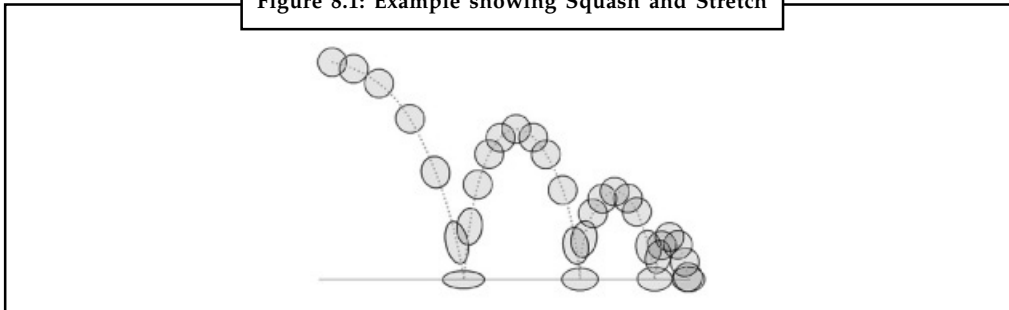

This action gives the illusion of weight and volume to a character as it moves. Also squash and stretch is useful in animating dialogue and doing facial expressions. How extreme the use of squash and stretch is, depends on what is required in animating the scene. Usually it's broader in a short style of picture and subtler in a feature. It is used in all forms of character animation from a bouncing ball to the body weight of a person walking. This is the most important element you will be required to master and will be used often.



*Example:* If a rubber ball bounces and hits the ground it will tend to flatten when it hits. This is the squash principle. As it starts to bounce up it will stretch in the direction it is going. Squash and stretch was also initially done to prevent strobing due to lack of motion blur.

### 2. *Anticipation*

Figure 8.2: Character showing Anticipation

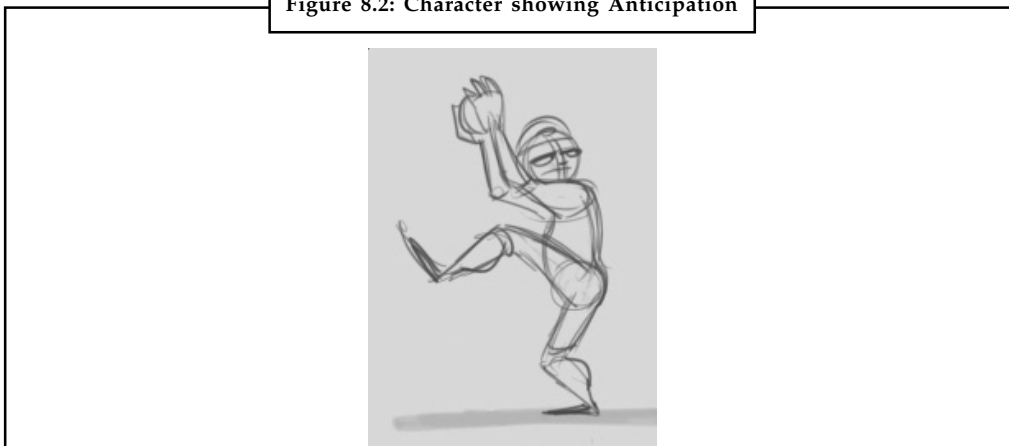

Notes

This movement prepares the audience for a major action the character is about to perform, such as, starting to run, jump or change expression. A dancer does not just leap off the floor. A backwards motion occurs before the forward action is executed. The backward motion is the anticipation. A comic effect can be done by not using anticipation after a series of gags that used anticipation. Almost all real action has major or minor anticipation such as a pitcher’s wind-up or a golfers’ back swing. Feature animation is often less broad than short animation unless a scene requires it to develop a characters personality.



*Example:* A character zips off screen leaving a puff of smoke. Usually just before the zip, there is a pose where the characters raises a leg and bends both arms as if he’s about to run. That is the anticipation pose for the off screen run.

3. *Staging*

Figure 8.3: Example showing the difference in Poor and Good Staging

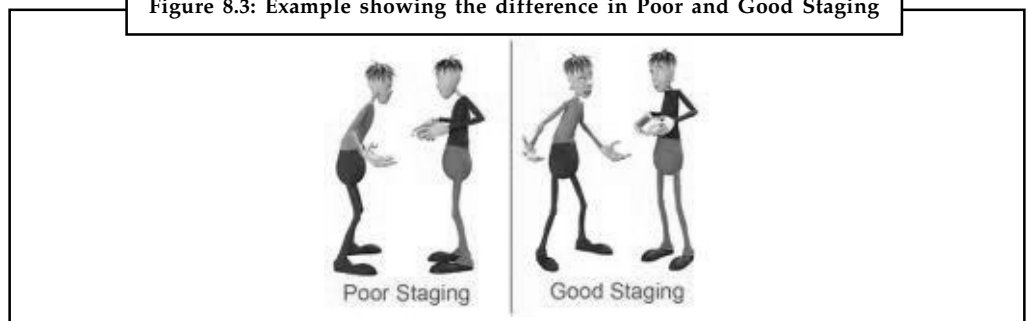

A pose or action should clearly communicate to the audience the attitude, mood, reaction or idea of the character as it relates to the story and continuity of the story line. The effective use of long, medium, or close up shots, as well as camera angles also helps in telling the story. There is a limited amount of time in a film, so each sequence, scene and frame of film must relate to the overall story. Do not confuse the audience with too many actions at once. Use one action clearly stated to get the idea across, unless you are animating a scene that is to depict clutter and confusion. Staging directs the audience’s attention to the story or idea being told. Care must be taken in background design so it isn’t obscuring the animation or competing with it due to excess detail behind the animation. Background and animation should work together as a pictorial unit in a scene.



*Example:* If you are staging a sad pose you may have the character hunched over with his arms hanging at his sides and a high camera angle... but if you give him this big grin on his face it would not fit with the rest of the pose.

4. *Straight Ahead and Pose-To-Pose Animation*

Figure 8.4: Example showing Straight Ahead and Pose-to-Pose Animation

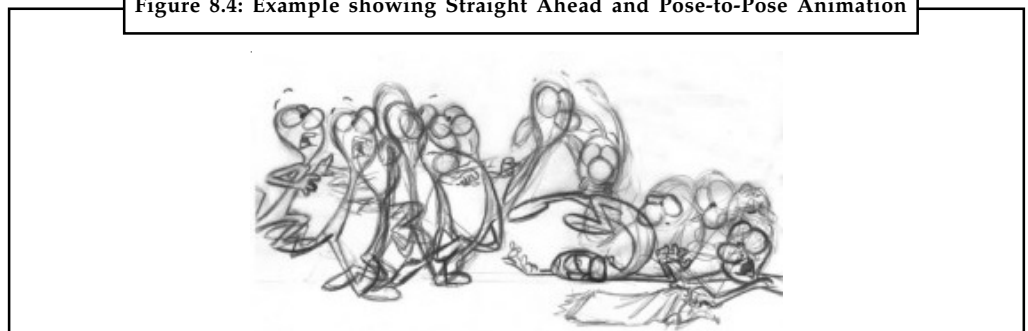

Straight ahead animation starts at the first drawing and works drawing to drawing to the end of a scene. You can lose size, volume, and proportions with this method, but it does have spontaneity and freshness. Fast, wild action scenes are done this way. Pose-to-Pose is more planned out and charted with key drawings done at intervals throughout the scene. Size, volumes, and proportions are controlled better this way, as is the action. The lead animator will turn charting and keys over to his assistant. An assistant can be better used with this method so that the animator doesn't have to draw every drawing in a scene. An animator can do more scenes this way and concentrate on the planning of the animation. Many scenes use a bit of both methods of animation.



*Example:* The animator draws the first frame of the animation, and then draws the second, and so on until the sequence is complete. In this way, there is one drawing or image per frame that the animator has setup.

#### 5. Follow through and Overlapping Action

Figure 8.5: Example of Follow through and Overlapping Action

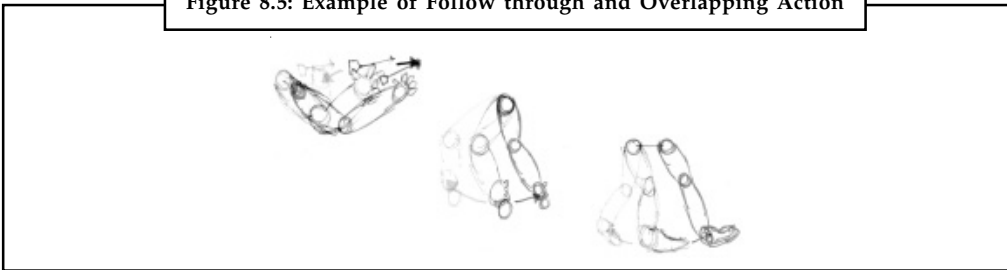

When the main body of the character stops all other parts continue to catch up to the main mass of the character, such as arms, long hair, clothing, coat tails or a dress, floppy ears or a long tail (these follow the path of action). Nothing stops all at once. This is follow through. Overlapping action is when the character changes direction while his clothes or hair continues forward. The character is going in a new direction, to be followed, a number of frames later, by his clothes in the new direction. "DRAG," in animation, for example, would be when Goofy starts to run, but his head, ears, upper body, and clothes do not keep up with his legs. In features, this type of action is done more subtly.



*Example:* When Snow White starts to dance, her dress does not begin to move with her immediately but catches up a few frames later. Long hair and animal tail will also be handled in the same manner. Timing becomes critical to the effectiveness of drag and the overlapping action.

#### 6. Slow-out and Slow-in

Figure 8.6: Example of Slow-out and Slow-in

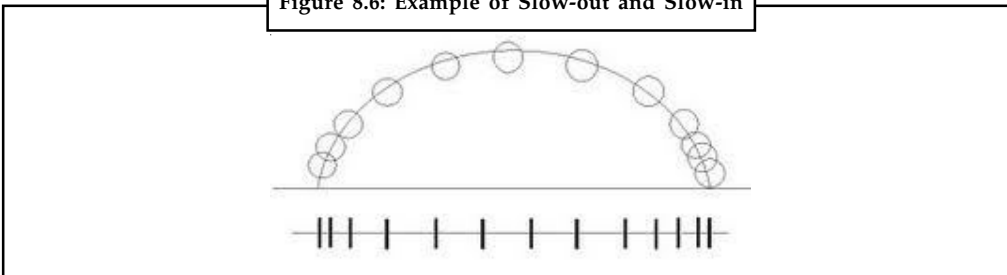

As action starts, we have more drawings near the starting pose, one or two in the middle, and more drawings near the next pose. Fewer drawings make the action faster and more

Notes

drawings make the action slower. Slow-ins and slow-outs soften the action, making it more life-like. For a gag action, we may omit some slow-out or slow-ins for shock appeal or the surprise element. This will give more snap to the scene.



*Example:* A bouncing ball tends to have a lot of ease in and out when at the top of its bounce. As it goes up, gravity affects it and slows down (Ease In), then it starts its downward motion more and more rapidly (Ease Out), until it hits the ground.



*Caution* This does not mean slow movement. This really means keep the in-between frames close to each extreme.

7. Arcs

Figure 8.7: Character showing Arcs

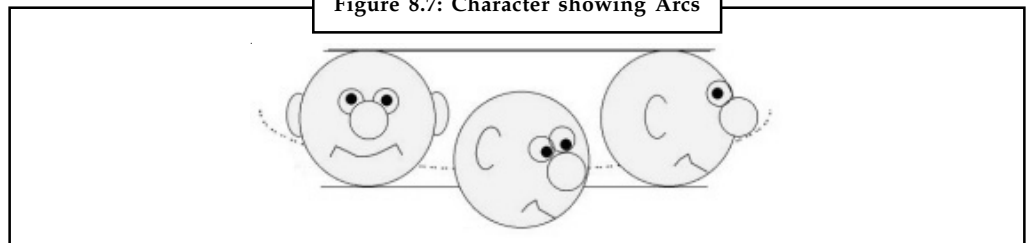

All actions, with few exceptions (such as the animation of a mechanical device), follow an arc or slightly circular path. This is especially true of the human figure and the action of animals. Arcs give animation a more natural action and better flow. Think of natural movements in the terms of a pendulum swinging. All arm movement, head turns and even eye movements are executed on an arcs.



*Notes* Even gross body movements when you walk somewhere tend not be perfectly straight. When a hand/arm reaches out to reach something, it tends to move in an arc.

8. Secondary Action

Figure 8.8: Character showing Secondary Action

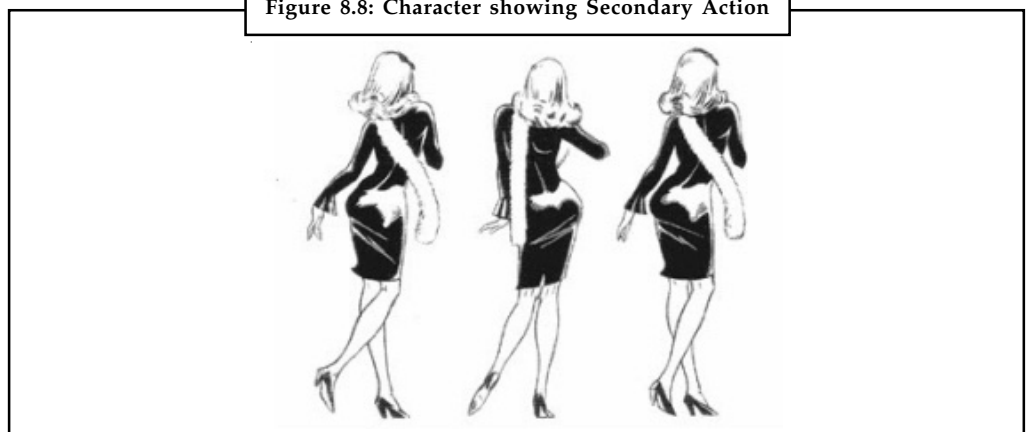

This action adds to and enriches the main action and adds more dimension to the character animation, supplementing and/or re-enforcing the main action.



*Example:* A character is angrily walking toward another character. The walk is forceful, aggressive, and forward leaning. The leg action is just short of a stomping walk. The secondary action is a few strong gestures of the arms working with the walk.

Also, the possibility of dialogue being delivered at the same time with tilts and turns of the head to accentuate the walk and dialogue, but not so much as to distract from the walk action. All of these actions should work together in support of one another. Think of the walk as the primary action and arm swings, head bounce and all other actions of the body as secondary or supporting action. A moving hold is the idea that a character is never completely still, they blink or shift weight, etc.

#### 9. Timing

Figure 8.9: Example showing Timing

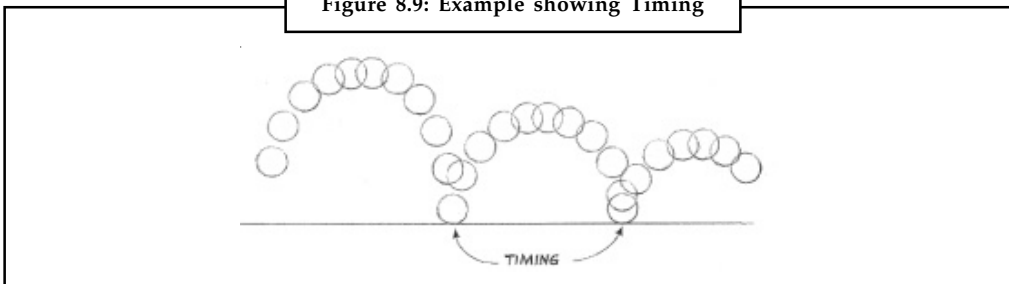

Expertise in timing comes best with experience and personal experimentation, using the trial and error method in refining technique. The basics are: more drawings between poses slow and smooth the action. Fewer drawings make the action faster and crisper. A variety of slow and fast timing within a scene adds texture and interest to the movement. Most animation is done on twos (one drawing photographed on two frames of film) or on ones (one drawing photographed on each frame of film). Twos are used most of the time, and ones are used during camera moves such as trucks, pans and occasionally for subtle and quick dialogue animation. Also, there is timing in the acting of a character to establish mood, emotion, and reaction to another character or to a situation. Studying movement of actors and performers on stage and in films is useful when animating human or animal characters. This frame-by-frame examination of film footage will aid you in understanding timing for animation. This is a great way to learn from the others.

#### 10. Exaggeration

Figure 8.10: Character showing Exaggeration

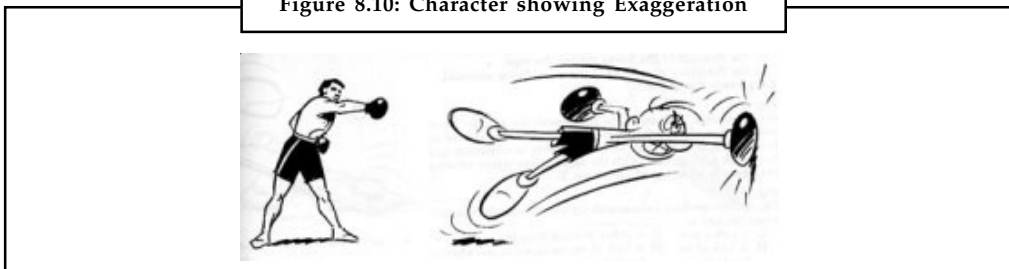

Exaggeration is not extreme distortion of a drawing or extremely broad, violent action all the time. It's like a caricature of facial features, expressions, poses, attitudes and actions. Action traced from live action film can be accurate, but stiff and mechanical. In feature animation, a character must move more broadly to look natural. The same is true of facial expressions, but the action should not be as broad as in a short cartoon style. Exaggeration in a walk or an eye movement or even a head turn will give your film more appeal. Use

Notes

good taste and common sense to keep from becoming too theatrical and excessively animated

11. *Solid Drawing*

Figure 8.11: Character showing Solid Drawing



The basic principles of drawing form, weight, volume solidity and the illusion of three dimensions apply to animation as it does to academic drawing. The way you draw cartoons, you draw in the classical sense, using pencil sketches and drawings for reproduction of life. You transform these into color and movement giving the characters the illusion of three-and four-dimensional life. Three-dimensional is movement in space. The fourth dimension is movement in time.

12. *Appeal*

Figure 8.12: Example showing Appeal



A live performer has charisma. An animated character has appeal. Appealing animation does not mean just being cute and cuddly. All characters have to have appeal whether they are heroic, villainous, comic or cute. Appeal, as you will use it, includes an easy to read design, clear drawing, and personality development that will capture and involve the audience's interest. Early cartoons were basically a series of gags strung together on a main theme. Over the years, the artists have learned that to produce a feature there was a need for story continuity, character development and a higher quality of artwork throughout the entire production. Like all forms of story-telling, the feature has to appeal to the mind as well as to the eye.





*Did u know?* The Twelve Basic Principles of Animation is a set of principles of animation introduced by the Disney animators Ollie Johnston and Frank Thomas in their 1981 book: *The Illusion of Life: Disney Animation*.

## Self Assessment

Choose the correct option to answer the following:

1. This action gives the illusion of weight and volume to a character as it moves.
  - (a) Squash and Stretch
  - (b) Anticipation
  - (c) Slow-out and Slow-in
  - (d) Secondary Action
2. This movement prepares the audience for a major action the character is about to perform, such as, starting to run, jump or change expression.
  - (a) Squash and Stretch
  - (b) Slow-out and Slow-in
  - (c) Anticipation
  - (d) Secondary Action
3. A pose or action should clearly communicate to the audience the attitude, mood, reaction or idea of the character as it relates to the story and continuity of the story line.
  - (a) Staging
  - (b) Slow-out and Slow-in
  - (c) Anticipation
  - (d) Secondary Action
4. Straight ahead animation starts at the first drawing and works drawing to drawing to the end of a scene.
  - (a) Staging
  - (b) Follow through and Overlapping Action
  - (c) Anticipation
  - (d) Straight Ahead and Pose-To-Pose Animation
5. When the main body of the character stops all other parts continue to catch up to the main mass of the character, such as arms, long hair, clothing, coat tails or a dress, floppy ears or a long tail (these follow the path of action).
  - (a) Squash and Stretch
  - (b) Anticipation
  - (c) Follow through and Overlapping Action
  - (d) Secondary Action
6. As action starts, we have more drawings near the starting pose, one or two in the middle, and more drawings near the next pose.
  - (a) Solid Drawing
  - (b) Appeal
  - (c) Exaggeration
  - (d) Slow-out and Slow-in
7. All actions, with few exceptions (such as the animation of a mechanical device), follow ..... or slightly circular path.
  - (a) Arcs
  - (b) Appeal
  - (c) Timing
  - (d) Slow-out and Slow-in

**Notes**

8. This action adds to and enriches the main action and adds more dimension to the character animation, supplementing and/or re-enforcing the main action.
  - (a) Appeal
  - (b) Secondary Action
  - (c) Timing
  - (d) Slow-out and Slow-in
9. Expertise in ..... comes best with experience and personal experimentation, using the trial and error method in refining technique.
  - (a) Timing
  - (b) Solid Drawing
  - (c) Exaggeration
  - (d) Squash and Stretch
10. This is not extreme distortion of a drawing or extremely broad, violent action all the time. It's like a caricature of facial features, expressions, poses, attitudes and actions.
  - (a) Appeal
  - (b) Solid Drawing
  - (c) Exaggeration
  - (d) Squash and Stretch
11. The basic principles of drawing form, weight, volume solidity and the illusion of three dimensions apply to animation as it does to academic drawing.
  - (a) Appeal
  - (b) Solid Drawing
  - (c) Exaggeration
  - (d) Squash and Stretch
12. A live performer has charisma. An animated character has appeal. Appealing animation does not mean just being cute and cuddly.
  - (a) Secondary Action
  - (b) Timing
  - (c) Appeal
  - (d) Slow-out and Slow-in

## **8.2 Animation Fundamentals**

Using appropriate software and techniques, you can animate visual images in many ways. The simplest animations occur in two-dimensional (2-D) space; more complicated animations occur in an intermediate "2½-D" space where shadowing, highlights, and forced perspective provide an illusion of depth, the third dimension); and the most realistic animations occur in three-dimensional (3-D) space.

In 2-D space, the visual changes that bring an image alive occur on the flat Cartesian x and y axes of the screen. A blinking word, a color-cycling logo (where the colors of an image are rapidly altered according to a formula), a cel animation, or a button or tab that changes state on mouse rollover to let a user know it 2-D animations. These are simple and static, is active are all examples of not changing their position on the screen. Path animation in 2-D space increases the complexity of an animation and provides motion, changing the location of an image along a predetermined path (position) during a specified amount of time (speed). Authoring and presentation software such as Flash or PowerPoint provide user-friendly tools to compute position changes and redraw an image in a new location, allowing you to generate a bouncing ball or slide a corporate mascot onto the screen. Combining changes in an image with changes in its position allows you to "walk" your corporate mascot onto the stage. Changing its size from small to large as it walks on stage will give you a 3-D perception of distance.

In 2½-D animation, an illusion of depth (the z axis) is added to an image through shadowing and highlighting, but the image itself still rests on the flat x and y axes in two dimensions. Embossing, shadowing, beveling, and highlighting provide a sense of depth by raising an image or cutting

it into a background. Zaxwerks' 3D Invigorator ([www.zaxwerks.com](http://www.zaxwerks.com)), for example, provides 3-D effects for text and images and, while calling itself "3D," works within the 2-D space of image editors and drawing programs such as Adobe Illustrator, Photoshop, Fireworks, and After Effects.

In 3-D animation, software creates a virtual realm in three dimensions, and changes (motion) are calculated along all three axes (x, y, and z), allowing an image or object that itself is created with a front, back, sides, top, and bottom to move toward or away from the viewer, or, in this virtual space of light sources and points of view, allowing the viewer to wander around and get a look at all the object's parts from all angles. Such animations are typically rendered frame by frame by high-end 3-D animation programs such as NewTek's Lightwave or AutoDesk's Maya.



*Did u know?* Today, computers have taken the handwork out of the animation and rendering process, and commercial films such as Shrek, Coraline, Toy Story, and Avatar have utilized the power of computers.



*Notes* Before we had full-motion moving pictures, there was flipbooks. Flipbooks were small books with pages where small caricatures were drawn. As you flipped the books from front to back, the drawings looked as though they were animated. Some flipbooks came empty, and you could add your own drawings. Flipbooks gave the illusion that the cartoon character in the pages was actually moving before our eyes. This illusion is the cornerstone of animation.

### 8.2.1 Character Model Sheet

When designing a character for any particular animated medium (2D or 3D), the designer must consider what their design will look like from all angles and from all points of view. Although traditionally drawn animation essentially views everything with a two-dimensional view, one look at the very best of 2D character animation reveals that it is necessary to understand the character from numerous viewpoints, even for something as simple as an animated take or head turn. To ensure that the designer, the director, and the team of animators understand the full structure and nature of a particular character from all possible angles and perspectives, a character model sheet is created.

A model sheet is the blueprint of a character, defining its size, construction, and proportions. The model sheet traditionally must show the character from the three fundamental viewpoints—front, profile, and rear view—with sometimes a front three-quarter and a rear three-quarter view thrown in for good measure. A good model sheet will also define the head-height formula for that character and may even include close-up details of the character's features, such as hands, mouth, and feet. There can often be more than one model sheet per character, depending on the amount of construction detail required by the production team. Additional model sheets might also show specific attitude poses of the character, its relative size to other featured characters, and even mouth positions for vowels and consonants if lip-sync dialogue is anticipated. With Hollywood-level movie productions, it might also be advisable to create 3D clay models of the main characters, so animators can pick them up and view their shape and form from every conceivable angle. Anything that familiarizes the animator with the character is valuable when designing an animation character.

## Notes

Below is a Model Rotation – its purpose to show the character from all sides.

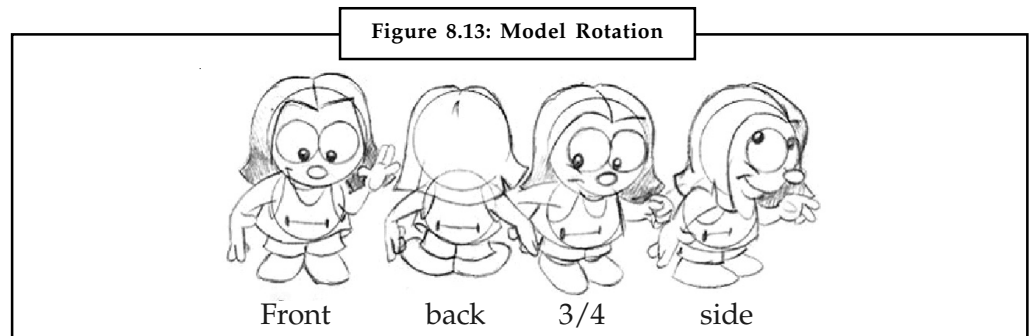

Observe how the character is drawing in the front, profile (side), 3/4 and back views. This is called a Character Rotation. For this, we use a simple shaped character. A simple shaped character uses one basic shape or FORM for the main body of character.



*Caution* Please keep in mind the dimensional aspects of your drawing – in other words what appear to be shapes are really 3D forms.

### 8.2.2 Frames

Before you can work with a frame, you must select it as the current frame. The contents of the current frame appear in the document window.

In the Animation panel (Photoshop Extended CS5) or Timeline panel (CS6), the current frame is indicated by a narrow border (inside the shaded selection highlight) around the frame thumbnail. Selected frames are indicated by a shaded highlight around the frame thumbnails.

The frame rate that you work at is a very important factor in the final quality of your animation. The frame rate determines how many frames per second are displayed when you playback your animation. If you set the frame rate too high, you have to produce too many drawings. If you set it too low, your animation will look choppy.

### 8.2.3 Cycles

There are lots of tricks that animators constantly use to cut down the amount of work to be done. Cycles of repeating action are just one of these ways – and whenever animators find an opportunity to include a cycle in a sequence, you can bet they will seize upon it.

Some of the very early cartoons were almost entirely based on cyclic actions, especially when it was discovered that animation could echo the rhythmic patterns found in music. Walt Disney's 1928 'Steamboat Willie' was the first sound cartoon to amaze audiences of the day with its close synchronism between image and sound. This relationship was exploited to the hilt, (giving rise to the term 'Mickey Mousing' – a sound track which follows exactly what the image is doing) as was the use of cyclic animation which took its cues from the repeated phases and beats of the musical score.



*Example:* Roll over the man on the bike to the right to make him ride. There are two cycles here. A 'resting' pant cycle consisting of only 2 drawings with asymmetrical timing, the breath-in pose being held slightly longer, and the riding cycle consisting of 5 drawings.

## 8.2.4 Storyboards

Notes

Once a concept or script is written for a film or animation, the next step is to make a storyboard. A storyboard visually tells the story of an animation panel by panel, kind of like a comic book.

Your storyboard will should convey some of the following information:

- What characters are in the frame, and how are they moving?
- What are the characters saying to each other, if anything?
- How much time has passed between the last frame of the storyboard and the current one?

### Self Assessment

Fill in the blanks:

13. In an intermediate ..... space where shadowing, highlights, and forced perspective provide an illusion of depth, the third dimension); and the most realistic animations occur in three-dimensional (3-D) space.
14. .... animation in 2-D space increases the complexity of an animation and provides motion, changing the location of an image along a predetermined path (position) during a specified amount of time (speed).
15. In ..... animation, software creates a virtual realm in three dimensions, and changes (motion) are calculated along all three axes (x, y, and z), allowing an image or object that itself is created with a front, back, sides, top, and bottom to move toward or away from the viewer, or, in this virtual space of light sources and points of view, allowing the viewer to wander around and get a look at all the object's parts from all angles.

## 8.3 Animation Techniques

When you create an animation, organise its execution into a series of logical steps. First, gather up in your mind all the activities you wish to provide in the animation. If it is complicated, you may wish to create a written script with a list of activities and required objects and then create a storyboard to visualise the animation. Choose the animation tool best suited for the job, and then build and tweak your sequences. This may include creating objects, planning their movements, texturing their surfaces, adding lights, experimenting with lighting effects, and positioning the camera or point of view. Allow plenty of time for this phase when you are experimenting and testing. Finally, post-process your animation, doing any special renderings and adding sound effects.

### 8.3.1 Cel Animation

The animation techniques made famous by Disney use a series of progressively different graphics or cels on each frame of movie film (which plays at 24 frames per second). A minute of animation may thus require as many as 1,440 separate frames, and each frame may be composed of many layers of cels. The term cel derives from the clear celluloid sheets that were used for drawing each frame, which have been replaced today by layers of digital imagery. Cels of famous animated cartoons have become sought-after, suitable-for-framing collector's items.

Cel animation artwork begins with keyframes (the first and last frame of an action). For example, when an animated figure of a woman walks across the screen, she balances the weight of her entire body on one foot and then the other in a series of falls and recoveries, with the opposite

**Notes**

foot and leg catching up to support the body. Thus the first keyframe to portray a single step might be the woman pitching her body weight forward off the left foot and leg, while her center of gravity shifts forward; the feet are close together, and she appears to be falling. The last keyframe might be the right foot and leg catching the body's fall, with the center of gravity now centered between the outstretched stride and the left and right feet positioned far apart. The series of frames in between the keyframes are drawn in a process called tweening. Tweening is an action that requires calculating the number of frames between keyframes and the path the action takes, and then actually sketching with pencil the series of progressively different outlines. As tweening progresses, the action sequence is checked by flipping through the frames. The penciled frames are assembled and then actually filmed as a pencil test to check smoothness, continuity, and timing.

When the pencil frames are satisfactory, they are permanently inked, photocopied onto cels, and given to artists who use acrylic colors to paint the details for each cel. Women were often preferred for this painstaking inking and painting work as they were deemed patient, neat, and had great eyes for detail. In the hands of a master, cel paint applied to the back of acetate can be simply flat and perfectly even, or it can produce beautiful and subtle effects, with feathered edges or smudges.



*Example:* The cels for each frame of our example of a walking woman—which may consist of a text title, a background, foreground, characters (with perhaps separate cels for a left arm, a right arm, legs, shoes, a body, and facial features)—are carefully registered and stacked. It is this composite that becomes the final photographed single frame in an animated movie.

To replicate natural motion, traditional cel animators often utilized “motion capture” by photographing a woman walking, a horse trotting, or a cat jumping to help visualize timings and movements. Today, animators use reflective sensors applied to a person, animal, or other object whose motion is to be captured. Cameras and computers convert the precise locations of the sensors into x, y, z coordinates and the data is rendered into 3-D surfaces moving over time.



*Task* Write a brief note on Cel Animation with suitable example.

### 8.3.2 Computer Animation

Computer animation programs typically employ the same logic and procedural concepts as cel animation and use the vocabulary of classic cel animation—terms such as layer, keyframe, and tweening. The primary difference among animation software programs is in how much must be drawn by the animator and how much is automatically generated by the software. In path-based 2-D and 2½-D animation, an animator simply creates an object (or imports an object as clip art) and describes a path for the object to follow. The computer software then takes over, actually creating the animation on the fly as the program is being viewed by your user. In cel-based 2-D animation, each frame of an animation is provided by the animator, and the frames are then composited (usually with some tweening help available from the software) into a single file of images to be played in sequence. ULead's GIF Animator ([www.ulead.com/ga](http://www.ulead.com/ga)) and Alchemy's GIF Construction Set Pro ([www.mindworkshop.com](http://www.mindworkshop.com)) simply string together your collection of frames.



*Caution* Overuse of animation and annoying visual effects can ruin a multimedia project.

**Self Assessment**

Notes

Fill in the blanks:

16. .... is an action that requires calculating the number of frames between keyframes and the path the action takes, and then actually sketching with pencil the series of progressively different outlines.
17. Nowadays animators use ..... applied to a person, animal, or other object whose motion is to be captured.
18. .... programs typically employ the same logic and procedural concepts as cel animation and use the vocabulary of classic cel animation—terms such as layer, keyframe, and tweening.

**8.4 Animation File Formats**

Some file formats are designed specifically to contain animations, so they can be ported among applications and platforms with the proper translators. Those formats include Director (.dir and .dcr), AnimatorPro (.fli and .flc), 3D Studio Max (.max), GIF89a (.gif), and Flash (.fla and .swf). Because file size is a critical factor when downloading animations to play on web pages, file compression is an essential part of preparing animation files for the Web. A Director's native movie file (.dir), for example, must be preprocessed and compressed into a proprietary Shockwave animation file (.dcr) for the Web. Compression for Director movies is as much as 75 percent or more with this tool, turning 100K files into 25K files and significantly speeding up download/display times on the Internet. Flash, widely used for web-based animation, makes extensive use of vector graphics to keep the post-compression file size at absolute minimums. As with Director, its native .fla files must be converted to Shockwave Flash files (.swf) in order to play on the Web. To view these animations within a web page, special plug-ins or players are required.



*Did u know?* Flash files are in the SWF format, traditionally called “ShockWave Flash” movies, “Flash movies,” or “Flash applications”, usually have a “.swf” file extension, and may be used in the form of a Web page plug-in, strictly “played” in a stand-alone Flash Player, or incorporated into a self-executing projector movie (with the .exe extension in Microsoft Windows).

In some cases, especially with 3-D animations, the individual rendered frames of an animation are put together into one of the standard digital video file containers, such as the Windows Audio Video Interleaved format (.avi), QuickTime (.qt, .mov), or Motion Picture Experts Group video (.mpeg or .mpg). These can be played using the media players shipped with computer operating systems.



*Task* Make a list of the various file formats used for animation.

**Self Assessment**

State whether the following statements are true or false:

19. Some file formats are designed specifically to contain animations, so they can restrict being ported among applications and platforms with the proper translators.

Notes

20. Especially with 3-D animations, the individual rendered frames of an animation are put together into one of the standard digital video file containers.



Case Study

## Process in the Animation Industry

– By Michael Comet (In his own words)

### About the Author

Michael Comet is currently a Rigger/T.D. at Blue Sky Studios in New York. Previously he worked as Video Team Lead Rigger and a 3D/Animator/Artist at Big Idea in Lombard, IL where he was an Animator/T.D. on the first three Penguins episodes, as well as several Veggie Tales Videos. Previously he was lead animator at the video game company Volition, Inc., where he animated most of the cinematic sequences for Descent: Freespace, and headed up much of the real-time character animation and cinematics R&D for their RPG title, "Summoner".

### Introduction

This article is an attempt to explain and illustrate how I usually go about my animation process, from idea to finished animation. If you haven't read it yet, you may also all working how I want. Layout is the first pass at this, which basically consists of me posing out the first frame, getting the set pieces made if needed, and framing the camera.

Once I'm happy with the layout of the shot, I'm ready to actually start animating. I'll look at my thumbnail sketches if I have any. I scrub the audio, and start putting in my key poses.

At work I've used "Step" keys. This way if I have a pose at frame 1, and then another pose at frame 20, I can just key those 2 frames. Everything "holds", there is no interpolation. At work we've termed this "pop-thru" (once again see Keith Lango's Tutorial as well), because everything seems to "pop" from one pose to another, because there are no in-between frames.

In MAX it's a bit of a pain to have to switch from step keys to linear keys and such, and in addition, I wanted to kind of get a feel for the timing just a tad more, especially since it is such a subtle clip. Therefore I opted to just use "Linear" key interpolation instead.

If I wanted a pose, once again on frame 1 and 20, what I would do is pose the first one on frame 1. Then figure out how long to hold the pose, say maybe I want 15 frames, so I'd go to frame 15, key all the character body parts there the exact same as on frame 1, and then go to frame 20 and key the second different pose. That way things stay the same and don't interpolate from 1-15, then there is a 5 frame change, and then the next pose on 20.

I pretty much continue this cycle of new pose, hold pose, then new pose, hold pose, until I am done. In some cases as shown here, I have some moving holds, because in reality the poses weren't supposed to pop. However as you notice, it is still very rough.

The idea at this "Blocking" stage is to simply get a quick picture of what the poses are, and what is happening in the shot to make sure it looks ok. The important aspect of this block stage are:

- Very quick to do. You're just putting in the basic poses.
- You can tell what is going on overall body-acting wise.

Contd....



- Interpolation and timing isn't too important right now, you're just doing a first shot at it.
- All parts of the body for each pose are keyed on the same frame. This makes it very easy to slide the keys/timing around later.

### Rough Animation

After I am pretty sure of my main poses, acting, and basic timing, I'll go in and start to tweak. Everything is still kept with "Linear" keys, so that I don't have to worry about splines interpolating wrong. At this point I'll start by adjusting the timing of the poses and their transitions.

Once I'm happy with that I'll also start to add more flourishes or sub-poses, which are really just the same pose, with some variations in them. I'll also add anticipation and follow through as I progress.

The idea here is even with linear keys, the animation should start to look more complete. If I key more than one part of the body, then I'll still make sure all the keys are on the same frame, i.e., there is no offsetting. But there is more detail and refinement in the poses, timing, and details.

I usually work in blocks, of 50-100 frames or so at a time. That way I can focus on just a small chunk, make it look good, then continue forward. Below are 3 clips of my progress through the rough stages.

Notice on the first Rough 1 movie, all I really did was start to add detail to the beginning of the clip, since I hadn't gotten farther yet. In the Rough 2 movie, things have been fleshed out pretty well. I don't usually do any facial animation so the face is hidden, although I did do a quick eye move to help me read what was going on. In Rough 3, I decided to push the poses a bit more, exaggerating some of the moves a little bit more extremely to add some variation.

The important things about the Rough stage are:

- Timing gets corrected.
- Poses get refined, in-between poses are added. Anticipation and follow through poses are used.
- No facial animation yet.
- Everything is still using Linear key interpolation.
- At the end of the rough stage, the body animation should almost look as good as done, even though it has linear keys.

### Facial Animation

After pretty much finishing up the body in a Linear state, I start work on the facial animation. I'll typically start by doing just the mouth, and making the lipsync look ok. This is the Facial 1 movie.

Then I'll go back and add some emotion into the mouth, adding more or less smile or frown around what is going on in the lipsync. The keys are all still Linear in this stage as well.

After the mouth is done, I'll go and start the eye motion. Typically I'll animate the brows and lids for expression as needed. All Linear keys, but with no blinks yet. Just keys for

*Contd....*

**Notes**

expression poses to keep things neat and clean in my timeline. That is the Facial 2 movie. I'll also make sure the eyes are looking where they need at this stage.

Eventually I'll be ready to tweak any lipsync and facial issues and to add blinks into the poses. Essentially fixing up the facial animation as needed, all with Linear keys still. This is the Facial 3 movie below.

The aspects of this phase of the animation for me are:

- Everything is still at Linear keys, this helps to not have to worry about accidental overshoot due to interpolation.
- I tend to block in the proper lipsync mouth movement, then add emotion after.
- At the end of this stage both the body and face have been pretty much finished, but with Linear keys.

**Cleanup Animation**

At the end I start my "Cleanup" phase, where I adjust my keys to be smooth. We have a tool at work for Maya, and one I wrote at home in MAX that switches keys to "smooth", but without any extra accidental overshoot.

This allows you to get perfect smooth motion but with no computery accidental peaks or valleys in the interpolation. Normally you'll have to change things to spline/smooth, and then manually tweak tangent handles to get rid of overshoot if it occurs.

I then see how it looks, and tweak things accordingly, maybe offsetting some things, making slight adjustments etc. This is where you can offset rotati hold up when it goes to video on a bigger screen.

This phase has:

- Smooth keys
- Offsets of keys if desired
- This is the final animation.

**Final Animation**

Once I'm done with the animation, I'll take care of any special lighting or rendering issues. I may or may not tweak things a bit more if I start to notice stuff and have time.

**Questions:**

1. What problems did you find in the procedure followed by Michael Comet?
2. What do you think would have been a better process for the animation?

Source: <http://www.comet-cartoons.com/3ddocs/animprocess/>

**8.5 Summary**

- Computer animation or CGI animation is the process used for generating animated images by using computer graphics.
- principles of animation became the generally accepted techniques according to Don Graham who worked with Walt Disney in founding the industry that you see today.
- Using appropriate software and techniques, you can animate visual images in many ways.

- When designing a character for any particular animated medium (2D or 3D), the designer must consider what their design will look like from all angles and from all points of view.
- A model sheet is the blueprint of a character, defining its size, construction, and proportions.
- Before you can work with a frame, you must select it as the current frame. The contents of the current frame appear in the document window.
- When you create an animation, organise its execution into a series of logical steps. First, gather up in your mind all the activities you wish to provide in the animation.
- Computer animation programs typically employ the same logic and procedural concepts as cel animation and use the vocabulary of classic cel animation—terms such as layer, keyframe, and tweening.
- Some file formats are designed specifically to contain animations, so they can be ported among applications and platforms with the proper translators. Those formats include Director (.dir and .dcr), AnimatorPro (.fli and .flc), 3D Studio Max (.max), GIF89a (.gif), and Flash (.fla and .swf). Because file size is a critical factor when downloading animations to play on web pages, file compression is an essential part of preparing animation files for the Web.

## 8.6 Keywords

**Anticipation:** This movement prepares the audience for a major action the character is about to perform, such as, starting to run, jump or change expression.

**Arcs:** All actions, with few exceptions (such as the animation of a mechanical device), follow an arc or slightly circular path.

**Follow through and Overlapping Action:** When the main body of the character stops all other parts continue to catch up to the main mass of the character, such as arms, long hair, clothing, coat tails or a dress, floppy ears or a long tail (these follow the path of action).

**Slow-out and Slow-in:** As action starts, we have more drawings near the starting pose, one or two in the middle, and more drawings near the next pose.

**Squash and Stretch:** This action gives the illusion of weight and volume to a character as it moves.

**Staging:** A pose or action should clearly communicate to the audience the attitude, mood, reaction or idea of the character as it relates to the story and continuity of the story line.

**Straight Ahead and Pose-To-Pose Animation:** Straight ahead animation starts at the first drawing and works drawing to drawing to the end of a scene.

**Tweening:** It is an action that requires calculating the number of frames between keyframes and the path the action takes, and then actually sketching with pencil the series of progressively different outlines.

## 8.7 Review Questions

1. Define Animation with example.
2. Describe principles of animation.
3. What do you understand by the following in context to animation:
  - (a) Squash and Stretch

- Notes
- (b) Pose-to-pose animation
  - (c) Exaggeration
  - 4. Explain animation fundamentals.
  - 5. Discuss animation techniques.
  - 6. Describe animation file formats.

### Answers: Self Assessment

- |                        |                        |
|------------------------|------------------------|
| 1. (a)                 | 2. (c)                 |
| 3. (a)                 | 4. (d)                 |
| 5. (c)                 | 6. (d)                 |
| 7. (a)                 | 8. (b)                 |
| 9. (a)                 | 10. (c)                |
| 11. (b)                | 12. (c)                |
| 13. "2½-D"             | 14. Path               |
| 15. 3-D                | 16. Tweening           |
| 17. Reflective Sensors | 18. Computer Animation |
| 19. False              | 20. True               |

### 8.8 Further Readings



#### Books

Frederick P. Brooks, Jr., Kenan Professor of Computer Science. *The Mythical Man-Month: Essays in Software Engineering*. University of North Carolina at Chapel Hill.

K. Andleigh and K. Thakkar. *Multimedia System Design*. PHI, PTR.

Steve Rimmer (2000). *Advanced Multimedia Programming*. MHI.



#### Online links

[http://books.google.co.in/books?id=1odsKtv46ZQC&lpq=PA193&ots=muU4yj5Ab8&dq=Fundamental %20of %20Animations&pg=PA193#v=onepage&q&f=false](http://books.google.co.in/books?id=1odsKtv46ZQC&lpq=PA193&ots=muU4yj5Ab8&dq=Fundamental%20of%20Animations&pg=PA193#v=onepage&q&f=false)

<http://nora.lis.uiuc.edu:3030/companion/view?docId=blackwell/9781405103213/9781405103213.xml&doc.view=print&chunk.id=ss1-2-10&toc.depth=1&toc.id=0>

[http://users.mct.open.ac.uk/yr258/papers/Rogers\\_Scaife98.pdf](http://users.mct.open.ac.uk/yr258/papers/Rogers_Scaife98.pdf)

<http://www.icheg.org/icheg-game-history/timeline/>

<http://www.ict.griffith.edu.au/teaching/1611ICT/mm1alectures/111/Writing%20For%20Multimedia%20Great%20Moments%20In%20Multimedia%20History.htm>

## Unit 9: Working with Animation

Notes

### CONTENTS

Objectives

Introduction

- 9.1 Video and Digital Movie Tools
  - 9.1.1 Video Editing Software
  - 9.1.2 DVD Authoring Software
  - 9.1.3 Multimedia Player
- 9.2 Multimedia Authoring Tools
  - 9.2.1 Helpful Ways to Get Started
  - 9.2.2 Making Instant Multimedia
  - 9.2.3 Types of Authoring Tools
- 9.3 Components of an Authoring Tool
  - 9.3.1 Choosing an Authoring Software
- 9.4 Summary
- 9.5 Keywords
- 9.6 Review Questions
- 9.7 Further Readings

### Objectives

After studying this unit, you will be able to:

- Describe video and digital movie tools
- Explain various types of multimedia authoring tools
- Understand components of an authoring tool

### Introduction

Animation catches the eye and makes things noticeable. But, like sound, animation quickly becomes trite if it is improperly applied. Unless your project has a backbone of movie-like, animated imagery, use animation carefully (and sparingly) like spice to achieve the greatest impact. Your screens may otherwise become busy and “noisy.”

Multimedia authoring systems typically provide tools to simplify creating animations within that authoring system, and they often have a mechanism for playing the special animation files created by dedicated animation software. Today, the most widely used tool for creating multimedia animations for Macintosh and Windows environments and for the Web is Adobe’s Flash. Flash directly supports several 2½-D features, including z-axis positioning, automatic sizing and perspective adjustment, and kinematics. External libraries can extend Flash’s capabilities: open-source Papervision 3D provides extensive support for true 3-D modelling and animation.

## 9.1 Video and Digital Movie Tools

Carefully planned, well-executed video clips can make a dramatic difference in a multimedia project. A clip of John F. Kennedy proclaiming “Ich bin ein Berliner” in video and sound is more compelling than a scrolling text field containing that same speech. Before deciding whether to add video to your project, however, it is essential to have an understanding of the medium, its limitations, and its costs. This unit provides a foundation to help you understand how video works, the different formats and standards for recording and playing video, and the differences between computer and television video.

Video standards and formats are still being refined as transport, storage, compression, and display technologies take shape in laboratories and in the marketplace and while equipment and post-processing evolves from its analog beginnings to become fully digital, from capture to display. Working with multimedia video today can be like a Mojave Desert camping trip: you may pitch your tent on comfortable high ground and find that overnight the shifting sands have buried both your approach and your investment.



*Did u know?* Of all the multimedia elements, video places the highest performance demand on your computer or device—and its memory and storage.

Consider that a high-quality colour still image on a computer screen could require as much as a megabyte or more of storage memory. Multiply this by 30—the number of times per second that the picture is replaced to provide the appearance of motion—and you would need at least 30 megabytes of storage to play your video for one second, more than 1.8 gigabytes of storage for a minute, and 108 gigabytes or more for an hour. Just moving all this picture data from computer memory to the screen at that rate would challenge the processing capability of a supercomputer. Some of the hottest and most arcane multimedia technologies and research efforts have dealt with compressing digital video image data into manageable streams of information. Compression (and decompression), using special software called a codec, allows a massive amount of imagery to be squeezed into a comparatively small data file, which can still deliver a good viewing experience on the intended viewing platform during playback.

If you control the delivery platform for your multimedia project, you can specify special hardware and software enhancements that will allow you to work with high-definition, full-motion video, and sophisticated audio for high-quality surround sound. Or you can design a project to meet a specific compression standard, such as MPEG2 for Digital Versatile Disc (DVD) playback or MPEG4 for home video. You can install a superfast RAID (Redundant Array of Independent Disks) system that will support high-speed data transfer rates. You can include instructions in your authoring system that will spool video clips into RAM, ready for high-speed playback before they need to play. Having control of the playback platform is always good, but it is seldom available in the real world, so as you develop your video elements, you will need to make many choices and compromises based upon your assessment of the “lowest common denominator” playback platform where your project will be used.



*Notes* You can make movies with a simple video camera. Simply catch the scenes, upload the file created on your computer, and play it. But if you want your digital videos to look less like the work of an amateur, you have got to start using digital video tools.

### 9.1.1 Video Editing Software

Notes

To make movies from video, you may need special hardware to convert an analog video signal to digital data. Macs and PCs with FireWire (IEEE 1394) or USB ports can import digital video directly from digital camcorders. Movie-making tools such as Premiere, Final Cut Pro, VideoShop, and MediaStudio Pro let you edit and assemble video clips captured from camera, tape, other digitized movie segments, animations, scanned images, and from digitized audio or MIDI files. The completed clip, often with added transition and visual effects, can then be played back—either stand-alone or windowed within your project.

Video editing software is application software which handles the post-production video editing of digital video sequences on a computer non-linear editing system (NLE). It has replaced traditional flatbed celluloid film editing tools and analogue video tape-to-tape online editing machines.

NLE software is typically based on a timeline interface paradigm where sections of moving image video recordings, known as clips, are laid out in sequence and played back. The NLE offers a range of tools for trimming, splicing, cutting and arranging clips across the timeline. As digital NLE systems have advanced their toolset, their role has expanded and most consumer and professional NLE systems alike now include a host of features for colour manipulation, titling and visual effects, as well as tools for editing and mixing audio synchronized with the video image sequence.

Once a project is complete, the NLE system can then be used to export to movie in a variety of formats in context which may range from broadcast tape formats to compressed formats for the Internet, DVD and mobile devices.



*Example:* Some of the more popular video editing software are Windows Movie Maker, Apples iMovie, and ArcSoft Inc's ShowBiz DVD.



*Caution* Digital video editing and playback requires an immense amount of free disk space, even when the video files are compressed.



*Task* Develop a movie using digital movie tools to enhance the quality of a movie.

### 9.1.2 DVD Authoring Software

DVD Authoring software is used to create digital video disks which can be played on a DVD player. If you have videos of birthday parties, farewell celebrations, Christmas events, singing, dancing, playing pranks and all your beloved memories that are hiding on your video cameras, mini disks, VHS cassettes, tapes, etc., think of using this software to transfer them to DVDs, which are a good alternative for a low-cost storage device for playing back on a DVD player and sharing with your relatives and friends. Now without needing to edit these videos one by one on your video editing software, you could use DVD authoring software that lets you create and burn videos with interactive menus in various templates, split videos into chapters for easier navigation, add subtitles and audio tracks to these menus, cut scenes from videos and even create photo slideshows with considerable ease. You could also use powerful video editing software to edit and save your videos and then only use DVD authoring software to import them for adding menus, chapters and the like before burning into DVDs.

Notes



*Task* Create a digital video disk that can be played on a DVD player.

### 9.1.3 Multimedia Player

Media player is a term typically used to describe computer software for playing back multimedia files. While many media players can play both audio and video, others focus only on one media type or the other. Such players are known as either audio players or video players and often have a user interface tailored for the specific media type.

Media players often display icons known from physical devices such as tape recorders and CD players.



*Example:* Microsoft Windows comes with Windows Media Player pre-installed. Mac OS X comes pre-loaded with QuickTime Player and iTunes. Linux distributions come pre-loaded with various media players, including SMPlayer, Amarok, Audacious, Banshee, MPlayer, Rhythmbox, Totem, VLC, and xine.

### Self Assessment

Fill in the blanks:

1. Compression (and decompression), using special software called a ....., allows a massive amount of imagery to be squeezed into a comparatively small data file.
2. RAID stands for .....
3. .... software is used to create digital video disks which can be played on a DVD player.
4. .... is a term typically used to describe computer software for playing back multimedia files.

### 9.2 Multimedia Authoring Tools

Multimedia authoring tools provide the important framework you need for organizing and editing the elements of your multimedia project, including graphics, sounds, animations, and video clips. Authoring tools are used for designing interactivity and the user interface, for presenting your project on screen, and for assembling diverse multimedia elements into a single, cohesive product.

Multimedia authoring systems typically provide tools to simplify creating animations within that authoring system, and they often have a mechanism for playing the special animation files created by dedicated animation software. Today, the most widely used tool for creating multimedia animations for Macintosh and Windows environments and for the Web is Adobe's Flash. Flash directly supports several 2½-D features, including z-axis positioning, automatic sizing and perspective adjustment, and kinematics.



*Did u know?* External libraries can extend Flash's capabilities: open-source Papervision3D provides extensive support for true 3-D modelling and animation.



The term authoring results from the fact that the person creating the learning material on the computer is often called the author. Authoring systems are generally menu-driven systems intended to be easy to use by the multimedia developer. They do not require the trainer to get involved with program code. Such systems endeavour to provide a complete, comprehensive authoring.

Authoring software provides an integrated environment for binding together the content and functions of your project, and typically includes everything you need to create, edit, and import specific types of data; assemble raw data into a playback sequence or cue sheet; and provide a structured method or language for responding to user input. With multimedia authoring software, you can make

- Video productions
- Animations
- Games
- Interactive web sites
- Demo disks and guided tours
- Presentations
- Kiosk applications
- Interactive training
- Simulations, prototypes, and technical visualizations

### 9.2.1 Helpful Ways to Get Started

Don't be overwhelmed when starting your multimedia project—there may be a lot of things to think about, but there are also a lot of things that have already been done for you. As the cliché goes, "There's no need to reinvent the wheel!" Consider the following tips for making your production work go smoothly:

- Use templates that people have already created to set up your production. These can include appropriate styles for all sorts of data, font sets, color arrangements, and particular page setups that will save you time.
- Use wizards when they are available—they may save you much time and pre-setup work.
- Use named styles, because if you take the time to create your own it will really slow you down. Unless your client specifically requests a particular style, you will save a great deal of time using something already created, usable, and legal.
- Create tables, which you can build with a few keystrokes in many programs, and it makes the production look credible.
- Help readers find information with tables of contents, running headers and footers, and indexes.
- Improve document appearance with bulleted and numbered lists and symbols.
- Allow for a quick-change replacement using the global change feature.
- Reduce grammatical errors by using the grammar and spell checker provided with the software. Do not rely on that feature, though, to set all things right—you still need to proofread everything.
- Include identifying information in the filename so you can find the file later.

## 9.2.2 Making Instant Multimedia

While this section discusses dedicated multimedia authoring systems, there is no reason to invest in such a package if your current software (or an inexpensive upgrade) can do the job. Indeed, not only can you save money by doing multimedia with tools that are familiar and already at hand, but you also save the time spent on the arduous and sometimes lengthy learning curves involved in mastering many of the dedicated authoring systems.

Common desktop tools have become multimedia-powerful. Some multimedia projects may be so simple that you can cram all the organizing, planning, rendering, and testing stages into a single effort, and make “instant” multimedia.



*Example:* The topic at your weekly sales meeting is sales force performance. You want to display your usual spreadsheet so that the group can see real names and numbers for each member of the team, but then you want to add an animated, multi-coloured 3-D bar graph for visual impact. Preparing for your meeting, you annotate the cell containing the name of the most productive salesperson for the week, using sounds of applause found on the Web or a recording of your CEO saying “Good job!” or a colleague’s “Wait till next week, Pete!” At the appropriate time during the meeting, you click that cell and play the file. And that’s it—you have just made and used instant multimedia.



*Caution* You need special multimedia tools for digitizing your sounds and for creating animations and movies before you can attach these objects to your text, data, or presentation documents.

## 9.2.3 Types of Authoring Tools

Each multimedia project you undertake will have its own underlying structure and purpose and will require different features and functions.

E-learning modules such as those seen on PDAs, MP3 players, and intra-college networks may include web-based teaching materials, multimedia CD-ROMs or web sites, discussion boards, collaborative software, wikis, simulations, games, electric voting systems, blogs, computer-aided assessment, simulations, animation, blogs, learning management software, and email. This is also referred to as distance learning or blended learning, where online learning is mixed with face-to-face learning.

The various multimedia authoring tools can be categorised into three groups, based on the method used for sequencing or organizing multimedia elements and events:

1. **Card- and Page-Based Authoring Tools:** Card-based or page-based tools are authoring systems, wherein the elements are organized as pages of a book or a stack of cards. Thousands of pages or cards may be available in the book or stack. These tools are best used when the bulk of your content consists of elements that can be viewed individually, letting the authoring system link these pages or cards into organized sequences. You can jump, on command, to any page you wish in the structured navigation pattern.

Card-based or page-based tools are authoring systems, wherein the elements are organized as pages of a book or a stack of cards. Thousands of pages or cards may be available in the book or stack. These tools are best used when the bulk of your content consists of elements

that can be viewed individually, letting the authoring system link these pages or cards into organized sequences. You can jump, on command, to any page you wish in the structured navigation pattern.



*Did u know?* It allows you to play sound elements and launch animations and digital video.

Following are some typical messages that might pass along the object hierarchy of the LiveCode and ToolBook authoring systems:

LiveCode Message	ToolBook Message
closeCard	leavePage
closeStack	leaveBook
idle	idle
mouseDown	buttonDown
mouseStillDown	buttonStillDown
mouseUp	buttonUp
newBackground	newBackground
openCard	enterPage
openStack	enterBook

The handler, if placed in the script of the card or page, executes its commands when it receives a “mouseUp” or “buttonUp” event message that occurs at any location on the card or page—not just while the cursor is within the bounds of a button.

Card- and page-based systems typically provide two separate layers on each card: a background layer that can be shared among many cards, and a foreground layer that is specific to a single card.

2. **Icon- and Object-Based Authoring Tools:** Icon- or object-based, event-driven tools are authoring systems, wherein multimedia elements and interaction cues (events) are organized as objects in a structural framework or process. Icon- or object-based, event-driven tools simplify the organization of your project and typically display flow diagrams of activities along branching paths. In complicated navigational structures, this charting is particularly useful during development.

Icon-based, event-driven tools provide a visual programming approach to organizing and presenting multimedia. First you build a structure or flowchart of events, tasks, and decisions, by dragging appropriate icons from a library. These icons can include menu choices, graphic images, sounds, and computations. The flowchart graphically depicts the project’s logic. When the structure is built, you can add your content: text, graphics, animation, sounds, and video movies. Then, to refine your project, you edit your logical structure by rearranging and fine-tuning the icons and their properties.

With icon-based authoring tools, non-technical multimedia authors can build sophisticated applications without scripting.

You can print out your navigation map or flowchart, an annotated project index with or without associated icons, design and presentation windows, and a cross-reference table of variables.

Notes



*Notes* In Authorware from Adobe, by placing icons on a flow line, you can quickly sequence events and activities, including decisions and user interactions. These tools are useful for story-boarding, as you can change sequences, add options, and restructure interactions by simply dragging and dropping icons.

3. **Time-Based Authoring Tools:** Time-based tools are authoring systems, wherein elements and events are organized along a timeline, with resolutions as high as or higher than 1/30 second. Time-based tools are best to use when you have a message with a beginning and an end. Sequentially organized graphic frames are played back at a speed that you can set. Other elements (such as audio events) are triggered at a given time or location in the sequence of events.

The more powerful time-based tools let you program jumps to any location in a sequence, thereby adding navigation and interactive control. Each tool uses its own distinctive approach and user interface for managing events over time. Many use a visual timeline for sequencing the events of a multimedia presentation, often displaying layers of various media elements or events alongside the scale in increments as precise as one second. Others arrange long sequences of graphic frames and add the time component by adjusting each frame's duration of play.

4. **Flash:** Flash is a time-based development environment. Flash, however, is also particularly focused on delivery of rich multimedia content to the Web. With the Flash Player plug-in installed in more than 95 percent of the world's browsers, Flash delivers far more than simple static HTML pages. ActionScript, the proprietary, under-the-hood scripting language of Flash, is based upon the international ECMAScript standard derived from Netscape's original JavaScript.
5. **Director:** Adobe's Director is a powerful and complex multimedia authoring tool with a broad set of features to create multimedia presentations, animations, and interactive multimedia applications. It requires a significant learning curve, but once mastered, it is among the most powerful of multimedia development tools. In Director, you assemble and sequence the elements of your project, called a "movie," using a Cast and a Score. The Cast is a multimedia database containing still images, sound files, text, palettes, QuickDraw shapes, programming scripts, QuickTime movies, Flash movies, and even other Director files. You tie these Cast members together using the Score facility, which is a sequencer for displaying, animating, and playing Cast members, and it is made up of frames that contain Cast members, tempo, a palette, timing, and sound information. Each frame is played back on a stage at a rate specified in the tempo channel. Director utilizes Lingo, a full-featured object-oriented scripting language, to enable interactivity and programmed control.

**Self Assessment**

Fill in the blanks:

5. .... tools provide the important framework you need for organizing and editing the elements of your multimedia project, including graphics, sounds, animations, and video clips.
6. The term authoring results from the fact that the person creating the learning material on the computer is often called the .....

7. .... systems are generally menu-driven systems intended to be easy to use by the multimedia developer.
8. .... tools are authoring systems, wherein the elements are organized as pages of a book or a stack of cards.
9. .... tools are authoring systems, wherein multimedia elements and interaction cues (events) are organized as objects in a structural framework or process.
10. .... tools are authoring systems, wherein elements and events are organized along a timeline, with resolutions as high as or higher than 1/30 second.
11. .... is a time-based development environment.
12. Adobe's ..... is a powerful and complex multimedia authoring tool with a broad set of features to create multimedia presentations, animations, and interactive multimedia applications.

Notes

### 9.3 Components of an Authoring Tool

In multimedia authoring systems, multimedia elements and events are often treated as objects that live in a hierarchical order of parent and child relationships. Messages passed among these objects order them to do things according to the properties or modifiers assigned to them.



*Example:* In this way Teen-child (a teenager object) may be programmed to take out the trash every Friday evening, and does so when they get a message from Dad. Spot, the puppy, may bark and jump up and down when the postman arrives, and is defined by barking and jumping modifiers.

Objects typically take care of themselves. Send them a message and they do their thing without external procedures and programming. Objects are particularly useful for games, which contain many components with many “personalities,” all for simulating real-life situations, events, and their constituent properties. Object-based authoring programs typically provide objects pre-programmed with sensible properties, messages, and functions.



*Example:* A video object will likely have a duration property (how long the video plays) and a source property (the location of the video file) and it will likely accept commands from the system such as “play” and “stop.”

#### 9.3.1 Choosing an Authoring Software

In the best case, you must be prepared to choose the tool that best fits the job; in the worst case, you must know which tools will at least “get the job done.” Authoring tools are constantly being improved by their makers, who add new features and increase performance with upgrade development cycles of six months to a year. It is important that you study the software product reviews in the blogs and computer trade journals, as well as talk with current users of these systems, before deciding on the best ones for your needs. Here’s what to look for:

##### Editing Features

The elements of multimedia—images, animations, text, digital audio and MIDI music, and video clips—need to be created, edited, and converted to standard file formats, using the specialized applications which provide these capabilities. Also, editing tools for these elements,

**Notes**

particularly text and still images, are often included in your authoring system. The more editors your authoring system has, the fewer specialized tools you may need. In many cases, however, the editors that may come with an authoring system will offer only a subset of the substantial features found in dedicated tools. According to Vaughan's Law of Multimedia Minimums, these features may very well be sufficient for what you need to do; on the other hand, if editors you need are missing from your authoring system, or if you require more power, it's best to use one of the specialized, single-purpose tools.

**Organizing Features**

The organization, design, and production process for multimedia involves story-boarding and flowcharting. Some authoring tools provide a visual flowcharting system or overview facility for illustrating your project's structure at a macro level. Storyboards or navigation diagrams can also help organize a project and can help focus the overall project scope for all involved. Because designing the interactivity and navigation flow of your project often requires a great deal of planning and programming effort, your storyboard should describe not just the graphics of each screen, but the interactive elements as well. Features that help organize your material are a plus. Many web-authoring programs such as Dreamweaver include tools that create helpful diagrams and links among the pages of a web site. Planning ahead in an organized fashion may prevent countless moments of indecision, keep the client from changing her mind without periodic sign-offs on the materials included, and, in the long run, save you money.

**Programming Features**

Multimedia authoring systems offer one or more of the following approaches, as explained in the following paragraphs:

- Visual programming with cues, icons, and objects
- Programming with a scripting language
- Programming with traditional languages, such as Basic or C
- Document development tools

Visual programming with icons or objects is perhaps the simplest and easiest authoring process. If you want to play a sound or put a picture into your project, just drag the element's icon into the playlist—or drag it away to delete it.

Authoring tools that offer a very high level language (VHLL) or interpreted scripting environment for navigation control and for enabling user inputs or goal-oriented programming languages—such as Flash, LiveCode, Director, and ToolBook—are more powerful by definition. The more commands and functions provided in the scripting language, the more powerful the authoring system. Once you learn a scripting language, you will be able to learn other scripting languages relatively quickly; the principles are the same, regardless of the command syntax and keywords used.

As with traditional programming tools, look for an authoring package with good debugging facilities, robust text editing, and online syntax reference. Other scripting augmentation facilities are advantageous, as well. In complex projects, you may need to program custom extensions of the scripting language for direct access to the computer's operating system.

A powerful document reference and delivery system is a key component of some projects. Some authoring tools offer direct importing of pre-formatted text, indexing facilities, complex text search mechanisms, and hypertext linkage tools. These authoring systems are useful for

development of CD-ROM information products, online documentation and help systems, and sophisticated multimedia-enhanced publications.

With scripts, you can perform computational tasks; sense and respond to user input; create character, icon, and motion animations; launch other applications; and control external multimedia devices.

### Interactivity Features

Interactivity empowers the end users of your project by letting them control the content and flow of information. Authoring tools should provide one or more levels of interactivity:

- Simple branching, which offers the ability to go to another section of the multimedia production (via an activity such as a keypress, mouse click, or expiration of a timer)
- Conditional branching, which supports a go-to base on the results of IF-THEN decisions or events
- A structured language that supports complex programming logic, such as nested IF-THENS, subroutines, event tracking, and message passing among objects and elements.

### Performance Tuning Features

Accomplishing synchronization is difficult because performance varies widely among the different computers used for multimedia development and delivery. Some authoring tools allow you to lock a production's playback speed to a specified computer platform, but others provide no ability whatsoever to control performance on various systems. In many cases, you will need to use the authoring tool's own scripting language or custom programming facility to specify timing and sequence on systems with different (faster or slower) processors. Be sure your authoring system allows precise timing of events. Complex multimedia projects require exact synchronization of events.



*Example:* The animation of an exploding balloon with its accompanying sound effect.

### Playback Features

As you build your multimedia project, you will be continually assembling elements and testing to see how the assembly looks and performs. Your authoring system should let you build a segment or part of your project and then quickly test it as if the user were actually using it. You should spend a great deal of time going back and forth between building and testing as you refine and smooth the content and timing of the project. You may even want to release the project to others who you trust to run it ragged and show you its weak points.

### Delivery Features

Delivering your project may require building a run-time version of the project using the multimedia authoring software. A run-time version or stand-alone allows your project to play back without requiring the full authoring software and all its tools and editors. Often, the run-time version does not allow users to access or change the content, structure, and programming of the project. If you are going to distribute your project widely, you should distribute it in the run-time version. Make sure your authored project can be easily distributed.

Notes

**Cross-Platform Features**

It is also increasingly important to use tools that make transfer across platforms easy. For many developers, the Macintosh remains the multimedia authoring platform of choice, but 80 per cent of that developer’s target market may be Windows platforms. If you develop on a Macintosh, look for tools that provide a compatible authoring system for Windows or offer a run-time player for the other platform.

**Internet Playability**

Because the Web has become a significant delivery medium for multimedia, authoring systems typically provide a means to convert their output so that it can be delivered within the context of HTML or DHTML, either with special plug-ins or by embedding Java, JavaScript, or other code structures in the HTML document. Test your authoring software for Internet delivery before you build your project. Be sure it performs on the Web as you expect! Test it out for performance stability on as many platforms as you can.

 *Task* Make a presentation explaining the process for choosing the authoring software.

**Self Assessment**

Fill in the blanks:

- 13. .... authoring programs typically provide objects pre-programmed with sensible properties, messages, and functions.
- 14. The organization, design, and production process for multimedia involves ..... and .....
- 15. .... with icons or objects is perhaps the simplest and easiest authoring process.

 *Case Study* **Munich-based Convention “Digitale Cinematographie” Attracts more Exhibitors and Visitors**

**M**unich, Germany, 2008—The digital film and production technology convention “Digitale Cinematographie” organized by Band Pro Munich, Ludwig Camera Rental and MKM Production was taking place for the 6th time in a row. Newest high definition trends, developments and experiences were accompanied by numerous screenings and workshops. A main focus during this unrivalled event throughout Europe was put on 3D stereoscopy. Trade visitors from film and media industry found a very interesting platform for lively discussions.

High definition is about to enter the domain of classic movie-, TV-and commercial production. High definition technology is more and more establishing as production and broadcast standard. Film professionals who will be successful in the future have to look

*Contd....*



## Notes

into HD production. The “Digitale Cinematographie” had more exhibitors and visitors than ever before: 40 exhibitors and 1177 visitors reflect the growing interest in the industry. The so called High Definition Competence Centre, consisting of Band Pro Munich, Ludwig Camera Rental and MKMedia Production, had founded this unique industry platform out of their experience from sales, rental and production supervision. The 2000 qm exhibition space showcased a comprehensive overview on future developments in production and post-production. Hands-on experience is the motor of success of the Digitale Cinematographie knows Gerhard Baier of Band Pro Munich. It is not the exhibition which is in the focus of the convention concept but the whole digital workflow chain. When rental and post production house owner Martin Ludwig had established this show together with Gerhard Baier and Martin Kreitl six years ago, he only thought of one thing: to demonstrate visitors how important it is to think about the result of the production first before starting the digital production process at all.” The Digitale Cinematographie wants to encounter trends by showing actual employments as for example this year’s RED One workflow session” explains Martin Ludwig. For Martin Kreitl the Digitale Cinematographie is even a pathfinder for cutting-edge trends throughout Europe. He is convinced that digital cinematography will offer new and astonishing possibilities for movie- and TV-audience, broadcast stations and cinema operators. He emphatically pointed out that the spread of HDTV and the digital movie theatres underlies no (longer) limitations on digital production technology. He is very positive about the fact that movie theatres could attract more audiences with live coverage from concerts and sports events or stereo 3D-projections.

Many visitors were from the Munich area, which traditionally plays an important role in the worldwide film production industry, as well as from other German film metropolis and neighbouring countries. Manufacturers use the Digitale Cinematographie mainly to present their newest gear and technology aside from the big industry conventions such as NAB and IBC. Especially the Munich-based manufacturers such as ARRI, P+S Technik and Chrosziel use their home field advantage. Also, many of the visitors—who are usually “main artisans” such as production companies and DoPs, etc.—expect to see the latest product generations such as a Sony F35, Sony PMW-EX3 or a RED One first time in Europe. The second day of the show was dedicated to hype stereo 3D-projection and -production. Many discussions with producers and experts on this hot topic comprised on the rules to be followed by shooting 3D and how 3D effects can be best made.

The core of the Digitale Cinematographie, however, is the numerous HD screenings from documentaries to Hollywood blockbusters. The German film award winner film “Kirschblüten-Hanami” by Doris Dörrie and best-director-award-movie at the Cannes film festival „Three Monkeys” (Originaltitel “Üc Maymum”) by Nuri Bilge Ceylan and the numerous 3D trailers were the highlights of the waste screening program.

The workshops met many of the various demands: newest product generations, workflow-scenarios, comparisons of cine and HD objectives, editing software, film and video restoring software, colour grading software, use of studio recorders as well as specialized workshops on 3D-productions. Hands-on camera sets were made up by the famous German movie colleges HFF and BAF and were especially frequented by students. Sony—as main sponsor—was also very happy about the event: “The presentation of the whole digital workflow-spectrum as well as the possibility to get in touch with producers, camera operators, editors and other media professionals make this event even for a global player and broad line manufacturer very valuable,” states Goran Hantschel, Divisional Director Professional Solutions Europe. A constantly increasing number of visitors since the beginning in 2002,

*Contd....*

Notes

more and more digital film productions as well the proceeding establishing of HD/HDTV as production and broadcast standard undermine the importance of the event. The organizers of the Digitale Cinematographie have already committed to keep on pushing this major industry event.

**Questions:**

1. Describe high definition technology.
2. How Munich area plays an important role in worldwide film production industry?

*Source:* <http://www.yumpu.com/en/document/view/7497268/digitale-cinematographie-band-pro-munich-gmbh>

### 9.4 Summary

- Animation catches the eye and makes things noticeable. But, like sound, animation quickly becomes trite if it is improperly applied.
- Video standards and formats are still being refined as transport, storage, compression, and display technologies take shape in laboratories and in the marketplace and while equipment and post-processing evolves from its analog beginnings to become fully digital, from capture to display.
- DVD Authoring software is used to create digital video disks which can be played on a DVD player.
- Media player is a term typically used to describe computer software for playing back multimedia files. While many media players can play both audio and video, others focus only on one media type or the other.
- Multimedia authoring tools provide the important framework you need for organizing and editing the elements of your multimedia project, including graphics, sounds, animations, and video clips.
- Each multimedia project you undertake will have its own underlying structure and purpose and will require different features and functions.
- Card-based or page-based tools are authoring systems, wherein the elements are organized as pages of a book or a stack of cards.
- Icon- or object-based, event-driven tools are authoring systems, wherein multimedia elements and interaction cues (events) are organized as objects in a structural framework or process.
- Time-based tools are authoring systems, wherein elements and events are organized along a timeline, with resolutions as high as or higher than 1/30 second.
- In multimedia authoring systems, multimedia elements and events are often treated as objects that live in a hierarchical order of parent and child relationships.

### 9.5 Keywords

*Authoring:* The term results from the fact that the person creating the learning material on the computer is often called the author.

*Card- and Page-Based Authoring Tools:* These are authoring systems, wherein the elements are organized as pages of a book or a stack of cards.

**Director:** Adobe's Director is a powerful and complex multimedia authoring tool with a broad set of features to create multimedia presentations, animations, and interactive multimedia applications.

**Flash:** It is a time-based development environment.

**Icon- and Object-Based Authoring Tools:** These are authoring systems, wherein multimedia elements and interaction cues (events) are organized as objects in a structural framework or process.

**Media player:** It is a term typically used to describe computer software for playing back multimedia files.

**Multimedia authoring tools:** These provide the important framework you need for organizing and editing the elements of your multimedia project, including graphics, sounds, animations, and video clips.

**Time-Based Authoring Tools:** These are authoring systems, wherein elements and events are organized along a timeline, with resolutions as high as or higher than 1/30 second.

## 9.6 Review Questions

1. Describe video and digital movie tools.
2. Discuss about video editing software.
3. What do you understand by DVD authoring software?
4. Explain the types of multimedia authoring tools.
5. Discuss the components of an authoring tool.
6. Describe the process of choosing an authoring software.

## **Answers: Self Assessment**

- |  |   |
|--|---|
| 1. Codec                               | 2. Redundant Array of Independent Disks |
| 3. DVD Authoring                       | 4. Media player                         |
| 5. Multimedia authoring                | 6. Author                               |
| 7. Authoring                           | 8. Card-based or page-based             |
| 9. Icon- or object-based, event-driven | 10. Time-based                          |
| 11. Flash                              | 12. Director                            |
| 13. Object-based                       | 14. Story-boarding and Flowcharting     |
| 15. Visual programming                 |   |

## 9.7 Further Readings



Books

Frederick P. Brooks, Jr., Kenan Professor of Computer Science, *The Mythical Man-Month: Essays in Software Engineering*, University of North Carolina at Chapel Hill.

Notes

K. Andleigh and K. Thakkar, *Multimedia System Design*, PHI, PTR.

Steve Rimmer (2000), *Advanced Multimedia Programming*, MHI.



Online links

[http://books.google.co.in/books?id=1odsKtv46ZQC&lpg=PA193&ots=muU4yj5Ab8&dq=Fundamental %20of %20Animations&pg=PA193#v=onepage&q&f=false](http://books.google.co.in/books?id=1odsKtv46ZQC&lpg=PA193&ots=muU4yj5Ab8&dq=Fundamental%20of%20Animations&pg=PA193#v=onepage&q&f=false)

<http://nora.lis.uiuc.edu:3030/companion/view?docId=blackwell/9781405103213/9781405103213.xml&doc.view=print&chunk.id=ss1-2-10&toc.depth=1&toc.id=0>

[http://users.mct.open.ac.uk/yr258/papers/Rogers\\_Scaife98.pdf](http://users.mct.open.ac.uk/yr258/papers/Rogers_Scaife98.pdf)

<http://www.icheg.org/icheg-game-history/timeline/>

<http://www.ict.griffith.edu.au/teaching/1611ICT/mm1alectures/l11/Writing%20For%20Multimedia%20Great%20Moments%20In%20Multimedia%20History.htm>

## Unit 10: 3D Modelling and Animation Tools

Notes

### CONTENTS

Objectives

Introduction

10.1 Advanced Animation Tools

10.1.1 Tools of 3D Art

10.1.2 Modelling

10.1.3 Modelling Workflows

10.1.4 Modelling Process

10.2 Image Editing Tools

10.2.1 Making Still Images

10.2.2 Image Editing

10.2.3 Tools Toolbar for Images

10.3 Types of Image Editing Tools

10.3.1 GIMP

10.3.2 Microsoft Digital Image

10.3.3 Microsoft Paint

10.3.4 Adobe Photoshop

10.3.5 Adobe Photoshop Lightroom

10.4 Sound Editing Tools

10.4.1 Editing Digital Recordings

10.5 Types of Sound Editing Tools

10.5.1 Audacity

10.5.2 Power Sound Editor

10.5.3 Audio Recorder

10.5.4 Ardour

10.5.5 Traverso Daw

10.6 Summary

10.7 Keywords

10.8 Review Questions

10.9 Further Readings

Notes

## Objectives

After studying this unit, you will be able to:

- Understand the concept of advanced animation tools
- Discuss the image editing tools and their types
- Explain the sound editing tools and their types

## Introduction

3D animation, which falls into the larger field of 3D computer graphics, is a general term describing an entire industry that utilizes 3D animation computer software and hardware in many types of productions. This unit uses the term 3D animation to refer to a wide range of 3D graphics, including static images or even real solid models printed with a 3D printer called a rapid prototyper. But animation and movement is the primary function of the 3D animation industry.

3D animation is used in three primary industries:

- Entertainment
- Scientific
- Other

Each of these industries uses 3D animation in completely different ways and for different final output, including film, video, visualizations, rapid prototyping, and many others. The term 3D animation is still evolving, and we have not yet seen everything that it will encompass.

A 3D artist is anyone who works in the production stage of 3D animation: modeller, rigger, texturer, animator, visual effects technician, lighter, or renderer. Each of these job titles falls under the umbrella term 3D artist, and so each job can also be referred to more specifically: 3D modeller, 3D texture artist, 3D lighter, 3D animator, and so forth. These jobs are discussed in more detail throughout this book, to give you a good idea of the role of each on a day-to-day basis.

## 10.1 Advanced Animation Tools

Modelling and texturing are two of the primary jobs within the field of 3D animation and are closely tied to one another. Modelling is the act of creating a 3D object. Texturing is applying the colour and surface properties to the model. Every industry that uses 3D animation must start with the creation of a model, which then serves as the foundation for all the other steps in the production pipeline. Texturing is the stage after a model is created, and the application of the texture depends on the geometry type used to create the model.

By looking at each geometry type and workflow individually, you can see the advantages and disadvantages of each and thereby better determine which type to use.

### **10.1.1 Tools of 3D Art**

3D is a diverse subject and comprises of various tools, some of which are explained as follows:

- (i) **3D Modelling:** In 3D computer graphics, 3D modelling is the process of developing a mathematical representation of any three-dimensional surface of object (either inanimate or living) via specialized software. The product is called a 3D model. It can be displayed as

a two-dimensional image through a process called 3D rendering or used in a computer simulation of physical phenomena. The model can also be physically created using 3D printing devices.

- (ii) **Texturing:** Texturing is the process of creating the surfaces and colour attributes of models to make them resemble whatever object they are supposed to represent. A person who textures models is called a texture artist. However, at some studios, the modeller is responsible for texturing models.
- (iii) **Rigging:** Rigging is the logical side of 3D animation, leaving no room for interpretation of what can and cannot be done. All 3D geometry that is going to be animated needs some type of system that provides the animators the control and flexibility needed to move that object in some fashion. This control system is called the rig.
- (iv) **Animation:** Animation, the movement of objects, represents the art and performance side of 3D animation. It deals with all the gray areas of artistic interpretation of motion, performance, and style. Animation occurs when a group of still images that are slightly different from one another are shown in such a way—that is, in sequential order and at a sufficient speed—that our eyes believe something is moving. So animators must be able to make the 3D characters move frame by frame and in a way that the audience believes the inanimate 3D objects on still frames are alive.
- (v) **Rendering:** 3D rendering is the 3D computer graphics process of automatically converting 3D wire frame models into 2D images with 3D photorealistic effects or non-photorealistic rendering on a computer. Rendering is the final process of creating the actual 2D image or animation from the prepared scene. This can be compared to taking a photo or filming the scene after the setup is finished in real life.



*Did u know?* 3D is often extremely time-consuming. It is necessary to budget this precious commodity, otherwise you can run out of time before a project is completed. Do not get caught up in small details that will have little impact on your finished scenes.

### 10.1.2 Modelling

Modelling is an essential part of 3D animation. Everything you see in any 3D animation had to be created (digitized) in one way or another. Typically, a model is either created from scratch or is based on a 3D scan or other form of digitization that is then cleaned up.

Modeller is the job title of an artist who creates or cleans up the geometry of a 3D model. You can think of 3D animation modellers as digital sculptors. Modelling is also typically the starting place for beginners to learn their way around 3D software, because modelling requires you to move around an object, manipulate and correct components of objects, and work with various attributes and properties of the 3D software. However, just because modelling is a starting place for 3D animators to become familiar with the software does not make it easy to master. It takes years of practice to perfect a modelling workflow, create models with efficient and proper resolution, gain an understanding of how physical objects work and are put together, and understand human anatomy before becoming a proficient and professional modeller.

Most people in 3D animation either love or hate modelling, because the technical limitations of the software can make the task feel unnatural to beginning 3D artists. Models created in 3D software such as Autodesk Maya, 3ds Max, and Softimage require artists to move individual components (in some instances, one at a time), which is not a natural modelling experience. New software, including Pixologic's ZBrush and Autodesk Mudbox, has incorporated the idea of sculpture so that artists can work as if pushing and pulling clay. This change has improved modelling workflows and enhanced the level of final detail in the models.

**Notes**

A modeller can use three geometry types to create models: polygons, non-uniform rational B-splines (NURBS), and subdivision surfaces. These geometry types are the mathematical representations of a 3D form. Each has its advantages and disadvantages and component-level differences. You should be familiar with all three types because the one you use will be dictated by each particular project and by the production pipeline used by the studio. In addition, there are many techniques used to create a 3D model. You can model from reference images, use 3D scanning, perform digital sculpting, or start with basic geometric shapes such as spheres, cubes, cylinders, cones, and flat planes. This section presents a closer look at the geometry types and the basic techniques used today, to give you a better idea of what is out there.



*Notes* In the beginning, it can be difficult to know where to start. Over time, the process will become easier, but if you are constantly switching between various forms, the process will change and it may feel like you are starting over.

**10.1.3 Modelling Workflows**

Modelling workflows can be different depending on the type of model you are using, the project's final outcome, and the studio you work for. In this section, you'll look at a few basic types of workflows: from-scratch modelling, primitive modelling, box modelling, Boolean modelling, laser scanning, and digital sculpting. Each workflow provides the same result but takes you along a different path to get there. Modellers typically start with concept art or real-world images of the objects they are to create as references and produce a 3D model in whatever software they are using. All of these workflows do have a high-level structure in common: you start with a low-resolution topology and then add topology as needed for details.

**10.1.4 Modelling Process**

There are three popular ways to represent a model:

- (i) **Polygonal modelling:** Points in 3D space, called vertices, are connected by line segments to form a polygonal mesh. The vast majority of 3D models today are built as textured polygonal models, because they are flexible and because computers can render them so quickly. However, polygons are planar and can only approximate curved surfaces using many polygons.
- (ii) **Curve modelling:** Surfaces are defined by curves, which are influenced by weighted control points. The curve follows (but does not necessarily interpolate) the points. Increasing the weight for a point will pull the curve closer to that point. Curve types include non-uniform rational B-spline (NURBS), splines, patches and geometric primitives.
- (iii) **Digital sculpting:** Still a fairly new method of modelling, 3D sculpting has become very popular in the few years it has been around. There are currently 3 types of digital sculpting: Displacement, which is the most widely used among applications at this moment, volumetric and dynamic tessellation. Displacement uses a dense model (often generated by Subdivision surfaces of a polygon control mesh) and stores new locations for the vertex positions through use of a 32-bit image map that stores the adjusted locations. Volumetric which is based loosely on Voxels has similar capabilities as displacement but does not suffer from polygon stretching when there are not enough polygons in a region to achieve a deformation. Dynamic tessellation is similar to Voxel but divides the surface using triangulation to maintain a smooth surface and allow finer details. These methods allow for very artistic exploration as the model will have a new topology created over it once



the models form and possibly details have been sculpted. The new mesh will usually have the original high resolution mesh information transferred into displacement data or normal map data if for a game engine.

Notes



*Notes* The modelling stage consists of shaping individual objects that are later used in the scene. There are a number of modelling techniques, including:

- constructive solid geometry
- implicit surfaces
- subdivision surfaces

Modelling can be performed by means of a dedicated program (e.g., Cinema 4D, •Z, Maya, 3DS Max, Blender, Lightwave, Modo, solidThinking) or an application component (Shaper, Lofter in 3DS Max) or some scene description language (as in POV-Ray). In some cases, there is no strict distinction between these phases; in such cases modelling is just part of the scene creation process.



*Example:* There is no strict distinction between the above-mentioned phases with Caligari trueSpace and Realsoft 3D).

Complex materials such as blowing sand, clouds, and liquid sprays are modelled with particle systems, and are a mass of 3D coordinates which have either points, polygons, texture splats, or sprites assigned to them.



*Task* Find out the qualities that a 3D artist must have.

## Self Assessment

Fill in the blanks:

1. .... is the process of developing a mathematical representation of any three-dimensional surface of object (either inanimate or living) via specialized software.
2. .... is the logical side of 3D animation, leaving no room for interpretation of what can and cannot be done.
3. .... is the process of creating the surfaces and colour attributes of models to make them resemble whatever object they are supposed to represent.
4. ...., the movement of objects, represents the art and performance side of 3D animation.
5. .... is the 3D computer graphics process of automatically converting 3D wire frame models into 2D images with 3D photorealistic effects or non-photorealistic rendering on a computer.
6. .... can be different depending on the type of model you are using, the project's final outcome, and the studio you work for.
7. Points in 3D space, called ....., are connected by line segments to form a polygonal mesh.

## **10.2 Image Editing Tools**

Most authoring systems provide the tools with which you can create the graphic objects of multimedia (text, interactive buttons, vector-drawn objects, and bitmaps) directly on your screen. If one of these tools is not included, the authoring system usually offers a mechanism for importing the object you need from another application. When you are working with animated objects or motion video, most authoring systems include a feature for activating these elements, such as a programming language or special functions for embedding them. Likely, too, your tools will offer a library of special effects—including zooms, wipes, and dissolves. Many multimedia designers do not limit their toolkits to the features of a single authoring platform, but employ a variety of applications and tools to accomplish many specialized tasks.

### **10.2.1 Making Still Images**

Still images may be small or large, or even full screen. They may be coloured, placed at random on the screen, evenly geometric, or oddly shaped. Still images may be a single tree on a wintry hillside; stacked boxes of text against a gray, tartan, or Italian marble background; an engineering drawing; a snapshot of your department manager’s new BMW. Whatever their form, still images are generated by the computer in two ways: as bitmaps (or paint graphics) and as vector-drawn (or just plain “drawn”) graphics. Bitmaps may also be called “raster” images. Likewise, bitmap editors are sometimes called “painting” programs. And vector editors are sometimes called “drawing” programs.

Bitmaps are used for photo-realistic images and for complex drawings requiring fine detail. Vector-drawn objects are used for lines, boxes, circles, polygons, and other graphic shapes that can be mathematically expressed in angles, coordinates, and distances. A drawn object can be filled with colour and patterns, and you can select it as a single object. The appearance of both types of images depends on the display resolution and capabilities of your computer’s graphics hardware and monitor. Both types of images are stored in various file formats and can be translated from one application to another or from one computer platform to another. Typically, image files are compressed to save memory and disk space; many bitmap image file formats already use compression within the file itself.



*Example: GIF, JPEG, and PNG.*

Still images may be the most important element of your multimedia project, or web site. If you are designing multimedia by yourself, put yourself in the role of graphic artist and layout designer. Take the time necessary to discover all the tricks you can learn about your drawing software. Competent, computer-literate skills in graphic art and design are vital to the success of your project. Remember—more than anything else, the user’s judgment of your work will be heavily influenced by the work’s visual impact.

### **10.2.2 Image Editing**

Image editing is the changing of pictures. These pictures can be digital photographs, illustrations, or prints (photographs on film). Some types of editing, such as airbrushing, are done by hand and others are done using photo editing programs like Photoshop and Microsoft Paint. Photo editing is done for many reasons. Many photos of models are edited to remove blemishes and make the model “sexier”. This is usually called retouching, airbrushing or Photoshopping, even if Photoshop is not used to edit the photo. Other reasons to edit a photo include fixing errors (red eye, contrast, brightness, etc.), practical jokes, and tricking people. Photo editing is also used to make completely new images. Photo editing is sometimes called photo manipulation, usually when it is used to trick people.



*Caution* Editing or manipulation of photos or images is done to make corrections or put effects in a photo and is usually called photoshopping, even if Photoshop software is not used to edit the photo.

Image editing in Manifold uses several controls at once to achieve exactly the desired effect. To edit images we can choose:

- **Image menu commands:** These commands perform global changes on the image or the selected area, such as changing hue or contrast. See the Image Menu topic.
- **Transform toolbar commands:** These are simple commands or one-line versions of Image menu commands that change the entire image or just the selected area. See the Transform Toolbar-Images topic.
- **Editing tools:** These are found on the Tools toolbar for image and provide a variety of free hand and assisted editing capabilities.

When we paint into an image, we choose a tool and then set any options for that tool.

- Tools are selected from editing toolbars.
- The specific action of tools is set in the Format Toolbar or in the Tool Properties pane.

The Tools Properties pane should be kept open when editing images so that parameters can be changed as desired.



*Notes* To Edit an Image:

1. Choose a tool.
2. Adjust tool properties (such as colour to be used) in the Tool Properties pane.
3. Use the tool in the image.

### 10.2.3 Tools Toolbar for Images



The Tools toolbar for images hosts the image editing tools. Image editing tools are for the most part analogous to drawing editing tools. There are a few modifications specific to the pixel nature of images.

 **Paint Areas** - A mode button: the selected tool will create filled regions of pixels.

 **Paint Lines** - A mode button: the selected tool will create lines.

 **Paint Points** - A mode button: the selected tool will create points where the mouse cursor changes direction on clicks.

 **Paint Area** - Paint pixels within the region clicked. Creates lines or points if shape modes so specify.

Notes

 **Paint Freeform** - Paint pixels within region about which the mouse is clicked and dragged.

 **Paint Line** - Paint a line defined by straight-line segments between clicks.

 **Paint Box** - Paint a rectangular box using a mouse click and a drag.

 **Paint Box on Centre** - Paint a rectangular box centred on initial mouse click.

 **Paint Circle** - Paint a circle using a mouse click and a drag.

 **Paint Circle on Centre** - Paint a circle centred on initial mouse click.

 **Paint Ellipse** - Paint an ellipse using a mouse click and a drag.

 **Paint Ellipse on Centre** - Paint an ellipse centred on initial mouse click.

 **Brush** - Paint a dot with one click or a continuous line with a click and a drag. Paints unsmoothed free-forms even if smoothing is turned on. Very useful for single pixel editing (click on a pixel to colour it) at high zooms.

 **Paint Bucket** - Click to fill a contiguous region of similarly coloured pixels with foreground colour. Fills to a given tolerance value of colour.

SHIFT click to pour into the given colour in all regions of the image within the given tolerance, even if not contiguous. Use this as a “replace colour” operation.

CTRL click to replace colours within the threshold while retaining the same intensity.

ALT click to paint colour without regard to threshold. Used to fill the entire selection or the entire image (enabled if a snap mode is not set).

CTRL and SHIFT or CTRL and ALT may be combined.

 **Gradient** - Click, drag and release to create a colour gradient from foreground colour to background colour between the click point and ending at the release point.

 **Pick Colour** - Click to pick the colour at that location as the foreground colour.

Shift click to pick the colour at that location as the background colour.



*Task* Make a chart of the tools of image editing.

**Self Assessment**

Fill in the blanks:

8. Bitmaps may also be called .....
9. Bitmap editors are sometimes called .....
10. Vector editors are sometimes called .....
11. .... are used for lines, boxes, circles, polygons, and other graphic shapes that can be mathematically expressed in angles, coordinates, and distances.

12. Many photos of models are edited to remove blemishes and make the model sexier. This is usually called ....., or .....
13. Photo editing is sometimes called ....., usually when it is used to trick people.

Notes

### 10.3 Types of Image Editing Tools

Following are some of the popular image editing tools:

#### 10.3.1 GIMP

GIMP (GNU Image Manipulation Program) is an image retouching and editing tool and is released under the GPLv3 license as free and open-source software. There are versions tailored for most operating systems including Microsoft Windows, OS X and Linux.

GIMP has tools used for image retouching and editing, free-form drawing, resizing, cropping, photo-montages, converting between different image formats, and more specialised tasks. Animated images such as GIF and MPEG files can be created using an animation plugin.

The developers and maintainers of GIMP strive to create a high-end free software graphics application for the editing and creation of original images, photos, icons, graphical elements of web pages and art for user interface elements.

Figure 10.1: Editing an Image in GIMP

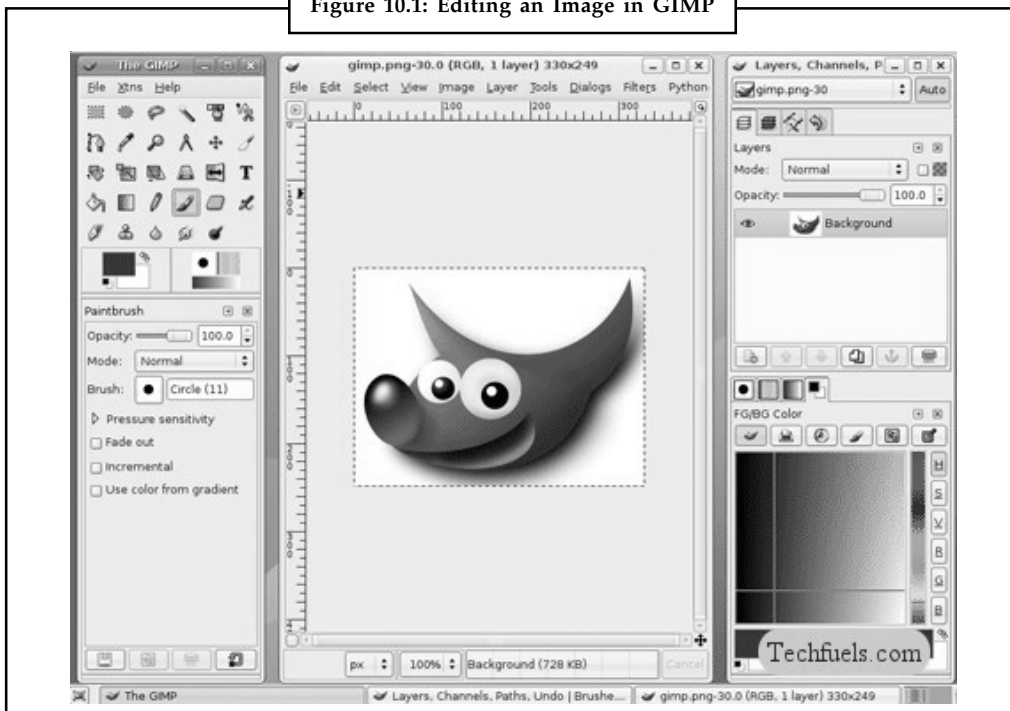

Source: <http://www.techfuels.com/everything-else/14257-gnu-image-manipulation-program.html>

#### 10.3.2 Microsoft Digital Image

Microsoft Digital Image was a digital image editing program created by Microsoft. It was a successor to Microsoft Picture It.

**Notes**

Microsoft Digital Image came in three different editions: Digital Image Standard, which offered tools for editing images, Digital Image Suite, which added Digital Image Library for organizing images and Digital Image Suite Plus, which included tools from Digital Image Suite and the video editing tools of Pinnacle Studio. Digital Image had support for Adobe Photoshop plugins. Later versions also included Photo Story 3.1.

The latest version of this product was Digital Image 2006. This version had native support for Raw camera formats from Canon (.CRW) and Nikon (.NEF) On 19 September 2006, Microsoft released an “anniversary edition” which offered Windows Vista compatibility, removed raw support, added support for Extensible Metadata Platform (XMP) metadata.

The software product was generally well received and praised for its ease of use.



*Notes* On 15 June 2007, Microsoft announced that the Microsoft Digital Image suite would be discontinued because most of the feature set in the Digital Image suite of applications had been integrated into newer Microsoft titles and services, including Windows Photo Gallery (included with Windows Vista) and Windows Live Photo Gallery.

### 10.3.3 Microsoft Paint

Paint (formerly Paintbrush for Windows) is a simple graphics painting program that has been included with all versions of Microsoft Windows. It is often referred to as MS Paint or Microsoft Paint. The program opens and saves files as Windows bitmap (24-bit, 256 colour, 16 colour, and monochrome, all with the .bmp extension), JPEG, GIF (without animation or transparency, although the Windows 98 version, a Windows 95 upgrade, and the Windows NT4 version did support the latter), PNG (without alpha channel), and TIFF (without multiple page support). The program can be in colour mode or two-colour black-and-white, but there is no grayscale mode. For its simplicity, it rapidly became one of the most used applications in the early versions of Windows—introducing many to painting on a computer for the first time—and still has strong associations with the immediate usability of the old Windows workspace.

Recent versions of Paint allow the user to pick up to three colours at a time: the primary colour (left mouse click), secondary colour (right mouse click), and tertiary colour (control key + any mouse click).

The program comes with the following options in its Tool Box (from left to right in image):

- Free-Form Select
- Select
- Eraser/Colour Eraser
- Fill With Colour
- Pick Colour
- Magnifier
- Pencil
- Brush
- Airbrush
- Text
- Line

- Curve
- Rectangle
- Polygon
- Ellipse
- Rounded Rectangle

### 10.3.4 Adobe Photoshop

Photoshop is a program that is so rich, complex, and powerful, people literally spend most of the waking hours of their life using it, and are still always learning new tricks and techniques! Thankfully, however, the learning curve for Photoshop is not steep, and users can create very appealing products with a short introduction to the concepts and tools of Photoshop.

### 10.3.5 Adobe Photoshop Lightroom

Through a series of modules, Lightroom helps photographers manage, develop, and present their photos. Adobe Photoshop Lightroom was developed to meet the needs of professional and serious amateur photographers, and Adobe has done very well in this regard. While Lightroom can offer a lot of benefits for more casual shooters, most of them would probably be better off sticking to a program like Photoshop Elements, or other “family photo” organizing software.

Some of the features of Adobe Lightroom are:

- Lightroom guides the photography workflow through a series of modules: Library, Develop, Map, Book, Slideshow, Print, and Web.
- The Library module is where photos are organized and managed via keywords, flags, collections, metadata, and search features.
- Photos can be reviewed in a number of layouts such as grid, loupe, survey, and compare. Flags, ratings, and labels help with sorting.
- The Develop module provides myriad ways of adjusting exposure, tone, color, lighting, vignettes, and more.
- The Map module allows you to add location information to photos (geo-tagging) and find or sort images by location.
- The Book module lets you design photo books with a variety of templates and upload them for printing.
- The Slideshow module helps you present your photos in a slick, professional presentation that will impress your clients.
- Slideshows can be exported as video files (including HD video), a series of slides in JPEG format, or as a PDF slideshow.
- The Print module provides complete flexibility in creating contact sheets and picture package layouts.
- Applies intelligent sharpening according to the output type and media selected, taking the guesswork out of sharpening.
- The Web module offers a variety of customizable templates for eye-catching Web galleries which can be uploaded directly to a Web site via FTP or exported as a package for a Web developer to post.

Notes

- Lightroom provides Publish Services for sending photos to Flickr, Facebook, SmugMug, and mobile devices. New Publish services can be added through plugins.



*Did u know?* Camera or computer image editing programs often offer basic automatic image enhancement features that correct colour hue and brightness imbalances as well as other image editing features, such as red eye removal, sharpness adjustments, zoom features and automatic cropping.

### Self Assessment

Fill in the blanks:

14. Microsoft Digital Image was a digital image editing program created by Microsoft. It was a successor to .....
15. .... offered tools for editing images.
16. .... added Digital Image Library for organizing images.
17. .... included tools from Digital Image Suite and the video editing tools of Pinnacle Studio. Digital Image had support for Adobe Photoshop plugins.
18. Paint was formerly known as ..... for Windows.

## 10.4 Sound Editing Tools

Digital audio is created when you represent the characteristics of a sound wave using numbers—a process referred to as digitising. You can digitise sound from a microphone, a synthesizer, existing recordings, live radio and television broadcasts, and popular CD and DVDs. In fact, you can digitise sounds from any natural or pre-recorded source. Digitised sound is sampled sound. Every *n*th fraction of a second, a sample of sound is taken and stored as digital information in bits and bytes. The quality of this digital recording depends upon how often the samples are taken (sampling rate or frequency, measured in kilohertz, or thousands of samples per second) and how many numbers are used to represent the value of each sample (bit depth, sample size, resolution, or dynamic range). The more often you take a sample and the more data you store about that sample, the finer the resolution and quality of the captured sound when it is played back. Since the quality of your audio is based on the quality of your recording and not the device on which your end user will play the audio, digital audio is said to be device independent.

### 10.4.1 Editing Digital Recordings

Once a recording has been made, it will almost certainly need to be edited. Audacity is a free open-source sound editing application for Windows, Macintosh, and Linux. With such a tool you can create sound tracks and digital mixes. The basic sound editing operations that most multimedia producers need are described in the paragraphs that follow.

**Trimming:** Removing “dead air” or blank space from the front of a recording and any unnecessary extra time off the end is your first sound editing task. Trimming even a few seconds here and there might make a big difference in your file size. Trimming is typically accomplished by dragging the mouse cursor over a graphic representation of your recording and choosing a menu command such as Cut, Clear, Erase, or Silence.

**Splicing and Assembly:** Using the same tools mentioned for trimming, you will probably want to remove the extraneous noises that inevitably creep into a recording. Even the most controlled



studio voice-overs require touch-up. Also, you may need to assemble longer recordings by cutting and pasting together many shorter ones. In the old days, this was done by splicing and assembling actual pieces of magnetic tape.

**Volume Adjustments:** If you are trying to assemble ten different recordings into a single sound track, there is little chance that all the segments will have the same volume. To provide a consistent volume level, select all the data in the file, and raise or lower the overall volume by a certain amount. Don't increase the volume too much, or you may distort the file. It is best to use a sound editor to normalize the assembled audio file to a particular level, say 80 per cent to 90 per cent of maximum (without clipping), or about -16 dB. Without normalizing to this rule-of-thumb level, your final sound track might play too softly or too loudly. Even pros can leave out this important step. Sometimes an audio CD just doesn't seem to have the same loudness as the last one you played, or it is too loud and you can hear clipping.

**Format Conversion:** In some cases, your digital audio editing software might read a format different from that read by your presentation or authoring program. Most sound editing software will save files in your choice of many formats, most of which can be read and imported by multimedia authoring systems. Data may be lost when converting formats. If, for example, you have a Digital Rights Management (DRM)-protected M4P file downloaded from the iTunes store and burn that file to an Audio CD track, the DRM data will be lost because the Audio CD format does not provide for DRM data. The now-unprotected tune on the CD can then be ripped into a playable MP3 format.

**Re-sampling or Downsampling:** If you have recorded and edited your sounds at 16-bit sampling rates but are using lower rates and resolutions in your project, you must re-sample or downsample the file. Your software will examine the existing digital recording and work through it to reduce the number of samples. This process may save considerable disk space.



**Caution** Once a sound effect is processed and mixed onto a track, it cannot be further edited, so always save the original so that you can tweak it again if you are not happy.

**Fade-ins and Fade-outs:** Most programs offer enveloping capability, useful for long sections that you wish to fade in or fade out gradually. This enveloping helps to smooth out the very beginning and the very end of a sound file.

**Equalisation:** Some programs offer digital equalization (EQ) capabilities that allow you to modify a recording's frequency content so that it sounds brighter (more high frequencies) or darker (low, ominous rumbles).

**Time Stretching:** Advanced programs let you alter the length (in time) of a sound file without changing its pitch. This feature can be very useful, but watch out: most time-stretching algorithms will severely degrade the audio quality of the file if the length is altered more than a few per cent in either direction.

**Digital Signal Processing (DSP):** Some programs allow you to process the signal with reverberation, multi-tap delay, chorus, flange, and other special effects using digital signal processing (DSP) routines.

Being able to process a sound source with effects can greatly add to a project. To create an environment by placing the sound inside a room, a hall, or even a cathedral can bring depth and dimension to a project. But a little can go a long way—do not overdo the sound effects!

**Reversing Sounds:** Another simple manipulation is to reverse all or a portion of a digital audio recording. Sounds, particularly spoken dialog, can produce a surreal, other worldly effect when played backward.

**Notes**

**Multiple Tracks:** Being able to edit and combine multiple tracks (for sound effects, voice-overs, music, etc.) and then merge the tracks and export them in a “final mix” to a single audio file is important.



*Task* Visit three web sites that use sound (you may need to find Flash-based web sites). Where, when, and how is sound used?

**Self Assessment**

Fill in the blanks:

- 19. Digital Audio is created when you represent the characteristics of a sound wave using numbers—a process referred to as .....
- 20. .... implies removing dead air or blank space from the front of a recording and any unnecessary extra time off the end is your first sound editing task.
- 21. .... implies using the same tools mentioned for trimming, you will probably want to remove the extraneous noises that inevitably creep into a recording.

**10.5 Types of Sound Editing Tools**

Following are some of the important sound editing tools:

**10.5.1 Audacity**

Audacity is a free open source digital audio editor and recording computer software application, available for Windows, Mac OS X, Linux and other operating systems. In addition to recording audio from multiple sources, Audacity can be used for post-processing of all types of audio, including podcasts by adding effects such as normalization, trimming, and fading in and out.



*Caution* Audacity does not directly support WMA, AAC, or most other proprietary or restricted file formats. To import or export AC3, AMR(NB), M4A, WMA and other proprietary formats, requires the optional FFmpeg library.

**10.5.2 Power Sound Editor**

Power Sound Editor helps you record new audio file from a microphone, sound card or other input devices (you can record audio from DVD/VCD/CD Player, MP3 Player, RealPlayer, Windows Media Player, Web Page, Internet Conversation, Internet News, Internet Radio Station and more). This Power Sound Editor allows you to visually edit an audio file (Delete, Cut, Copy, Paste, Paste From File, Mix, Mix From File) and apply different effects (Amplify, Delay, Equalizer, Fade, Flanger, Invert, Normalize, Reverse, MultiTapDelay, Silence, Stretch, Vibrato, Echo, Chorus).



*Notes* Power Sound Editor Free supports a wide range of audio formats, such as MPEG (MP3, MP2), WAV, Windows Media Audio, Ogg Vorbis, Audio Tracks and Dialogic VOX.

### 10.5.3 Audio Recorder

Notes

This helps you record and edit audio files visually; record audio from a microphone or any other available input device; apply various effects; burn audio CDs from MP3, WMA, WAV, and OGG; all in one program, simple and intuitive.

### 10.5.4 Ardour

Ardour is a hard disk recorder and digital audio workstation application. It runs on Linux, OS X and FreeBSD. Ardour's intention is to provide digital audio workstation software suitable for professional use. The basic features of ardour are recording, mixing, editing and mastering.



*Notes* Ardour attempts to adhere to industry standards, such as SMPTE/MTC, Broadcast WAVE, MIDI Machine Control and XML.

### 10.5.5 Traverso Daw

It is an audio recording and editing program which is very well suited to record a single voice, a band, an ensemble, a whole orchestra or any other source of music

### Self Assessment

Fill in the blanks:

22. .... is a free open source digital audio editor and recording computer software application, available for Windows, Mac OS X, Linux and other operating systems.
23. .... helps you record and edit audio files visually; record audio from a microphone or any other available input device; apply various effects; burn audio CDs from MP3, WMA, WAV, and OGG; all in one program, simple and intuitive.



*Case Study*

### How 3D Animation helped save the Smartcode Deadbolt

#### Introduction

Black & Decker Corporation is an American manufacturer of power tools and accessories, hardware and home improvement products, and technology based fastening systems.

#### Challenge

When Black & Decker released its SmartCode Deadbolt, the company's product managers and marketing teams had high hopes for the new lock's success. As anticipated, following a successful launch and extensive promotion, sales began to grow.

However, within weeks, Black & Decker's retail partners began reporting a high rate of product returns and consumer complaints. The reason? Customers were simply unable to install the product successfully - even with the printed brochure included in every SmartCode package.

*Contd....*

Notes

The Black & Decker team realized that, in order to keep their new technology on the shelves, they needed to develop a new instructional guide that explained the installation process more effectively to the buyer. And time was of the essence, as they had only 30 days to turn around the return rates.

**Solution**

Screenshot from 3D instructional animation showing how to align and connect electrical components of the Smartcode Deadbolt

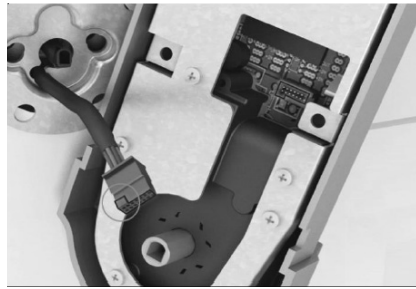

The Black & Decker creative team began by designing new print inserts that were more reader-friendly than the previous brochures. But they didn't stop there. They also decided to produce detailed instructional videos that walked the customer through every phase of the installation process.

Finally, they would combine the best of both solutions by printing QR codes next to key steps described in the new instructions. Each QR code would give the customer access to a short instructional video which helped clarify that particular step in the procedure.

3D instruction animation showing both the interior and exterior assembly while drawing attention to the deadbolt



When the team began production, they quickly determined that traditional video would fail to capture the level of detail needed to clarify the instructions. As a result, they began to explore the use of 3D animation. After careful research, the Black & Decker team decided to partner with MediaLab 3D Solutions, a company specializing in high-quality 3D product imaging and animation.

The team quickly came to appreciate, not only the high quality of the imaging, but also the flexibility offered by the medium. According to Jeff Harris, Black & Decker Creative Manager, – You can do so much more with 3D animation than you can with video.

–With animation, you can switch colors, add highlights, show actions in slow motion, flip products around, show cutaways, and include details you just cannot capture with a video or film camera.

Contd....

The MediaLab team worked closely with their Black & Decker associates to understand the SmartCode Deadbolt from the inside out. Then, they created a series of narrated instructional animations that successfully clarified and simplified every step of the installation process.

## Results

### *Positive Customer Feedback*

Response to the product animations has been dramatic. Harris notes, "Even following the first round of the SmartCode animations, people were blown away. They'd say, 'You've made something that appeared so complex, suddenly seem so simple to install.'"

### *Enhanced Branding*

The instructional animations not only succeeded in helping the company keep its innovative product on the shelves, they also boosted Black & Decker's brand image. While the 3D animations were helpful and effective – their realism, high quality and beauty also left a positive impression in consumers' minds regarding Black & Decker.

### *International Reach*

After witnessing the success of the SmartCode instructional animations in the United States, Black & Decker's international group requested that they be re-purposed, translated and distributed to markets around the globe. The consistent high quality of 3D animation makes it much easier than traditional video to revise for use across multiple channels.

### *Internal Momentum*

Even as the SmartCode's innovative approach to instructions helped boost consumer confidence, it also generated renewed enthusiasm among the Black & Decker product teams.

"They're now rallying around these brands," says Harris. "There's a lot of excitement among the product developers. Now, technology like the SmartCode lock is getting extra attention because of the beautiful 3D animations. This has been a big motivator and has instilled great confidence in our teams."

Harris adds that the recent multimedia approach to instructions has also raised the bar for future content, by encouraging greater collaboration among departments. Now, in addition to working with the engineering and technical publication teams to develop instructional guides, Black & Decker product managers recognize that partnering with their design team and animation experts like MediaLab can take instructional content to an entirely new level.

## Next Steps

### *Expand Scope of Instructional Animations*

The success of the SmartCode 3D animations has opened new opportunities for improving Black & Decker's instruction guides for its customers. Harris notes, "Anything I can imagine can be done. I'm no longer limited by the constraints of traditional video. 3D animation is such an asset to have in my 'back pocket' as a capability. It's empowering."

So empowering, in fact, that at a recent product development meeting, the company decided to partner once again with MediaLab – this time to create installation animations for its entire line of door locks (roughly 150–180 SKUs).

Contd....

Notes

Harris also sees the potential of interactive 3D animation for helping customers learn about the company's advanced Home Connect Technology offerings – which include networked security and comfort features that reach beyond door locks. Harris is excited about these upcoming projects because "MediaLab is great at helping us articulate complex product features that are hard to capture with traditional video."

***Strengthen Retail Partnerships***

Product animations were recently included in Black & Decker's line review meetings with their retail partners. "The instructional animations really hit a home run with the retail buyers," explains Harris. "This will certainly impact our forecasts for next year."

For the company's Worldwide Product Planning Meeting, Harris' team partnered with MediaLab to create demonstrative animations for products still in development. "We've blown the doors off these meetings. Attendees were very impressed. This exposure ended up positively impacting our business in quite a few different areas."

***Sales Force Support***

Black & Decker's commercial technologies have typically required physical product demonstrations at presentations with prospective buyers. In the past, with only a handful of demo units available, sales managers often had to delay a sales call or wait until a unit became available.

"Armed with high quality 3D product animations, the sales team will become more efficient, since they'll no longer have to set up and demo a physical unit for every prospect," explains Harris.

**Questions:**

1. What problem did you find in the solution Black & Drecker gave?
2. Suggest a better solution if you would have been in their position.

Source: <http://www.medialab3dsolutions.com/3d-animation-saved-smartcode-deadbolt>

## **10.6 Summary**

- 3D animation, which falls into the larger field of 3D computer graphics, is a general term describing an entire industry that utilizes 3D animation computer software and hardware in many types of productions.
- Modelling and texturing are two of the primary jobs within the field of 3D animation and are closely tied to one another.
- Texturing is the process of creating the surfaces and colour attributes of models to make them resemble whatever object they are supposed to represent.
- Modelling is an essential part of 3D animation. Everything you see in any 3D animation had to be created (digitized) in one way or another.
- Modelling workflows can be different depending on the type of model you are using, the project's final outcome, and the studio you work for.
- Microsoft Digital Image was a digital image editing program created by Microsoft. It was a successor to Microsoft Picture It.
- Paint (formerly Paintbrush for Windows) is a simple graphics painting program that has been included with all versions of Microsoft Windows.

## 10.7 Keywords

Notes

**3D modelling:** It is the process of developing a mathematical representation of any three-dimensional surface of object (either inanimate or living) via specialized software.

**Animation:** It is the movement of objects, represents the art and performance side of 3D animation.

**Editing tools:** These are found on the Tools toolbar for image and provide a variety of free hand and assisted editing capabilities.

**GIMP:** GIMP (GNU Image Manipulation Program) is an image retouching and editing tool.

**Modelling:** It is the act of creating a 3D object.

**Rendering:** It is the 3D computer graphics process of automatically converting 3D wire frame models into 2D images with 3D photorealistic effects or non-photorealistic rendering on a computer.

**Rigging:** It is the logical side of 3D animation, leaving no room for interpretation of what can and cannot be done.

**Texturing:** It is applying the colour and surface properties to the model.

## 10.8 Review Questions

1. What do you understand by advanced animation tools?
2. Explain the image editing tools.
3. Describe the various types of image editing tools.
4. Explain the concept of sound editing tools.
5. Discuss the various types of sound editing tools.
6. What are the vital tools of 3D art work?

### Answers: Self Assessment

- |  |                          |
|--|--------------------------|
| 1. 3D modelling                              | 2. Rigging               |
| 3. Texturing                                 | 4. Animation             |
| 5. 3D rendering                              | 6. Modelling workflows   |
| 7. Vertices                                  | 8. Raster images         |
| 9. Painting programs                         | 10. Drawing programs     |
| 11. Vector-drawn objects                     |                          |
| 12. Retouching, airbrushing or Photoshopping |                          |
| 13. Photo manipulation                       | 14. Microsoft Picture It |
| 15. Digital Image Standard                   | 16. Digital Image Suite  |
| 17. Digital Image Suite Plus                 | 18. Paintbrush           |
| 19. Digitising                               | 20. Trimming             |
| 21. Splicing and Assembly                    | 22. Audacity             |
| 23. Audio Recorder                           |                          |

## 10.9 Further Readings



Books

Frederick P. Brooks, Jr., Kenan Professor of Computer Science, *The Mythical Man-Month: Essays in Software Engineering*, University of North Carolina at Chapel Hill.

K. Andleigh and K. Thakkar, *Multimedia System Design*, PHI, PTR.

Steve Rimmer (2000), *Advanced Multimedia Programming*, MHI.



Online links

[http://books.google.co.in/books?id=1odsKtv46ZQC&lpg=PA193&ots=muU4yj5Ab8&dq=Fundamental %20of %20Animations&pg=PA193#v=onepage&q&f=false](http://books.google.co.in/books?id=1odsKtv46ZQC&lpg=PA193&ots=muU4yj5Ab8&dq=Fundamental%20of%20Animations&pg=PA193#v=onepage&q&f=false)

<http://nora.lis.uiuc.edu:3030/companion/view?docId=blackwell/9781405103213/9781405103213.xml&doc.view=print&chunk.id=ss1-2-10&toc.depth=1&toc.id=0>

[http://users.mct.open.ac.uk/yr258/papers/Rogers\\_Scaife98.pdf](http://users.mct.open.ac.uk/yr258/papers/Rogers_Scaife98.pdf)

<http://www.icheg.org/icheg-game-history/timeline/>

<http://www.ict.griffith.edu.au/teaching/1611ICT/mm1alectures/111/Writing%20For%20Multimedia%20Great%20Moments%20In%20Multimedia%20History.htm>



## Unit 11: Compression

Notes

### CONTENTS

Objectives

Introduction

11.1 CODEC

11.2 Compression Quality

11.3 Types of Compression

11.3.1 Lossless Compression

11.3.2 Lossy Compression

11.4 Redundancies and its Types

11.4.1 Coding Redundancy

11.4.2 Interpixel Redundancy

11.4.3 Psychovisual Redundancy

11.5 Image Compression Models

11.5.1 Source Encoder and Decoder

11.5.2 Lossless Image Compression Model

11.5.3 Channel Encoder and Decoder

11.6 Summary

11.7 Keywords

11.8 Review Questions

11.9 Further Readings

### Objectives

After studying this unit, you will be able to:

- Define codec
- Describe compression quality
- Discuss redundancies and its types
- Understand image compression models

### Introduction

Compared to text files other media files like image, audio and video take up a huge amount of disk space. A typical five page document file occupy 75 KB of space, whereas a single image can take up about 1.4 MB, a 1 minute audio clip can take up over 10 MB and a 1 minute video clip can take up 2 GB of disk space. It is extremely difficult working with such huge Files mainly because of two reasons:

**Notes**

- Due to their huge sizes, storage requirements increases rapidly with multiple such media files thereby increasing the cost. During a multimedia development work, one can quickly run out of disk space.
- Even if there is adequate storage space, such files require a large data transfer rate that may be beyond the capabilities of both the processor and hard disk.



*Example:* To play back art audio file, the disk and processor have to process about 1.4 million bits of data per second.

Due to these facts it is customary to subject the media files to a process called compression. Compression reduces their file sizes using mathematical algorithms, after which it becomes much easier to manipulate these files. The amount of compression which can be achieved depends both on the original media data as well as the compression technique applied. There are various compression methods available and the compression factors can vary from two times to over ten times. In this unit we discuss the various methods of compression in detail.

### 11.1 CODEC

After an analog quantity has been digitized, it is stored on the disk as a digital file. Such files are referred to as raw or uncompressed media data. To compress the file and reduce its size, it needs to be filtered through a specialized software called a CODEC, which is short for Compression/Decompression or Coder/Decoder. The software reads the media data and applies mathematical algorithms to reduce its size, the algorithms work by trying to find redundant information within the media files. Redundant information are those which can either be discarded without affecting the media quality by appreciable measures, or data that can be expressed in a more compact form. In either case this leads to a reduction in file size, but the actual amount of reduction depends on a large number of factors involving both the media data and the CODEC used. The compressed media is then again stored on the disk or other storage media, frequently as a different type of file with another extension. When the media needs to be played back either as stand-alone or as part of a presentation, the same CODEC is again used to decompress the data which was previously compressed. Hence, the compression process needs to be essentially reversible. However, depending on the type of CODEC used, the decompressed data may or may not be exactly identical to the original uncompressed data. The decompression process is necessary because the playback devices like the monitor or speakers cannot directly handle compressed data. The decompression process usually takes place in the memory or buffer so that the original compressed file stays intact. After decompression, the raw digital data is usually converted to analog form before being played back.

There are numerous standard codec schemes. Some are used mainly to minimize file transfer time, and are employed on the Internet. Others are intended to maximize the data that can be stored in a given amount of disk space, or on a CD-ROM.



*Notes* Codecs are used in many popular Internet products, including QuickTime, Netmeeting, Cu-Seeme, and VDOphone.

### 11.2 Compression Quality



*Did u know?* The data compression ratio can serve as an measure of the complexity of a data set or signal, in particular it is used to approximate the algorithmic complexity.

Many of the files you view over an Internet connection reach your computer in compressed form. Files can be condensed using “lossy” or “lossless” compression. Lossy compression occurs when data is lost in the process of compression a file to transmit or store it. When files decompress on your computer, there is less data than there was before the file was sent from the server. This often happens with photos or graphics transmitted through the Web. After the file compression, the photo may not be as sharp or colorful as it was in its original form, but such compression greatly speeds up the transfer of data. Lossless compression allows files like text to remain completely intact during the transmission process.

### 11.3 Types of Compression

Data compression is the reduction or elimination of redundancy in data representation in order to achieve savings in storage and communication costs. Based on the methodologies compression can broadly be classified into two types:

1. Lossless Compression
2. Lossy Compression.

#### 11.3.1 Lossless Compression

Lossless compression implies the original data is not changed permanently during compression. After decompression therefore the original data can be retrieved back exactly. CODEC's used for lossless compression are called lossless CODEC's. The algorithms within these CODECs attempt to represent the existing information in a more compact form without actually discarding any data.

**Advantage:** The advantage of lossless compression is that the original data stay intact loci the degradation of qualities and can be reused.

**Disadvantage:** The disadvantage is that the compression achieved is not very high and may be typically of the order of two to five times.

Lossless compression is used where media quality is of utmost importance and the larger space requirements may be justified.



*Example:* Quality might play an important part in diagnosing faults from digitally stored medical images like X-ray plates and ultra-sonographs.

While lossless compression is always desirable images with very little redundancy do not produce acceptable compression results with this technique.

Lossless compression is also used when it is important that the original and the decompressed data be identical, or when no assumption can be made on whether certain deviation is uncritical. Typical examples are executable programs and source code. Some image file formats, notably PNG, use only lossless compression, while others like TIFF and MNG may use either lossless or lossy methods. GIF uses a lossless compression method, but most GIF implementations are incapable of representing full color, so they quantize the image (often with dithering) to 256 or fewer colors before encoding as GIF. Color quantization is a lossy process, but reconstructing the color image and then re-quantizing it produces no additional loss.

Lossless Compression typically is a process with three stages:

1. **The model:** the data to be compressed is analysed with respect to its structure and the relative frequency of the occurring symbols.

**Notes**

2. *The encoder:* produces a compressed bitstream/file using the information provided by the model.
3. *The adaptor:* uses information extracted from the data (usually during encoding) in order to adapt the model (more or less) continuously to the data.

**Lossless Compression Techniques**

Lossless compression methods may be categorized according to the type of data they are designed to compress. Some main types of targets for compression algorithms are text, executables, images, and sound. Whilst, in principle, any general-purpose lossless compression algorithm (general-purpose means that they can handle all binary input) can be used on any type of data, many are unable to achieve significant compression on data that is not of the form that they are designed to deal with. Sound data, for instance, cannot be compressed well with conventional text compression algorithms.

**Run-length Coding**

The basic principle is to replace sequences of successive identical symbols by three elements: a single symbol, a counter, and an indicator which gives the interpretation of the other two elements.



*Example:* We discuss the tape drive of the IBM AS/400 (where obviously lots of blanks are encountered): strings of consecutive blanks (2-63 byte) are compressed into a codeword which contains the information "blank" and a counter.

Strings of consecutive identical characters unequal blank (3-63 byte) are compressed into 2 byte: Control byte ("consecutive char" and counter) and character byte. Strings of non-consecutive identical characters are expanded by a control byte ("non-consecutive identical").



*Example:* b Blank, \* control byte; bbbbbbABCDEFbb33GHJKbMN333333 is compressed into \*\*ABCDEF\*\*33GHJKbMN\*3

**Huffman Coding**

A statistical compression method that converts characters into variable length bit strings. Most-frequently occurring characters are converted to shortest bit strings; least frequent, the longest. Compression takes two passes. The first pass analyzes a block of data and creates a tree model based on its contents. The second pass compresses the data via the model. Decompression decodes the variable length strings via the tree.

Huffman coding converts each sequence into binary first DC following with ACs. Huffman tables are specified in JPEG. Each (runlength, size) is encoded using Huffman coding. Each (amplitude) is encoded using a variable length integer code (1,4)(12) => (1111101101100)

**Huffman Encoding**

*Input:* ABACDEAACCAABEAABACBDDABCADDBCEAEAAADBE

Order-0 model

Symbol A B C D E

Count 15 7 6 6 5

total:  $39 \times 3 = 117$  bits

**Output:**  $15 \times 1 + (7 + 6 + 6 + 5) \times 3 = 87$  bits

**Compression ratio:**  $117 / 87 = 1.34$

Notes

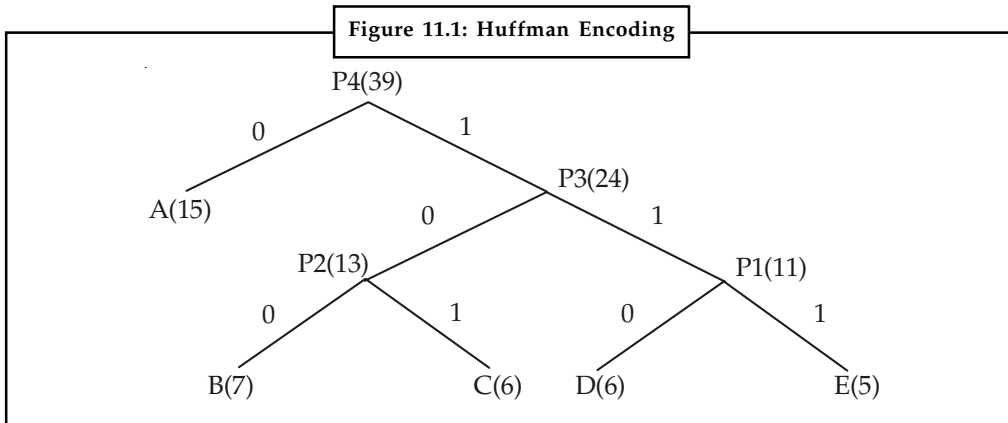

Source: <http://www.cs.cf.ac.uk/Dave/Multimedia/node207.html>

### Variable Length Coding

Variable length coding is a technique that sorts the symbols according to the frequency count of their occurrences and recursively divide the symbols into two parts, each with approximately the same number of counts, until all parts contain only one symbol.

### Lempel-Ziv Compression

(Lempel-Ziv-Welch) is a data compression method that stems from techniques introduced by Jacob Ziv and Abraham Lempel. LZW has been used in many hardware and software products, including V.42bis modems, GIF, TIF and PDF files and PostScript Level 2. The LZ77 method creates pointers back to repeating data, while LZ78 creates a dictionary of repeating phrases with pointers to those phrases.

Lempel-Ziv takes advantage of repetitive series of data, replacing them with a single codeword. This codeword will tell when the series previously occurred, how long it is, and will give a new piece of data that is not part of the series. The codeword will consist of the form: pointer, length, and last symbol. The pointer will represent where the start of the series previously occurred within a window of time. This will meet the requirements for the data compression. This cannot be used for the address compression since the address stream has almost no repetition.

Lempel Ziv Welch uses fixed-length code words to represent variable-length strings of symbols/characters that commonly occur together, e.g., words in English text. The LZW encoder and decoder build up the same dictionary dynamically while receiving the data.

LZW places longer and longer repeated entries into a dictionary, and then emits the code for an element, rather than the string itself, if the element has already been placed in the dictionary.



**Caution** If the data is not suited for run length encoding we result in data expansion (caused by the expansion of non-consecutive identical chars). Run length coding is extremely fast on the other hand and can compress quite well in case of suited data.

### 11.3.2 Lossy Compression

A compression technique that does not decompress data back to 100% of the original is termed as lossy compression. Lossy methods provide high degrees of compression and result in very small compressed files, but there is a certain amount of loss when they are restored. In Lossy compression techniques, parts of the original data are discarded permanently to reduce file size. After decompression the original data cannot be recovered which leads to a degradation of media quality. However if done correctly the quality loss may not be immediately apparent because of the limitations of the human eye and ears, and also because of the tendency of the human senses to bridge the gaps in information. An important consideration is how much information can be lost before the human eye can tell the difference. Compression ratios of the order of 10 to 50 times may be achieved by this method.

Audio, video and some imaging applications can tolerate loss, and in many cases, it may not be noticeable to the human ear or eye. In other cases, it may be noticeable, but not that critical to the application. The more tolerance for loss, the smaller the file can be compressed, and the faster the file can be transmitted over a network.



*Example:* Some of the lossy file formats are MP3, AAC, MPEG and JPEG. Lossy compression is usually used where media quality may be sacrificed to a certain extent for reducing space requirements, like in multimedia presentations and Web page content.

#### Transform Coding

Most standardised lossy media compression schemes are based on transform coding techniques. Typically, transformation based coding consists of three stages:

1. **Transformation:** It is used to map from one space to another along the graphics pipeline.
2. **Quantisation:** A variety of techniques (as discussed before) can be applied to map the transform coefficients to a small alphabet, the size of the latter being selected corresponding to the target bit rate. Most rate-control procedures are applied in this stage.
3. **Lossless encoding of coefficients:** A variety of techniques (as discussed before) is applied in order to encode the quantised transform coefficients close to the entropy bound. Typically, a combination of runlength (zero-runs !) and Huffman coding (for the older standards like JPEG, MPEG- 1, 2, 4) or arithmetic coding (for the more recent standards like JPEG 2000 H.264) is used.

#### Wavelet Transformation

The objective of the wavelet transform is to decompose the input signal into components that are easier to deal with, have special interpretations, or have some components that can be thresholded away, for compression purposes. We want to be able to at least approximately reconstruct the original signal given these components. The basic functions of the wavelet transform are localized in both time and frequency. There are two types of wavelet transforms: the continuous wavelet transform (CWT) and the discrete wavelet transform (DWT).

#### Quantisation

A fundamental issue for quantisation of transform coefficients is the strategy how coefficients are selected to be processed further:

1. **According to pre-defined zones in the transform domain:** For example, high frequency coefficients are severely quantised and low frequency components are protected (HVS modelling).

2. **According to magnitude:** Coefficients smaller than some threshold are ignored (disadvantage: location needs to be store somehow), or only L largest coefficients are kept in quantised form, etc. In fact, in most schemes both ideas are combined (e.g. JPEG).

Notes



Notes Lossy compression is never used for business data and text, which demand a perfect “lossless” restoration.

## Self Assessment

Fill in the blanks:

- ..... is the reduction in size of data in order to save space or transmission time.
- ..... takes advantage of repetitive series of data, replacing them with a single codeword.
- ..... compression implies the original data is changed permanently during compression.
- ..... is used to compress the executable code, text files and numeric data.
- To compress the file and reduce its size, it needs to be filtered through a specialized software called a .....

## 11.4 Redundancies and its Types

Redundancies can also be classified broadly into three types:

- Coding Redundancy = redundancy with respect to data representation
- Interpixel Redundancy = redundancy with respect to the image representation
- Psychovisual Redundancy = redundancy with respect to the image content

### 11.4.1 Coding Redundancy

Let's consider gray level image having  $n$  pixels. The number of gray levels in the image is  $L$  (i.e. the gray levels range from 0 to  $L-1$  and the number of pixels with gray level  $k$  is  $n_k$ ). Then the

probability of occurring gray level  $k$  is  $p(k) = \frac{n_k}{n}$ . If the number of bits used to represent the gray level  $k$  is  $l(k)$  then the average number of bits required to represent each pixel is

$L_{avg} = \sum_{k=0}^{L-1} l(k)p(k)$ . Hence the number of bits required to represent the whole image is  $n \times L_{avg}$ .

Maximal compression ratio is archived when  $L_{avg}$  is minimized (i.e. when  $l(k)$ , the length of gray level representation function, leading to minimal  $L_{avg}$ , is found). Coding the gray levels in such a way, that the  $L_{avg}$  is not minimized results in an image containing **coding redundancy**. Generally coding redundancy is presented when the codes (whose lengths are represented here by  $l(k)$  function) assigned to a gray levels don't take full advantage of gray levels' probability ( $p(k)$  function). Therefore it almost always presents when an image's gray levels are represented with a straight or natural binary code.

### 11.4.2 Interpixel Redundancy

*Interpixel redundancy* is another form of data redundancy, which is related to interpixel correlation within an image. Usually the value of certain pixel in the image can be reasonably predicted from the values of group of other pixels in the image.



*Example:* The gray levels of neighboring pixels are roughly the same and by knowing gray level value of one of the neighborhood pixels one has a lot of information about gray levels of other neighborhood pixels.

Thus the value of the individual pixel carries relatively small amount of information and much more information about pixel value can be inferred on the basis of its neighbors' values. These dependencies between pixels' values in the image are called *interpixel redundancy*.

In order to reduce the interpixel redundancies in the image, the 2-D pixel array of image values, used for image visualization should be transformed into another, generally "non-visual" representation. For our example above, such representation may be the value of leftmost top pixel along with 1-D array of differences between adjacent pixels. Transformations used to reduce the interpixel redundancies are called *mapping*. Since in this paper we deal only with lossless compression, the mappings, which will be considered further will be reversible. The basis of interpixel redundancy is repetition and prediction.

### 11.4.3 Psychovisual Redundancy

While interpixel redundancy originates within the image, audio and video data, psychovisual redundancy originates from the characteristics of the HVS. In the HVS, visual information is not perceived correctly, some information may be more important than other information. This implies that if we apply fewer data to represent less important visual information, perception will not be affected.



*Example:* Some colors in an image or specific sounds within an audio clip may not be detectable by human senses. Such information can be eliminated to reduce file size, without an appreciable variation in quality perception.

In psychovisual redundancy certain information simply has less relative importance than others in normal visual processing. The elimination of psychovisually redundant data results in a loss of quantitative information is called quantization.

Psychovisual redundancy is fundamentally different from the coding redundancy and interpixel redundancy. Unlike coding redundancy and interpixel redundancy, it is associated with real or quantifiable visual information. Its elimination is possible only because the information itself is not essential for normal visual processing. Since the elimination of psychovisual redundant data results in a loss of quantitative information. Thus it is an irreversible process.



*Notes* The elimination of psychovisually redundant data results in a loss of quantitative information is called quantization.

## 11.5 Image Compression Models

Usually all three types of redundancy reduction can be combined, e.g. a color reduced picture can be run length encoded, the run length code can be huffman encoded. Of course the decoding



of the dataset P2 achieved must be in reverse order: huffman decoding followed by inverse run length decoding. Note that the psychovisual reduction cannot be reversed, since the information is lost, so there's no decoding step for psychovisual reduction.

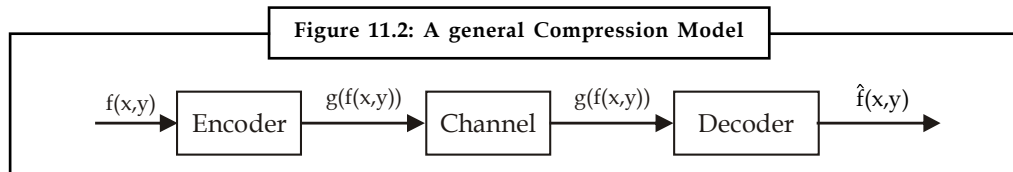

### 11.5.1 Source Encoder and Decoder

**Source Encoder:** The source encoder is responsible for reducing or eliminating any coding, interpixel, or psychovisual redundancies in the input image. The specific application dictates the best encoding approach. Normally, the approach can be modelled by a series of three independent operations. Operation is designed to reduce one of the three redundancies discussed earlier.

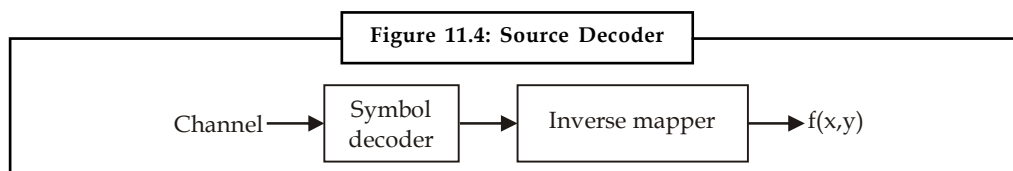
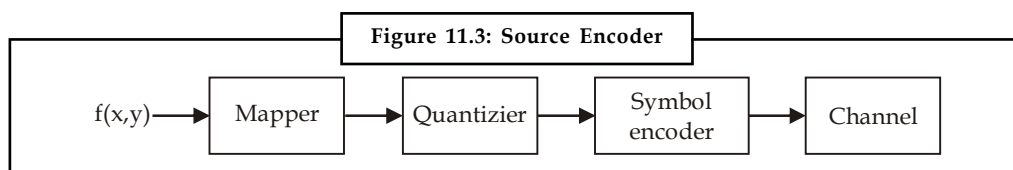

**Source:** <http://www.cs.ru.nl/~ths/rt2/col/h6/6compressieENG.html>

The encoder performs compression, the decoder performs decompression. Both operations can be done in software (web browsers, image viewers) or in a combination of hardware and firmware (DVD players, digital cameras). A codec is a device or program that is capable for both encoding and decoding.

#### Source Encoding (Compression) Process

1. **Mapper:** The mapper transforms an image (or their sequence) into a usually invisible format designed to reduce spatial and temporal redundancy. Usually, this operation is reversible and may or may not reduce the amount of data needed to represent the image. Run-length coding is an example of mapping. In video applications, the mapper uses previous (and future) frames to facilitate removal of temporal redundancy.
2. **Quantizer:** The quantizer reduces the accuracy of the mapper's output according to the fidelity criterion. This operation is irreversible and targets to remove irrelevant information from the image. When error-free compression is needed, this procedure must be omitted.
3. **Symbol Encoder:** The final stage of the encoding process, the symbol coder, generates a fixed- or variable-length code to represent the quantizer output according to the code. Usually, to minimize coding redundancy, the shortest code words are assigned to the most frequently occurring quantizer output values. This operation is reversible.

These three operations leads to removal (decreasing) of all three redundancies from the input image.

Notes

**Source Decoder:** The source decoder contains two components: symbol decoder and an inverse mapper performing the inverse operations of the encoder's symbol coder and mapper. The inverse quantizer block is not included since quantization is irreversible.

**11.5.2 Lossless Image Compression Model**

In two previous sections we introduced two techniques used to reduce amount of data needed to represent the image. Usually practical lossless image compression systems combine these techniques to achieve better compression ratios. Typical compression system consists of two parts: *encoder* and *decoder* (The input image  $f(x,y)$  is fed into encoder producing a set of symbols  $g(f(x,y))$  describing the image. Then this set of symbols is transmitted over noiseless communication channel and is fed into decoder, where  $\hat{f}(x,y)$ , a reconstructed output image is generated. Since we are dealing with lossless compression  $f(x,y)$  is an exact replica of  $\hat{f}(x,y)$ ).

The encoder is responsible for reducing or eliminating any coding or interpixel redundancies presented in the image. This is done by two independent operations, each one dealing with certain type of redundancy. The structure of encoder is depicted in Figure 11.5 (a) and the structure of corresponding decoder is depicted in Figure 11.5 (b).

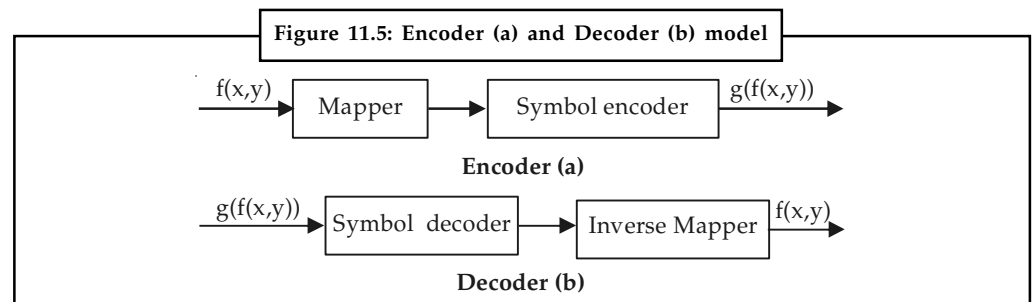

In the first stage of encoding interpixel redundancies are reduced or eliminated by *mapper*. The resulting data still contains coding redundancies, which are reduced or eliminated in the second stage by *symbol encoder*. Generally, mapper and encoder implement two independent algorithms, and to operate in one system they need to agree on the format of data interchanged between them.

The decoder works in reverse order, applying firstly *symbol decoding* (inverse operation to symbol encoding) and then *inverse mapper* to get the original image  $f(x,y)$ .

**11.5.3 Channel Encoder and Decoder**

The channel encoder and decoder plays an important role in reducing the impact of channel noise when the channel is noisy. As the output of the source encoder contains less redundancy, it would be highly sensitive to noise so the channel encoder introduces controlled form of redundancy into source encoder data to reduce the impact of noise. The important channel encoding technique used is Hamming code. This is based on appending enough bits to the data being encoded to ensure that in case of any error only some minimum number of bits must be changed to restore valid code words.



*Example:* Scientist Hamming showed that if three bits of redundancy are added to a 4-bit word, the distance between any two valid code words is three, and all single bits errors could be detected and corrected. The 7-bit Hamming code word is denoted as  $h_1, h_2, \dots, h_7$ . Out of these seven bits, four bits are used for information and they are denoted as  $b_3, b_2, b_1, b_0$ .



*Task* Write the steps involved in compressing a video clip and uploading it on a website.

Notes

## Self Assessment

Fill in the blanks:

6. A compression technique that does not decompress data back to 100% of the original is termed as .....
7. These dependencies between pixels' values in the image are called .....
8. The ..... reduces the accuracy of the mapper's output according to the fidelity criterion.
9. .... originates from the characteristics of the HVS.
10. .... is designed to reduce the impact of channel noise by inserting a controlled form of redundancy into the source encoded data.



*Case Study*

### A Brief History of Compression "If you think of it, it exists somewhere"

– David Byrne

**D**igital video compression techniques have played an important role in the world of telecommunication and multimedia systems where bandwidth is still a valuable commodity. Hence, video compression techniques are of prime importance for reducing the amount of information needed for picture sequence without losing much of its quality, judged by human viewers. Modern compression techniques involve very complex electronic circuits and the cost of these can only be kept to an acceptable level by high volume production of LSI chips (for a short introduction to how LSI chips are manufactured, visit Jim's site here). This means that we have to standardize the techniques of video compression.

The history of compression begins in the 1960s. An analogue videophone system had been tried out in the 1960s, but it required a wide bandwidth and the postcard-size black-and-white pictures produced did not add appreciably to voice communication! In the 1970s, it was realized that visual speaker identification could substantially improve a multiparty discussion and videoconference services were considered. Interest increased with improvements in picture quality and digital coding.

With the available technology in the 1980s, the COST211 video codec (Encoder/Decoder), based on differential pulse code modulation, DPCM (Pulse Code Modulation is still used in CD audio files, so they are called PCM/.wav files), was standardized by CCITT, under the H.120 standard. For more information on the history of conferencing, follow this link. This codec's target bitrate was 2 Mbit/s for Europe and 1.544 Mbit/s for North America, suitable for their respective first levels of digital hierarchy. However, the image quality, although having very good spatial resolution (due to the nature of DPCM working on a pixel-by-pixel basis), had a very poor temporal quality. It was soon realized that in order to improve the image quality, without exceeding the target bitrate, less than one bit

*Contd....*

## Notes

should be used to code each pixel. This was only possible if a group of pixels (a "block") were coded together, such that the bit per pixel is fractional. This led to the design of so-called block-based codecs.

During the late 1980s study period, of the 15 block based videoconferencing proposals submitted to the ITU-T (formerly the CCITT), 14 were based on the Discrete Cosine Transform (DCT) and only one on Vector Quantization (VQ). The subjective quality of video presented to the panel showed hardly any significant differences between the two coding techniques. In parallel to ITU-T's investigation during 1984-88, the Joint Photographic Experts Group (JPEG) was also interested in compression of static images. They chose the DCT as the main unit of compression, mainly due to the possibility of progressive image transmission. JPEG's decision undoubtedly influenced the ITU-T in favouring DCT over VQ. By now there was a worldwide activity in implementing the DCT in chips and on DSPs.

In the late 1980s it was clear that the recommended ITU-T videoconferencing codec would use a combination of interframe DPCM for minimum coding delay and the DCT. The codec showed greatly improved picture quality over H.120. In fact, the image quality for videoconferencing applications was found reasonable at 384 kbit/s or higher and good quality was possible at significantly higher bitrates if around 1 Mbit/s. This effort was later extended to systems based on multiples of 64 kbit/s (upto 30 multiples of this value). The standard definition was completed in late 1989 and is officially called the H.261 standard, and the coding method is referred to as the " $p \times 64$ " method ( $p$  is an integer between 1 and 30).

In the early 1990s, the Motion Picture Experts Group (MPEG) started investigating coding techniques for storage of video, such as CD-ROMs. The aim was to develop a video codec capable of compressing highly active video such as movies, on hard disks, with a performance comparable to that of VHS quality. In fact, the basic framework of the H.261 generation of MPEG, called the MPEG-1 standard, was capable of accomplishing this task at 1.5 Mbit/s. Since for the storage of video, encoding and decoding delays are not a major constraint, one can trade delay for compression efficiency. For example in the temporal domain a DCT might be used rather than DPCM, or DPCM used but with much improved motion estimation, such that the motion compensation removes temporal correlation. This later option was adopted with MPEG-1.

These days, MPEG-1 decoders/players are becoming common place for multimedia on computers. The MPEG-1 decoder plugin hardware boards (e.g., MPEG magic cards) have been around for a while, and now software MPEG-1 decoders are available with the release of operating systems or multimedia extensions for PC and Mac platforms. Since in all standard video codecs, only the decoders have to comply with proper syntax, software based encoding has added the extra flexibility that might even improve the performance of MPEG-1 in the future.

The MPEG-1 was originally optimized for typical applications using non-interlaced video of 25 frames per second (fps), in European format and 29.9 fps in North American format, in the range of 1.2-1.5 Mbit/s for image quality comparable to home VCRs, it can certainly be used at higher bit rates and resolutions. Early versions of MPEG-1 for interlaced video, such as those used in broadcast, were called MPEG1+. A new generation of MPEG, called MPEG-2 was soon adopted by broadcasters (who were initially reluctant to use any compression on video!). The MPEG-2 codes for interlaced video at bit rates 4-9 Mbits/s, and is now well on its way to making a significant impact in a range of applications such as digital terrestrial broadcasting, digital satellite TV, digital cable TV, digital versatile

Contd....

## Notes

disc (DVD) and many others. Television broadcasters have started using MPEG-2 coded digital forms since the late 1990s.

A slightly improved version of MPEG-2, called MPEG-3, was to be used for coding of High Definition (HD) TV, but since MPEG-2 could itself achieve this, MPEG-3 standards were folded into MPEG-2.

It is foreseen that by 2014, the existing transmission of NTSC North America format will cease and instead HDTV with MPEG-2 compression will be used in terrestrial broadcasting.

**Questions:**

1. Comment on Digital video compression techniques.
2. What led to the designing of block-based codecs?

Source: <http://www.pha.jhu.edu/~sundar/intermediate/history.html>

**11.6 Summary**

- Data compression is the reduction or elimination of redundancy in data representation in order to achieve savings in storage and communication costs.
- Data compression techniques can be broadly classified into two categories: Lossless, Lossy schemes.
- Lossless data compression make use of data compression algorithms that allows the exact original data to be reconstructed from the compressed data.
- Lossy data compression, which does not allow the exact original data to be reconstructed from the compressed data.

**11.7 Keywords**

**Compression:** Compression is the reduction in size of data in order to save space or transmission time.

**CODEC:** A microchip that compresses or decompresses data is called CODEC.

**Lossless Compression:** A compression technique that decompresses data back to its original form without any loss. The decompressed file and the original are identical.

**Lossy compression:** Lossy compression is where some quality is lost to achieve greater compression but the loss is not noticeable.

**Mapper:** The mapper is the process that transforms an image (or their sequence) into a usually invisible format designed to reduce spatial and temporal redundancy.

**Source encoder:** The source encoder is responsible for reducing or eliminating any coding, interpixel or psychovisual redundancies in the input image.

**11.8 Review Questions**

1. What are the ways to implement multimedia compression systems?
2. Explain CODEC.
3. What are the types of Compression?
4. Explain in detail the lossless compression.

**Notes**

5. Describe the types of redundancies.
6. Explain the image compression model.
7. What are the steps involved in source encoding?
8. Explain the lossless image compression model with appropriate diagrams.

**Answers: Self Assessment**

- |                            |                                 |
|----------------------------|---------------------------------|
| 1. Compression             | 2. Lempel-ziv                   |
| 3. Lossy                   | 4. Lossless compression         |
| 5. CODEC                   | 6. Lossy compression            |
| 7. Interpixel redundancy   | 8. Quantizer                    |
| 9. Psychovisual redundancy | 10. Channel encoder and decoder |

**11.9 Further Readings**



*Books*

Frederick P. Brooks, Jr., Kenan Professor of Computer Science, *The Mythical Man-Month: Essays in Software Engineering*, University of North Carolina at Chapel Hill.

K. Andleigh and K. Thakkar, *Multimedia System Design*, PHI, PTR.

Steve Rimmer (2000), *Advanced Multimedia Programming*, MHI.

Tay Vaughan, *Multimedia Making it work*, Seventh Edition, Tata McGraw-Hill Education Private Ltd.



*Online links*

<http://202.194.26.100/web/dip/0907/02.pdf>

<http://nora.lis.uiuc.edu:3030/companion/view?docId=blackwell/9781405103213/9781405103213.xml&doc.view=print&chunk.id=ss1-2-10&toc.depth=1&toc.id=0>

<http://notesofgenius.com/multimedia-compression/>

[http://users.mct.open.ac.uk/yr258/papers/Rogers\\_Scaife98.pdf](http://users.mct.open.ac.uk/yr258/papers/Rogers_Scaife98.pdf)

<http://www.icheg.org/icheg-game-history/timeline/>

<http://www.ict.griffith.edu.au/teaching/1611ICT/mm1alectures/111/Writing%20For%20Multimedia%20Great%20Moments%20In%20Multimedia%20History.htm>

<http://www.slideshare.net/pareshkamble/image-compression-12093925>

## Unit 12: Image Format

Notes

### CONTENTS

Objectives

Introduction

12.1 Basics of Image Format

12.1.1 Classification

12.1.2 Uses

12.1.3 Why People Have to be Aware of the Different Image Formats

12.1.4 Which Vector Programs You Need to Use

12.1.5 Image Compression

12.2 Image Formats Types

12.2.1 Bitmapped Graphics

12.3 Graphic Interchange Format (GIF)

12.3.1 Why Use GIF?

12.3.2 File Extension and Others Notes

12.4 Joint Photographic Experts Group (JPEG)

12.4.1 Status

12.4.2 Why Use JPEG?

12.4.3 File Extension and Others Notes

12.5 Moving Picture Experts Group (MPEG)

12.5.1 MPEG Standards

12.6 Fractal Image Compression

12.6.1 What is Fractal Image Compression

12.7 Summary

12.8 Keywords

12.9 Review Questions

12.10 Further Readings

### Objectives

After studying this unit, you will be able to:

- Understand the basics of image format
- Describe the image formats types
- Explain the graphic interchange format (GIF)
- Understand the joint photographic experts group (JPEG)

Notes

- Enumerate the moving picture experts group (MPEG)
- Discuss the fractal image compression

## Introduction

A single still video image, whether created by a drawing or paint program or scanned from a book or grabbed with a video camera, can be stored in any of a wide variety of file formats. The data will be stored in a raster or a vector file format. A raster image is one composed of a field of pixels, each characterized by a colour, and is usually created in paint programs, by scanning a picture or by grabbing an image. A vector format is created almost always by a drawing/CAD program and consists not of pixels, but objects such as curves, shades, and characters.

Raster formats can be generally separated into two categories. Lossy formats lose resolution (sharpness) when converted to, while lossless formats preserve image information.



*Example:* When converting from a GIF (lossless) to a JPEG (lossy), some information is lost. However, lossy formats tend to be much smaller than their lossless counterparts, and for most photographic images, there will be almost no subjective difference.

The following list of image file formats is not inclusive, but describes the formats that comprise the majority of files encountered on the Internet.

.gif, .jpg, .jpeg, .jfif, .ps, .eps, .epsi, .pdf, .tif, .tiff, .tga, .pict, .bmp, .pcx, .pbm, .ppm, .pgm, .psd, .cvs, .cgm, .wpg, .wmf and .xpm, .xbm.

Different file formats work with different programs, although almost all drawing/paint programs will read and write JPEG, GIF, and TIFF formats. GIF and JPEG formats are popular for FTP and the www because they are much smaller than other formats, so more of them can be stored. GIF and JPEG formats are not compressible, so it is generally a waste of effort to run a compression program on them. However, other file formats often compress by large amounts. PICT and TIFF formats work best with word processing and desktop publishing programs like Microsoft Word 6.0 and Adobe PageMaker 6.0.

## 12.1 Basics of Image Format

Simply by navigating on the Internet, you see how many image formats are available to you: BMP, GIF, JPEG, PNG, RAW, SVG, TIFF, . . . You can directly store an image of this kind on your hard disk, without thinking about the size it could take, or the further use(s) of this image. A recurrent problem is that people do confound these formats, and their specific properties, resulting in inappropriate image encoding choices, and aberrant behaviour.

These choices have (sometimes important) consequences for further uses of these images, and we here want to summarize the most important formats and the raster-vector classification to avoid this kind of naive reactions.

### 12.1.1 Classification

We can categorize image formats in two categories: raster and vector.

**Raster Images:** Raster image formats store images as bitmaps (also called "pixmap"). Briefly, a raster graphics image or bitmap is a data structure representing a generally rectangular grid of pixels, or points of colour. The main problem of the raster image format is that the graphics are resolution-dependent.



Because of this, a raster image cannot be scaled to a higher resolution (than the original one) without a given loss of quality. Depending on the desired image resolution, a loss of apparent quality is often observed.

Some kinds of raster images are BMP, GIF, JPEG, PNG, RAW, TIFF. We give a description of these ones in Table 12.1.

**Vector Images:** Vector image formats store images as vectors. We know that a vector is defined by three main properties: a direction, a magnitude, and a sense.

Thus, vector image formats contain a geometric description which can be rendered smoothly at any desired display size, although these files do not have a big size.

Vector file formats can contain bitmap data as well.

Some kinds of vector images are CGM, EPS, SVG. We give a description of these ones in Table 12.2.

**Table 12.1. Comparison of the main image raster formats**

Extension	Acronym	Description	Advantages	Disadvantages
BMP	Windows Bit Map	Handles graphics files within the Microsoft OS.	Wide acceptance and use in Windows programs.	BMP files are large (uncompressed).
GIF	Graphics Interchange Format	Supports 256 colours, colour depending, widely used to provide image animation effects.	Supports animation.	Limited to 256 colours; No real role compared to other formats.
JPEG	Joint Photographic Experts Group	Supports 8 bits by color, for a 24-bit total; Habitually lossy.	Small files; Compression does not noticeably detract from the image's quality.	
PNG	Portable Network Graphics	Supports truecolour (16 million colours), Best suited for editing pictures; Lossless.	Excels when the image has large, uniformly coloured areas; Robust.	Many older browsers currently do not support the PNG file format.
RAW	N.A.	Family of raw image formats; Available on some digital cameras.		Not standardized/ documented; Differ among camera manufacturers.
TIFF	Tagged Image File Format	Normally saves 8 or 16 bits per colour; Lossy; Lossless.	Widely accepted as a photograph file standard.	Not well supported by web browsers.

## Notes

Table 12.2. Comparison of the main image vector formats

Extension	Acronym	Description	Advantages	Disadvantages
CGM	Computer Graphics Metafile	2D vector graphics, raster graphics, text		Superseded by DXF, SVG formats.
EPS	Encapsulated PostScript	Used for compatibility with PS documents.	Interesting for good-looking documents.	
SVG	Scalable Vector Graphics	Open standard; Versatile; Scriptable; All-purpose for the web and otherwise; Key component in web applications: interactive web pages; Lossy; Lossless.	No compression scheme of its own, but thanks to XML, an SVG graphic can be compressed using a program such as gzip.	

Notice that lossless and lossy characteristics were not respectively put in “Advantages” and “Disadvantages” categories, because being lossy can be an advantage, and being lossless can be a drawback.

### 12.1.2 Uses

The best way to know which format file you have to choose for your images is to think about their further use. Here are some basic rules.

1. If these images need to be retouched, and modified, it is always better to keep them in their original resolution, until they are published;
2. When raster images are published, save them with an adapted resolution: e.g. if they only need to be reused as a button, do not save them at a high resolution, and reciprocally;
3. For picture distribution, choose JPG files, which are generally smaller than PNG ones;
4. If you work with coloured images which have large and uniformly coloured areas, choose the PNG format (if possible);
5. If you work with vector images, never save them as raster images;
6. Ideally, all diagrams, graphics and shapes should only be saved in vector format.

Concerning the point 3, another advantage of this technique is that, as JPG images are of less quality than the PNG original files, they cannot be scaled to a higher resolution without making imperfections visible. By this way, people cannot for example make posters of the pictures you worked on if you do not want them to.

The GIF format is still used, because suitable for storing graphics with relatively few colours such as cartoon style images. It is also useful for simple diagrams, logos and shapes, but it is here preferred to use vector format.

All the given points are often respected, except the 1, 5, and 6 ones. An effort must be done to avoid this kind of situations.

### 12.1.3 Why People Have to be Aware of the Different Image Formats

Notes

As discussed previously, the way an image is redistributed has a big influence on it. For a picture, if it is too highly compressed, it can have no interest, and, for a plain web button, there is no interest in using a high resolution, but an interest to use a vector format. Furthermore, if graphics are saved as raster images, and if they need to be put in a good-looking document, they must be re-plotted. It is essentially tedious when graphics are complex. It is not the case if the graphics are in a vector format.

*On the Internet:* When surfing on the Internet, we encounter too often heavy pages, albeit these pages do only have a small amount of tiny images. Then, by loading the images independently, we notice that the webmaster has simply reduced the displaying size of the image by modifying HTML img properties (attributes height and width), and that the linked image file has a size of 1 or 2 Mo.

*Anyway, this problem is solved in a simple way:* Using size-adapted miniatures for this kind of web pages, and original images if needed, e.g. available when clicking on the miniatures.

If this principle was respected on every website, the web-surfing could be more profitable to everybody, for evident reasons.

#### 12.1.4 Which Vector Programs You Need to Use

*Raster Images:* Raster images must not be “boycotted:” they have significant advantages that must be taken into account, but for specific uses (which were given at 1.2), and never for scientific croquis.

Numerous programs have been created for creating and editing raster images. Among them, we can cite “The GIMP” (see <http://www.gimp.com>), under GNU license, which currently deals with GIF, JPEG, PNG, PSD, and TIFF formats. There are almost comprehensive lists about this kind of programs on the Internet, whatever your O.S., and, furthermore, such programs are often pre-installed in a given O.S.

*Vector Images:* Vector images programs are still more hidden. Some good examples are “LaTeXdraw” (see <http://latexdraw.sourceforge.net>) and “Xfig” (consider <http://www.xfig.org/>).



*Caution* People must be aware of the different image formats, and their main properties, to enjoy a maximum the digital Computer-Assisted Publication (C-AP).

#### 12.1.5 Image Compression

The objective of image compression is to reduce irrelevance and redundancy of the image data in order to be able to store or transmit data in an efficient form. It is a process intended to yield a compact representation of an image, thereby reducing the image storage/transmission requirements.

The objective of compression is to reduce the number of bits as much as possible, while keeping the resolution and the visual quality of the reconstructed image as close to the original image as possible. Image compression systems are composed of two distinct structural blocks : an encoder and a decoder.

**Notes**

There are various benefits of image compression such as it provides a potential cost savings associated with sending less data over switched telephone network where cost of call is really usually based upon its duration. It not only reduces storage requirements but also overall execution time. It also reduces the probability of transmission errors since fewer bits are transferred. It also provides a level of security against illicit monitoring.

## **12.2 Image Formats Types**

One of the initial decisions you have to make as you are creating graphics for your presentations or pages is what files formats to use for your graphics. File formats break down into two categories: bitmapped and structured or vector.

### **12.2.1 Bitmapped Graphics**

The BMP file format, also known as bitmap image file or device independent bitmap (DIB) file format or simply a bitmap, is a raster graphics image file format used to store bitmap digital images, independently of the display device (such as a graphics adapter), especially on Microsoft Windows and OS/2 operating systems.

The BMP file format is capable of storing 2D digital images of arbitrary width, height, and resolution, both monochrome and colour, in various colour depths, and optionally with data compression, alpha channels, and colour profiles.

*Pixel Format:* In a bitmap image file on a disk or a bitmap image in memory, the pixels can be defined by a varying number of bits.

- The 1-bit per pixel (1bpp) format supports 2 distinct colours, (for example: black and white). The pixel values are stored in each bit, with the first (left-most) pixel in the most-significant bit of the first byte. Each bit is an index into a table of 2 colours. An unset bit will refer to the first colour table entry, and a set bit will refer to the last (second) colour table entry.
- The 2-bit per pixel (2bpp) format supports 4 distinct colours and stores 4 pixels per 1 byte, the left-most pixel being in the two most significant bits (Windows CE only). Each pixel value is a 2-bit index into a table of up to 4 colours.
- The 4-bit per pixel (4bpp) format supports 16 distinct colours and stores 2 pixels per 1 byte, the left-most pixel being in the more significant nibble. Each pixel value is a 4-bit index into a table of up to 16 colours.
- The 8-bit per pixel (8bpp) format supports 256 distinct colours and stores 1 pixel per 1 byte. Each byte is an index into a table of up to 256 colours.
- The 16-bit per pixel (16bpp) format supports 65536 distinct colours and stores 1 pixel per 2 byte WORD. Each WORD can define the alpha, red, green and blue samples of the pixel.
- The 24-bit pixel (24bpp) format supports 16,777,216 distinct colours and stores 1 pixel value per 3 bytes. Each pixel value defines the red, green and blue samples of the pixel (8.8.8.0.0 in RGBAX notation). Specifically in the order (blue, green and red, 8-bits per each sample).
- The 32-bit per pixel (32bpp) format supports 4,294,967,296 distinct colours and stores 1 pixel per 4 byte DWORD. Each DWORD can define the Alpha, Red, Green and Blue samples of the pixel.

**Usage of BMP Format:** The simplicity of the BMP file format, and its widespread familiarity in Windows and elsewhere, as well as the fact that this format is relatively well documented and free of patents, makes it a very common format that image processing programs from many operating systems can read and write.

Many older graphical user interfaces used bitmaps in their built-in graphics subsystems; for example, the Microsoft Windows and OS/2 platforms' GDI subsystem, where the specific format used is the Windows and OS/2 bitmap file format, usually named with the file extension of .BMP or .DIB.

While most BMP files have a relatively large file size due to lack of any compression (or generally low-ratio run-length encoding on palletized images), many BMP files can be considerably compressed with lossless data compression algorithms such as ZIP because they contain redundant data. Some formats, such as RAR, even include routines specifically targeted at efficient compression of such data.

### 12.3 Graphic Interchange Format (GIF)

Internet service provider CompuServe introduced GIF (Graphics Interchange Format) in 1987 as a format to transmit images with up to 256 different colours, replacing their earlier RLE format which was black and white only. In 1989 a revised specification was published that added some features to the format.

The original version of GIF was 87a (or GIF87a). In 1989, CompuServe devised an enhanced version, called 89a (or GIF89a), that added support for multiple images in a stream and storage of application-specific metadata. The two versions can be distinguished by looking at the first six bytes of the file, which, when interpreted as ASCII, read "GIF87a" and "GIF89a", respectively.

**GIF is palette based:** although any colour can be one of millions of shades, the maximum number of colours available is 256, which are stored in a 'palette', a table which associates each colour number with an actual colour value. The limitation to 256 colours seemed reasonable at the time of GIF's creation because few people had the hardware to display more. Typical line drawings, cartoons, grey scale photographs, and similar graphics need only 256 colours. There exist ways to dither colour photographs by alternating pixels of similar colours to approximate an in-between colour, but this transformation inevitably loses some detail, and the algorithms to select colours and to perform the dithering vary widely in output quality, giving dithering a possibly unwarranted bad reputation.

Additionally, dithering significantly reduces the image's compressibility and thus works contrary to GIF's main purpose. A variation using the multiple images feature to draw each scan line in a separate palette can store any RGB colour out of 16 million, but this takes even more space than an uncompressed Windows bitmap and is useful only where lossless true colour is required. This variation works only for some viewers. Such images will seem defective on viewers with differing interpretations of the GIF specification regarding transparency and local palettes.

**Interlacing:** The interlacing feature in a GIF file creates the illusion of faster loading graphics. What happens is that an image is presented in a browser in several steps. At first it will be fuzzy and blurry, but as more information is downloaded from the server, the image becomes more and more defined until the entire image has been downloaded. Very similar to the interlaced GIF is the Progressive JPEG. Interlacing is best for larger GIF images such as illustrations and photographs. Interlacing is a poor choice for small GIF graphics such as navigation bars, buttons, and icons. This was quite useful in the past since many users (especially home users) were on dial-up access where the bandwidth is very limiting. Users with faster connections are not likely to notice the difference.

Notes

**Transparency:** GIF (89a) allows transparent pixels. The transparency feature allows a graphic designer to designate the background of the image transparent. One colour entry in a single GIF or PNG image's palette can be defined as "transparent" rather than an actual colour. This means that when the decoder encounters a pixel with this value, it is rendered in the background colour of the part of the screen where the image is placed, also if this varies pixel-by-pixel as in the case of a background image.

**Animation:** GIF (89a) is the only widely used image format to support animation, unless you want to use FLASH or other vector-based animation formats. GIF provides an effective way of distributing small animations. A GIF file can contain more than one image. With certain software packages (most web browsers and image viewers), multiple-image GIFs can be played back as animations. It can even be used to distribute film clips of very low resolution and short length (there is no way to include sound).

### 12.3.1 Why use GIF?

The GIF format is particularly suited to rendering images that contain large blocks of the same colour, or large blocks of repeating patterns. Additionally, it does not suffer from the lossiness that leaves JPEG unable to display flat, clean, colour without losing all compression. Therefore, whenever a logo is seen on the internet, chances are that it is a GIF. For the same reason as GIF is generally used for logos so it is used for web page elements. Bevels, background patterns, borders, and other decoration are often in the .gif format.

If it is necessary to use transparency. Adding transparency to a GIF graphic can produce disappointing results when the image contains anti-aliasing. If you use an image-editing program to create a shape set against a background colour, this program will smooth the shape by inserting pixels of intermediate colours along the shape's boundary edges. This smoothing, or anti-aliasing, improves the look of screen images by softening jagged edges. Trouble starts when you set the background colour to transparent and then use the image on a Web page against a different background colour. The anti-aliased pixels in the image will still correspond to the original background colour.

The most web browsers can display GIF animation without the need for any extra plugins, also, the GIF files containing the animations are compressed, and will download quickly. GIF animation is good for small image animations on a web page, and for short animation sequences.

To conserve bandwidth, do whatever you can to make your image compact and small. The most common method of reducing the size of GIF files is to reduce the number of colours on the palette. The strategy is to reduce the number of colours in your GIF image to the minimum number necessary and to remove stray colours that are not required to represent the image. A GIF graphic cannot have more than 256 colours but it can have fewer colours, down to the minimum of two (black and white). Images with fewer colours will compress more efficiently under GIF compression. Not all software will let you set the bits per pixel for GIF or the colours of the palette. Also, you should use a global palette whenever possible for all images in a GIF animation, instead of local palette with each image inside it.

Where Gifs are not used:

- **Photographs.** Owing to the general restriction on the number of available colours in a single GIF image to 256 (although these 256 colours can be any of 16 million possibilities) the GIF format is unsuited to large colour photographs. It may however be acceptable for smaller (less than 500 pixels) photographs with less colours. Digital photographs commonly use the JPEG format.

### 12.3.2 File Extension and Others Notes

Notes

.GIF:..... GIF image.

The MIME media type for GIF is image/gif (defined in RFC 1341).

Web Browsers Support: All latest versions of browsers support GIF format.

GIF Patent Software Information.

GIF became popular because it used LZW data compression (Lempel-Ziv-Welch, 1984), which was more efficient than the run-length encoding that formats such as PCX and MacPaint used, and fairly large images could therefore be downloaded in a reasonable amount of time, even with very slow modems. The LZW compression scheme is best at compressing images with large fields of homogeneous colour. It is less efficient at compressing complicated pictures with many colours and complex textures.

It was only later that people found out that LZW, the compression algorithm used to store the image data within GIF, was patented by Unisys (IBM also).

When GIF finally became popular, Unisys started charging license fees for creating software that writes GIF files, even website owners who used GIF images on their site. This eventually triggered the development of PNG, the Portable Network Graphics image file format, in 1995, meant as a replacement for GIF. However, mediocre support of PNG in browsers kept GIF from becoming extinct.

The LZW Unisys patent expired on 20 June 2003 in the USA, in Europe it expired on 18 June 2004, in Japan patent expired on 20 June 2004 and in Canada it expired on 7 July 2004. The U.S. IBM patent will expire 11 August 2006.

Decoding GIF is a different issue. The Unisys and IBM patents are both written in such a way that they do not apply to a program which can only uncompressed LZW format and cannot compress. Therefore it can include support for displaying GIF files in GNU software (GNU is a recursive acronym for " GNU's Not UNIX ").

### Self Assessment

State whether the following statements are true or false:

1. Decompression is a computer term that represents a variety of mathematical formats used to compress an image's byte size.
2. Vector file formats can also contain bitmap data.
3. Preferably, all diagrams, graphics and shapes should only be saved in raster format.
4. LZW, the compression algorithm used to store the image data within GIF, was patented by Unisys (IBM also).
5. Bitmapped graphics work by saving the colour information for every pixel of the image.

### 12.4 Joint Photographic Experts Group (JPEG)

JPEG is an abbreviated form of Joint Photographic Experts Group, the independent committee that created it as a standard for photography compression, which was approved in 1994 as ISO 10918-1. The JPEG standard refers to both the technique for compressing an image into a stream of bytes and then decompressing it back close to its original form, and the file format holding that stream.

## Notes

The JPEG image file format has become popular for offering an amazingly effective compression method for colour images. It helps images to be compressed to about five per cent of their original size, which allows for minimized traffic consumption for websites using JPEG images. The complex compression algorithm allows the customers to create smaller graphics by losing some of the quality of the image. Although this is known to be a lossy compression, meaning that some image details are lost while the image is being compressed, any quality changes are usually invisible to the human eye.

Generally, you can control the compression quality results by choosing from a range of compression algorithms when creating a JPEG file or converting an image from another format to JPEG. The resulting quality of a JPEG image after decompression is proportional to its size, so, the bigger you choose it to be, the more preserved its original properties will remain.

The JPEG compression standard also supports a separate lossless mode. However, it has not managed to replace the lossy mode since it does not provide the same maximum levels of compression and hence – optimum image size decrease.

Thanks to its effective compression technique, JPEG is most widely used for storing and transmitting full colour and grey-scale digital images and paintings that represent scenes from the real world with eye-pleasing smooth tone variations.

JPEG supports several image file formats. The most commonly employed of them are JPEG/Exif, used by most photographic image capture devices, such as digital cameras, and most image editing programs, and JPEG/JFIF. Both formats are known for allowing photographic images to be stored and quickly transmitted over the Internet and are most commonly referred to as simply JPEG.

The images stored in a JPEG format could have one of the following file extensions: .JPG, .JPEG, .JFIF, .JIF .or .JPE.

### 12.4.1 Status

The JPEG compression format was standardised by ISO in August 1990 and commercial applications using it began to show up in 1991. The widely used IJG implementation was first publicly released in October 1991 and has been considerably developed since that time. JPEG JFIF images are widely used on the Web. The amount of compression can be adjusted to achieve the desired trade-off between file size and visual quality.

Progressive JPEG is a means of reordering the information so that, after only a small part has been downloaded, a hazy view of the entire image is presented rather than a crisp view of just a small part. It is part of the original JPEG specification, but was not implemented in Web browsers until rather later on, around 1996. It is now fairly widely supported.

Although the “baseline” variety of JPEG is believed patent-free, there are many patents associated with some optional features of JPEG, namely arithmetic coding and hierarchical storage. For this reason, these optional features are never used on the Web.

### 12.4.2 Why Use JPEG?

*There are two good reasons:* To make your image files smaller, and to store 24-bit-per-pixel colour data instead of 8-bit-per-pixel data.

Making image files smaller is a win for transmitting files across networks and for archiving libraries of images. JPEG can easily provide 20:1 compression of full-colour data. If you are comparing GIF and JPEG, the size ratio is usually more like 4.



JPEG is essentially a time/space trade-off: you give up some time (to code/decode) in order to store or transmit an image more quickly or cheaply. The time savings from transferring a shorter file can be greater than the time needed to decompress the file.

The second fundamental advantage of JPEG is that it stores full colour information: 24 bits/pixel (16 million colors). GIF, the other image format widely used on the net, can only store 8 bits/pixel (256 or fewer colours). Hence JPEG is considerably more appropriate than GIF for use as a World Wide Web standard photo format. The real disadvantage of lossy compression is that if you repeatedly compress and decompress an image, you lose a little more quality each time.

### 12.4.3 File Extension and Others Notes

.JPG:..... JPEG image.

.JPE:..... JPEG image.

.JPEG:.... JPEG image.

.JP2:..... JPEG-2000 JP2 file format image format.

.JPC:..... JPEG-2000 code stream image format.

The MIME media type for JFIF is image/jpeg.

A Progressive JPEG is the JPEG equivalent of the interlaced GIF Graphics Interchange Format. It is an image created using the JPEG suite of compression algorithms that will “fade in” in successive waves of lines until the entire image has completely arrived. A progressive JPEG is a more appealing way to deliver an image at modem connection speeds. The user should see a gradual improvement of the quality of the image. This was quite useful in the past since many users (especially home users) were on dial-up access where the bandwidth is very limiting. Users with faster connections are not likely to notice the difference.



*Notes* Web Browsers Support: All latest versions of browsers support JPEG format.

**Evolution of standard:** JPEG 2000. Is a new image coding system that uses state-of-the-art compression techniques based on ‘*wavelet technology*’ (ISO/IEC IS 15444 | ITU-T T.800 [2.21MB]), and as well as being better at compressing images (up to 20 per cent plus), it can allow an image to be retained without any distortion or loss.

**Wavelet technology** differs from the original JPEG strategy in the way it summarizes groups of pixels. One of the original JPEG compression algorithms, *discrete cosine transformation*, saved groups of eight pixels as individual blocks. Wavelet technology substitutes wavelets for blocks.



*Task* How to decide the correct format for an image?

## 12.5 Moving Picture Experts Group (MPEG)

The Moving Picture Experts Group (MPEG) is a working group of experts that was formed by ISO and IEC to set standards for audio and video compression and transmission. The first MPEG meeting was in May 1988 in Ottawa, Canada. As of late 2005, MPEG has grown to include approximately 350 members per meeting from various industries, universities, and research institutions. MPEG’s official designation is ISO/IEC JTC1/SC29 WG11 – Coding of moving pictures and audio (ISO/IEC Joint Technical Committee 1, Subcommittee 29, Working Group.

**Notes**

Moving Picture Experts Group (MPEG) standards are digital video encoding processes that coordinate the transmission of multiple forms of media (multimedia). MPEG is a working committee that defines and develops industry standards for digital video systems. These standards specify the data compression and decompression processes and how they are delivered on digital broadcast systems. MPEG is part of International Standards Organization (ISO).

The MPEG system defines the components (such as a media stream or channel) of a multimedia signal (such as a digital television channel) and how these channels are combined, transmitted, received, separated, synchronized and converted (rendered) back into a multimedia format. The basic components of a MPEG system include elementary streams (the raw audio, data or video media), program streams (a group of elementary streams that make up a program) and transport streams that carry multiple programs.

**Basic Operation of an MPEG system:** The MPEG system allow multiple media types to be used (voice, audio and data), codes and compresses each media type, adds timing information and combines (multiplexes) the media channels into a MPEG program stream. Multiple program streams (e.g. television programs) can be combined into a transport channel. When the MPEG signal is received, the program channels are separated (demultiplexed), individual media channels are decoded and decompressed and they are converted back into their original media form. The MPEG system has dramatically evolved since 1991 when it was introduced primarily for use on compact disk (CD) stored media.

### 12.5.1 MPEG Standards

The MPEG standards are an evolving set of standards for video and audio compression and for multimedia delivery developed by the Moving Picture Experts Group (MPEG).

**MPEG-1** was designed for coding progressive video at a transmission rate of about 1.5 million bits per second. It was designed specifically for Video-CD and CD-i media. MPEG-1 audio layer-3 (MP3) has also evolved from early MPEG work.

**MPEG-2** was designed for coding interlaced images at transmission rates above 4 million bits per second. MPEG-2 is used for digital TV broadcast and DVD. An MPEG-2 player can handle MPEG-1 data as well.

MPEG-1 and -2 define techniques for compressing digital video by factors varying from 25:1 to 50:1. The compression is achieved using five different compression techniques:

The use of a frequency-based transform called Discrete Cosine Transform (DCT). Quantization, a technique for losing selective information (sometimes known as lossy compression) that can be acceptably lost from visual information. Huffman coding, a technique of lossless compression that uses code tables based on statistics about the encoded data. Motion compensated predictive coding, in which the differences in what has changed between an image and its preceding image are calculated and only the differences are encoded. Bi-directional prediction, in which some images are predicted from the pictures immediately preceding and following the image. The first three techniques are also used in JPEG file compression.

A proposed MPEG-3 standard, intended for High Definition TV (HDTV), was merged with the MPEG-2 standard when it became apparent that the MPEG-2 standard met the HDTV requirements.

MPEG-4 is a much more ambitious standard and addresses speech and video synthesis, fractal geometry, computer visualization, and an artificial intelligence (AI) approach to reconstructing images. MPEG-4 addresses a standard way for authors to create and define the media objects in a multimedia presentation, how these can be synchronized and related to each other in transmission, and how users are to be able to interact with the media objects.

MPEG-21 provides a larger, architectural framework for the creation and delivery of multimedia. It defines seven key elements:

- Digital item declaration
- Digital item identification and declaration
- Content handling and usage
- Intellectual property management and protection
- Terminals and networks
- Content representation
- Event reporting

The details of various parts of the MPEG-21 framework are in various draft stages.

The Figure 12.1 shows how the video coding developed for MPEG-4 was a joint effort between the ISO/IEC and United Nations ITU. Both groups worked together to produce the video coding standard. The ISO/IEC version is called advanced video coding (AVC) and the ITU version is called H.264.

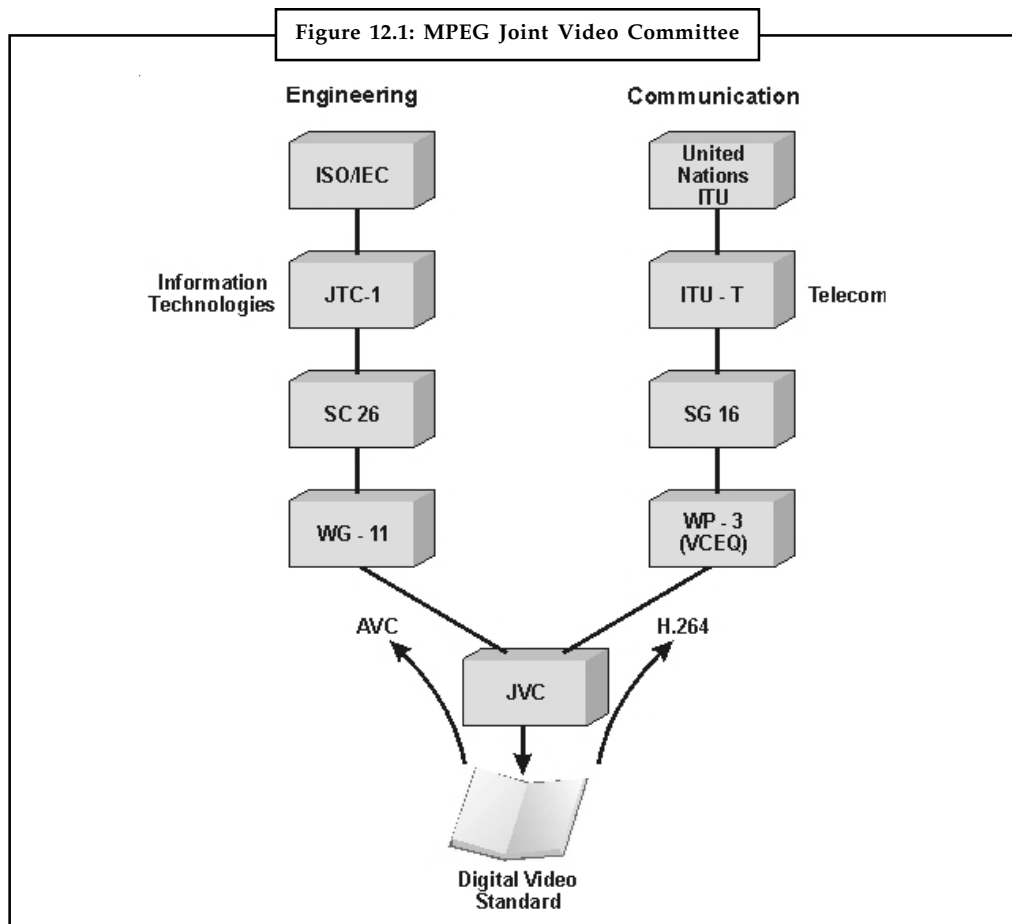

Source: [http://www.althos.com/sample\\_diagrams/ag\\_MPEG\\_JVC\\_low\\_res.jpg](http://www.althos.com/sample_diagrams/ag_MPEG_JVC_low_res.jpg)

There are other MPEG industry standards including MPEG-7, which adds descriptions to multimedia objects and MPEG-21, which adds rights management capability to MPEG systems.

## Notes

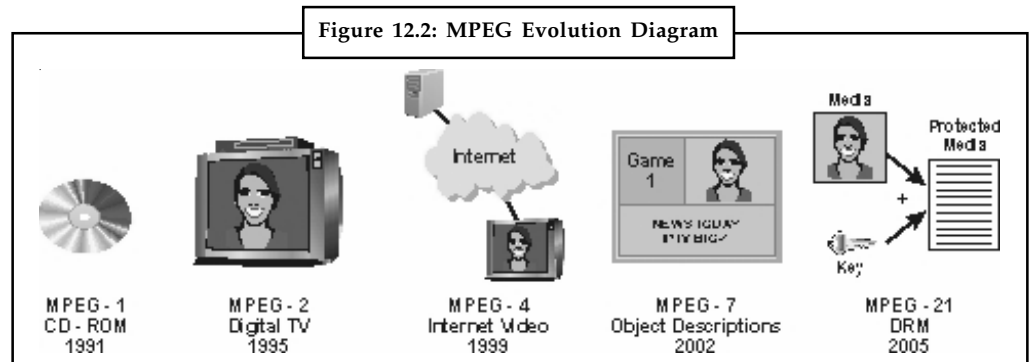

Source: [http://www.althos.com/sample\\_diagrams/ag\\_MPEG\\_Evolution\\_low\\_res.jpg](http://www.althos.com/sample_diagrams/ag_MPEG_Evolution_low_res.jpg)

This figure shows how MPEG systems have evolved over time. This diagram shows that the original MPEG specification (MPEG-1) developed in 1991 offered medium quality digital video and audio at up to 1.2 Mbps, primarily sent via CD ROMs. This standard evolved in 1995 to become MPEG-2, which was used for satellite and cable digital television along with DVD distribution. The MPEG specification then evolved into MPEG-4 in 1999 to permit multimedia distribution through the Internet. This example shows that work continues with MPEG-7 for object based multimedia and MPEG-21 for digital rights management.



*Did u know?* The MPEG was established in 1988 by the initiative of Hiroshi Yasuda (Nippon Telegraph and Telephone) and Leonardo Chiariglione.

## 12.6 Fractal Image Compression

The standard methods of image compression come in several varieties. The current most popular method relies on eliminating high frequency components of the signal by storing only the low frequency components (Discrete Cosine Transform Algorithm). This method is used on JPEG (still images), MPEG (motion video images), H.261 (Video Telephony on ISDN lines), and H.263 (Video Telephony on PSTN lines) compression algorithms.

The most widely known practical fractal compression algorithm was invented by Barnsley and Alan Sloan. Fractal Compression was first promoted by M. Barnsley, who founded a company based on fractal image compression technology but who has not released details of his scheme. The first public scheme was due to E. Jacobs and R. Boss of the Naval Ocean Systems Centre in San Diego who used regular partitioning and classification of curve segments in order to compress random fractal curves (such as political boundaries) in to Literature Number: BPRA065 two dimensions [BJ], [JB]. A doctoral student of Barnsley's, A. Jacquin, was the first to publish a similar fractal image compression scheme [J].

### 12.6.1 What is Fractal Image Compression

Imagine a special type of photocopying machine that reduces the image to be copied by half and reproduces it three times on the copy (see Figure 12.3). What happens when we feed the output of this machine back as input? Figure 12.3 shows several iterations of this process on several input images. We can observe that all the copies seem to converge to the same final image. Since the copying machine reduces the input image, any initial image placed on the copying machine will be reduced to a point as we repeatedly run the machine; in fact, it is only the position and the orientation of the copies that determines what the final image looks like.

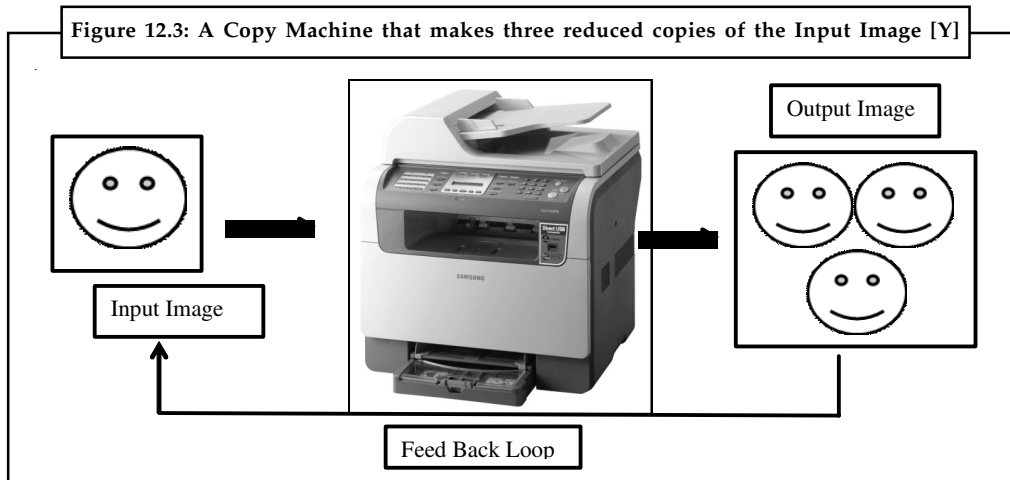

Source: <http://www.extralast.com/pics/CLX-3160FN.jpg>

The way the input image is transformed determines the final result when running the copy machine in a feedback loop. However, we must constrain these transformations, with the limitation that the transformations must be contractive (see contractive box), that is, a given transformation applied to any two points in the input image must bring them closer in the copy. This technical condition is quite logical, since if points in the copy were spread out the final image would have to be of infinite size. Except for this condition the transformation can have any form.

In practice, choosing transformations of the form is sufficient to generate interesting transformations called affine transformations of the plane. Each can skew, stretch, rotate, scale and translate an input image.

A common feature of these transformations that run in a loop back mode is that for a given initial image each image is formed from a transformed (and reduced) copies of itself, and hence it must have detail at every scale. That is, the images are fractals. This method of generating fractals is due to John Hutchinson [H], and more information about the various ways of generating such fractals can be found in books by Barnsley [B] and Peitgen, Saupe, and Jurgens [P1, P2].

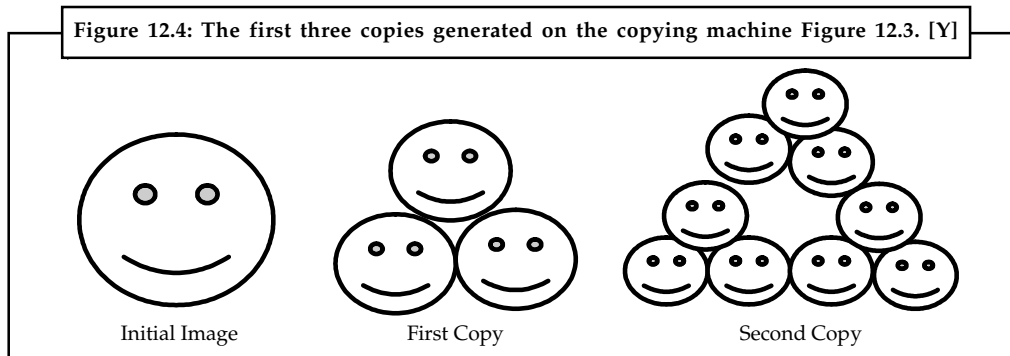

### Self Assessment

State whether the following statements are true or false:

6. The most common image file formats supported by JPEG are JPEG/Exif and JPEG/JFIF.
7. A disadvantage of lossy compression is that if a user repeatedly compress and decompress an image, the image loses a little more quality each time.

Notes

8. MPEG is not part of International Standards Organization (ISO).
9. DCT stands for Discrete Cosine Transform.
10. The fractal compression algorithm was invented by Alan Sloan.



Case Study

## The Humble GIF

### **The Birth of the GIF**

In 1987, CompuServe released the GIF format for graphics, as a free and open specification. In other words, any Web developer or graphics creator was free to create, post, trade, fold, spindle, and mutilate GIFs as they saw fit. The creators used the LZW (Lempel Ziv Welch) method of data compression to reduce the size of the files, and herein lies the copyright issue. Note that the LZW compression method is also used in TIFF graphics and several older file compression utilities, but because relatively few people use either TIFF graphics or these older file compression programs, I will focus on the usage of GIFs.

The LZW was described by Terry A. Welch in the June 1984 issue of IEEE's Computer magazine. Unisys held, and still holds a patent, but describing the algorithm made no mention of this. Welch, a Sperry employee, extended the work of previous developers Lempel and Ziv. Sperry Corporation was granted the U.S. patent in 1985. Sperry and Burroughs merged in 1986 to form Unisys, thus Unisys became the owner of the Sperry patents. CompuServe saw no reason to place any restrictions on GIF usage, and GIF graphics quickly became a staple of the World Wide Web. They were relatively easy to create, relatively compact, and quite flexible.

Unfortunately, the issue of patent infringement came up almost immediately. Although Unisys did not enforce their copyright for many years, the idea of the format having copyright issues at all was a cause for concern. Some CompuServe users immediately removed all the GIFs on their sites, or converted their graphics to JPEG or other formats that were not covered by the Unisys patents. Many other Web designers continued to use GIFs with little concern for the legalities, or were ignorant of the entire question. CompuServe quickly backed off of the issue. They claimed that they would have nothing to do with the debate, and any legal arguments were between Unisys and third parties. Interestingly, Unisys's original patent is due to expire in 2003; no word yet as to whether Unisys intends to extend their patent.

### **Unisys Enforces its Copyright**

Unisys did not begin to enforce its copyright until December 1994, when it announced that, as it owned the compression method used to make GIFs, any Websites that used GIFs not produced by Unisys-licensed software must pay the company a staggering \$5,000. Unisys required:

"[a] one-time payment of \$5,000.00 U.S. for each license agreement (limited to two servers at each licensed Website), or [sic] a single payment of \$7,500 U.S. for a license for both Billboard and Intranet."

The idea came under fire immediately. According to the outraged owners of BurnAllGifs, an organization opposed to Unisys's assertion of control over the GIF format:

*Contd....*

## Notes

"The fact that Unisys was able to patent LZW is due to a flaw in the US patent system that makes even pencil-and-paper calculations patentable. You could violate some US patents just doing the story problems in a math or computer science textbook!"

When Unisys first announced that it would begin to enforce its copyright claims, they stated that they had no interest in pursuing patent infringement claims on anyone using GIFs for non-profit or personal uses, or against freeware developers who created GIF-making utilities. However, in September 1999, they issued a "clarification" that stated anyone using GIFs was subject to a patent infringement claim from Unisys if they used GIFs on any Internet or intranet site. You can imagine the furor that particular claim has caused. There's a strong movement on the Web that advocates the abandonment of the GIF entirely in defiance of Unisys's claims, but as we well know, GIFs are still the graphic of choice for many Web designers.

### The Fate of the Humble GIF

Where that leaves today's GIF users is not completely clear. While legal opinion varies, most lawyers involved in the issue seriously doubt that GIF users, such as myself and SitePoint, are in any danger of breaking any patent law – only the makers of graphics utilities that are capable of creating GIFs are responsible for any copyright or licensure fees. The best guess seems to be that if you are using GIFs created by licensed programs (and most of the big boys like Paint Shop Pro, Illustrator, etc. have long since paid their fees to Unisys), you are OK. If you maintain a personal or non-profit Website, you might technically be in violation, but Unisys is not going to bother you. However, if you are using GIFs on your for-profit page, or you are a software developer who markets a GIF creation program without a license from Unisys, you might get contacted one of these fine days.

### Questions:

1. Discuss the importance of GIF format in multimedia.
2. Critically analyse the case study with examples from real life.

*Source:* Written by Michael Tuck on <http://www.sitepoint.com/case-study-humble-gif/>

## 12.7 Summary

- Raster formats can be generally separated into two categories. Lossy formats lose resolution (sharpness) when converted to, while lossless formats preserve image information.
- Raster image formats store images as bitmaps (also called "pixmap").
- Many older graphical user interfaces used bitmaps in their built-in graphics subsystems.
- The original version of GIF was 87a (or GIF87a ). In 1989, CompuServe devised an enhanced version, called 89a.
- The interlacing feature in a GIF file creates the illusion of faster loading graphics.
- GIF (89a) allows transparent pixels.
- Owing to the general restriction on the number of available colours in a single GIF image to 256 the GIF format is unsuited to large colour photographs
- The images stored in a JPEG format could have one of the following file extensions: .JPG, .JPEG, .JFIF, .JIF .or .JPE.
- Fractal Compression was first promoted by M. Barnsley, who founded a company based on fractal image compression technology.

Notes

### 12.8 Keywords

**GIF (89a):** The only widely used image format to support animation, unless you want to use FLASH or other vector-based animation formats.

**Image Compression:** A process intended to yield a compact representation of an image, thereby reducing the image storage/transmission requirements.

**JPEG Standard:** Refers to both the technique for compressing an image into a stream of bytes and then decompressing it back close to its original form, and the file format holding that stream.

**MIME Media:** Multipurpose Internet Mail Extensions (MIME) is an Internet standard that extends the format of email to support text in character sets other than ASCII, non-text attachments, message bodies with multiple parts Header information in non-ASCII character sets.

**Progressive JPEG:** An image created using the JPEG suite of compression algorithms that will “fade in” in successive waves of lines until the entire image has completely arrived.

### 12.9 Review Questions

1. Write a brief note on classification of image formats.
2. Explain why do people have to be aware of different image formats.
3. Describe pixel format in detail.
4. What is image compression? Why is it important in multimedia?
5. Graphics Interchange Format is an image format. Discuss.
6. What is Fractal Image Compression? Explain in detail.
7. Why do people use Graphics Interchange Format?
8. Write a note on MPEG standards.
9. Why should people use JPEG? How is it different from GIF?
10. Give a detailed history of MPEG.

### **Answers: Self Assessment**

- |          |           |
|----------|-----------|
| 1. False | 2. True   |
| 3. False | 4. True   |
| 5. True  | 6. True   |
| 7. True  | 8. False  |
| 9. True  | 10. False |

### 12.10 Further Readings



Books

Frederick P. Brooks, Jr., Kenan Professor of Computer Science, *The Mythical Man-Month: Essays in Software Engineering*, University of North Carolina at Chapel Hill.



K. Andleigh and K. Thakkar, *Multimedia System Design*, PHI, PTR.

Notes

Ling Guan, S. Y. Kung, Yifeng He, *Multimedia Image and Video Processing*

Steve Rimmer (2000), *Advanced Multimedia Programming*, MHI.

Tay Vaughan, *Multimedia Making it work*, Seventh Edition, Tata McGraw-Hill Education Private Ltd.



Online links

<http://developer.android.com/reference/android/graphics/ImageFormat.html>

<http://nora.lis.uiuc.edu:3030/companion/view?docId=blackwell/9781405103213/9781405103213.xml&doc.view=print&chunk.id=ss1-2-10&toc.depth=1&toc.id=0>

[http://snook.ca/archives/design/which\\_image\\_for](http://snook.ca/archives/design/which_image_for)

[http://users.mct.open.ac.uk/yr258/papers/Rogers\\_Scaife98.pdf](http://users.mct.open.ac.uk/yr258/papers/Rogers_Scaife98.pdf)

<http://www.icheg.org/icheg-game-history/timeline/>

<http://www.ict.griffith.edu.au/teaching/1611ICT/mm1lectures/111/Writing%20For%20Multimedia%20Great%20Moments%20In%20Multimedia%20History.htm>

<http://www.imagemagick.org/script/formats.php>

## Unit 13: Multimedia Tools for WWW

### CONTENTS

Objectives

Introduction

13.1 Multimedia Tools in the Information Commons

13.1.1 Audio

13.1.2 Video

13.1.3 Photo

13.1.4 Text Scanning and OCR

13.2 Font Editing and Design Tools

13.3 Text Editing and Word Processing Tool

13.4 Image Editing Tool

13.5 Painting and Drawing Tools

13.6 Sound Editing Tool

13.6.1 Digitized Audio

13.6.2 MIDI

13.6.3 Comparison between MIDI and Digitized Audio

13.6.4 Advantages and Disadvantages of Digitized Audio and MIDI

13.7 Animation, Video and Digital Movie Tool

13.7.1 Video Formats

13.8 Summary

13.9 Keywords

13.10 Review Questions

13.11 Further Readings

### Objectives

After studying this unit, you will be able to:

- Explain the multimedia tools in the information commons
- Describe the font editing and design tools
- Explain the text editing and word processing tools
- Describe the image-editing tools
- Understand the painting and drawing tools
- Describe the sound editing tools
- Explain the animation, video and digital movie tools

## **Introduction**

Notes

Since the advent of the Internet, the computing and communications industry has progressed very rapidly. Today, any user with a desktop computer can access and share multimedia documents with others through the Internet. It seems certain that in the near future every person, no matter where located geographically, will be equipped with some sort of network computing capability, either by means of conventional desktop computing or through information appliances. This not only means that geographically distributed people will be able to easily communicate, but also “collaborate”; i.e., share multimedia documents and applications. Examples are joint editing, white boarding, joint browsing, and multi-user presentations, used in a variety of applications such as conferencing, collaborative design, training and tele-learning.

### **13.1 Multimedia Tools in the Information Commons**

There are multiple tools that are available for the creation, recording, editing, and transfer of multimedia. Some of the tools for multimedia are: Audio, video, photos, text scanning and OCR.

#### **13.1.1 Audio**

Audio is music, speech, or any other sound that the computer converts from analog sound/waves into a digital format. Sound helps in providing an additional element. There are times when it is important to let users hear the actual sound or sounds from a person or event. There are various applications which are used to edit the audio, export and import to audio files to different locations. Some of the editing and recording software application tools are as follows:

##### **Audacity**

Audacity is a free audio editor. With the use of this application one can record and edit audio, import and export many types of audio. It can mix multiple tracks and create one or more audio files. Audacity can be used to edit and cleanup tracks, mix tracks together, or apply effects to recordings.

##### **Wave Studio (aka “Creative Wave Studio”)**

This application can be used to record and edit your sound files. You have the ability to select from CD., line input (a tape player) and a microphone input, mix them all together and record the mix as a .wav file.

##### **WHAM: (Waveform Hold and Modify)**

A simple audio editing application which supports a number of audio formats. WHAM also allows you to convert from one audio format to another. It is able to read a number of different audio format files (such as .au, .aiff, and .wav) and save to these formats as well. Limited to 8-bit.

##### **Goldwave**

Another good audio converting and editing application. Goldwave also allows you to “re-sample” an audio file which WHAM cannot do. Not limited to 8-bit. it can do 16-bit as well. Multimedia power is used for new ways of having fun. The idea is to use computers as a medium for entertainment. With the addition of computer games to the multimedia revolution, entertainment has reached new heights. Multimedia is also great for artistic expression.

Notes

### 13.1.2 Video

Video is made up of series of frames of slightly varied images which, when shown in rapid succession give the impression of movement. Shooting video requires video skills and an understanding of the special demands of multimedia and pictures. Video sequences are made by capturing frames. Some of the commonly used video capturing and editing applications are as follows:

#### Adobe Premiere

A very powerful video capturing and editing application. Adobe premiere allows for two tracks of video with a number of different transitions available from one to the other. Multiple audio tracks are also possible. Premiere can output in either quick time or avi formats.

#### Adobe After Effects

Adobe After Effects 5.0 enables you to create motion graphics and visual effects for professional cross-media delivery. It is a complete tool set for 2-D and 3-D compositing, animation, and effects for film, video, multimedia, and the Web, and offers tight integration with Adobe Premiere, Adobe Photoshop, and Adobe Illustrator.

### 13.1.3 Photo

Images whether represented analog or digital plays a vital role in a multimedia. It is expressed in the form of still picture, painting or a photograph taken through a digital camera. Digital photo and printed photo both can be imported and exported. They can be edited for slideshows, presentations, print ready format. Photos can be imported by using direct camera connection or Removable media such as Compact Flash, Memory Stick, Secure Digital/Multimedia Card and Smart Media. Some of the common photo editing software tools used are:

#### Adobe Photoshop CS (Windows/Mac)

Photoshop may be the industry leader when it comes to photo editing and graphic design. Photoshop is a pixel editing program. It is primarily used to modify digital images although it also has vector capabilities.

#### iPhoto (Mac)

Apple's iPhoto photo editing software for iMac ships free with every Mac as a part of the iLife suite. Sort of a Picasa on steroids, iPhoto may function primarily as a photo organization and easy to use photo editing tool, but it also offers users loads of neat perks, among them:

- Instant sharing on Facebook, Flickr and more without leaving iPhoto
- Create slideshows
- Put together photo books, calendars, and letterpress cards and order prints right from iPhoto
- Email themes, making your photos look cool when you mail them
- Apple-wide integration, meaning you can sync photos to your iPad, iPhone, iPod, or to Apple TV for viewing on widescreen HD TVs.

### 13.1.4 Text Scanning and OCR

Notes

Optical Character Recognition is a computer program that works with a scanner. It converts the scanned page to a text file. The text must be typeset (books, magazines, newspapers), manually typed (a machine we used to use before PC's and laser printers) or computer printed. OCR doesn't work with hand-written pages.

Text Scanning in conjunction with OCR is the process of optical rasterization of a printed document by using a scanner or a digital camera. The document will be divided into image points and each point will be assigned a value describing black and white, grayscale or color information. OCR in simple words is trying to have printed text transcribed by a computer. The text convert can be save and edit the text in a variety of formats.



*Did u know?* Rasterization is the process of determining the appropriate pixels for representing picture or graphics object is known as rasterization.

## 13.2 Font Editing and Design Tools

There are many software applications to create customized font. These applications or tools help an multimedia developer to converse his idea or the realistic feeling. Using these software different typefaces can be created. In some multimedia projects it may be required to create special characters. The font editing tools is used to possibly create a special symbols and use it in the entire text. Following is the list of software that can be used for editing and creating fonts:

- Fontographer
- Fontmonger
- Cool 3D text

There are many special font editing tools that can be used to make your own font type so you can communicate an idea or graphic feeling exactly. With these tools professional typographers create different text and display faces.

1. **Fontographer:** Fontographer is a specialized graphics editor. It is compatible with both Macintosh and Windows platforms. It can be used to develop PostScript, TrueType, and Open Type fonts. It can also modify existing typefaces and incorporate PostScript artwork.
2. **Fontmonger:** A simple font editing tool, used mainly as a conversion utility between Type 1 and TrueType.
3. **Cool 3D text:** Using this software you can create three-dimensional graphics and animations.

**Making Pretty Text:** For making the text appear pretty all that is needed is a toolbox which is full of fonts and special graphics applications that can add effects, stretch, shrink, shade, color and anti-alias your words into real artwork. Pretty text can be found in bitmapped drawings where characters have been tweaked, manipulated and blended into a graphic image.

**Hypermedia and Hypertext:** *Multimedia* is the field concerned with the computer-controlled integration of text, graphics, drawings, still and moving images (Video), animation, audio, and any other media where every type of information can be represented, stored, transmitted and processed digitally. Hypermedia is not constrained to be text-based. It can include other media, e.g., graphics, images, and especially the continuous media – sound and video. When text is stored in a computer instead of on printed pages the computer's powerful processing capabilities can be applied to make the text more accessible and meaningful. This text can be called as hypertext. Hypertext is a text which contains links to other texts. The term was invented by Ted

**Notes**

Nelson around 1965. Hypertext is therefore usually non-linear. Words can be made into buttons that will take you to cross-reference in a program. Hypertext capabilities can be used to link graphics, some animation and of course other text. The help system of windows is an example of hypertext. Hypertext systems are useful when presenting and referencing large amounts of textual information. Some hypertext authoring programs provide graphical links for animation, sound and video as well as text.

**Hypermedia Structures:** Hypermedia is a style of building systems for organising, structuring and accessing information around a network of multimedia nodes connected together by links. The general structure of hypermedia allowed hypermedia to be applied to a wide variety of task domains.

- **Links:** Links are connections between conceptual elements. Links are the navigation pathways and menus.
- **Nodes:** Nodes are accessible topics, documents, messages, and content elements. Nodes and links form the backbone of a knowledge access system.
- **Anchors:** An anchor is defined as the reference from one document to another document, image, sound, or file on the Web. The source node linked to the anchor is referred to as a link anchor. The destination node linked to the anchor is referred to as a link end.
- **Navigating Hypermedia Structures:** The simplest way to navigate hypermedia structures is via buttons. Location markers must be provided to make navigation user-friendly.

**Searching for Words:** The typical methods for word searching in hypermedia systems are as follows:

- Categorical search (movies, jobs, sports, weather)
- Word relationship
- Automatically compute statistical probabilities based on semantic distance of words or phrases relative to the context of the pages they are embedded on and other similar pages
- Adjacency (within, not within, preceded by, within doc)
- Alternates (or)
- Association (and) Negation
- Truncation (patriot\* = patriot, patriots, patriotic...)
- Intermediate words - [Mark Bealo] vs "Mark Bealo"
- Frequency



*Task* Create three dimensional graphics using the Design tool.

### 13.3 Text Editing and Word Processing Tool

The word processors are powerful applications that are used for creating text by the most computer users. It includes spell checkers, table formatters, thesaurus, and pre-built templates for commonly used documents. This tool is used for creating project letters, invoices, and storyboards. The software allows embedded multimedia elements. Microsoft Word and Word Perfect are the examples of the word processors.

The word processors often comes bundled in an "Office Suite."

## Optical Character Recognition (OCR) software

Notes

The OCR software converts bitmapped characters into electronically recognizable ASCII text. It makes use of probability and expert system algorithms. It is very accurate and saves time and effort.



*Did u know?* TextPad is an award winning *text editor* for Windows XP.

## 13.4 Image Editing Tool

Image Editing tools are the tools that are used to edit existing bitmap images and pictures. They are similar to painting and drawing tools as they can also create images from scratch. It is also capable of converting the image data type file format. It is used usually for reinventing and recreating the image. The common Image process software are Adobe Photoshop and Paint Shop pro.

The basic features of image editing tool include:

- Conversion of image-data types and file formats
- Masking features
- Colour-mapping controls for precise adjustment of colour balance.
- Employment of virtual memory scheme
- Ability to re-sample and resize an image.
- Support third-party plugins
- Multiple Tools for retouching, blurring, sharpening, lightening, darkening, smudging, and tinting.
- Multiple typefaces, styles, sizes, and type manipulation and masking routines.



*Notes* Many image file formats use data compression to reduce file size and save storage space. Digital compression of images may take place in the camera, or can be done in the computer with the image editor. When images are stored in JPEG format, compression has already taken place.

## Self Assessment

Fill in the blanks:

1. ....are specialized and powerful tools for enhancing and retouching existing bitmapped images.
2. .... can output in either quick time or avi formats.
3. Photoshop is a ..... program.
4. .... converts the scanned page to a text file.
5. .... can be used to develop PostScript, TrueType, and Open Type fonts.

Notes

- 6. .... systems are useful when presenting and referencing large amounts of textual information.
- 7. .... are accessible topics, documents, messages, and content elements.

### **13.5 Painting and Drawing Tools**

Most graphic programs use bitmapped images since they provide the greatest choice. It includes the Eyedropper tool, Autotrace tool, and anti-aliasing, airbrushing, blending, and masking functionalities. Painting and drawing tools generally come with a graphical user interface with pull down menus for quick selection. It can be used to create almost all kinds of possible shapes and resize them. The Drawing file can be imported or exported in many image formats like .gif, .tif, .jpg, .bmp, tec.

Few examples of Painting software are: PhotoShop, Fireworks, and Painter

Few examples of good drawing software are: "Corel Draw", FreeHand, and Illustrator

Some of the features of the painting and drawing tools are as follows:

- An intuitive graphical user interface.
- Scalable dimensions.
- Multiple undo capability.
- Scalable text font support.
- Support for third-party special effect plugins.
- Layering capability.
- Ability to paint with patterns and clip art.
- Option of Zooming, for magnified pixel editing.

### **13.6 Sound Editing Tool**

This tool allows the user to see music as well as hear sound. This is done by drawing a representation of sound in fine increments. Sound editing tools enables the user to create custom system beeps. System beeps are pre-packaged sounds that indicate an error, warning or special user activity. Sound can be cut/copy and paste, edited with great accuracy. Sound can be integrated into your multimedia project very easily by using sound editing tools. A good sound editing software is "Cool Edit" and "Sound Forge".



*Task* Record sound using Sound Recorder software available in Windows and check for the file type supported by Sound Recorder.

#### **13.6.1 Digitized Audio**

Digital audio is created when a sound wave is converted into numbers ± a process referred to as digitizing. It is possible to digitize sound from a microphone, a synthesizer, existing tape recordings, live radio and television broadcasts, and popular CDs. You can digitize sounds from a natural source or pre recorded. Digitized sound is sampled sound. Every nth fraction of a second, a sample of sound is taken and stored as digital information in bits and bytes. The quality of this digital recording depends upon how often the samples are taken.



There are two main types of digitized audio files on a computer. PCM stands for Pulse Code Modulation. In this technique each number in the digitized audio file represents exactly one sample in the waveform. Common examples of PCM files are WAV files, AIFF files, and Sound Designer II files. Audacity supports WAV, AIFF, and many other PCM files.

The other type is compressed files. Earlier files used logarithmic encodings to compress more dynamic range out of fewer bits for each sample, like the u-law or a-law encoding in the Sun AU format. Modern compressed audio files use sophisticated psychoacoustics algorithms to represent the essential frequencies of the audio signal in far less space. Examples include MP3 (MPEG I, layer 3), Ogg Vorbis, and WMA (Windows Media Audio).

### 13.6.2 MIDI

Musical Instrument Digital Interface (MIDI) is the interface between electronic musical instruments and computers is a small piece of equipment that plugs directly into the computer's serial port and allows the transmission of music signal. MIDI is considered to be the most compact interface that allows full-scale output. MIDI file is used to collect and store the messages and the timing information in a computer file system, which is commonly called a MIDI file, or more formally, a Standard MIDI File (SMF). MIDI files are typically created using MIDI sequencers. A simple MIDI system is shown in Figure 13.1 given below:

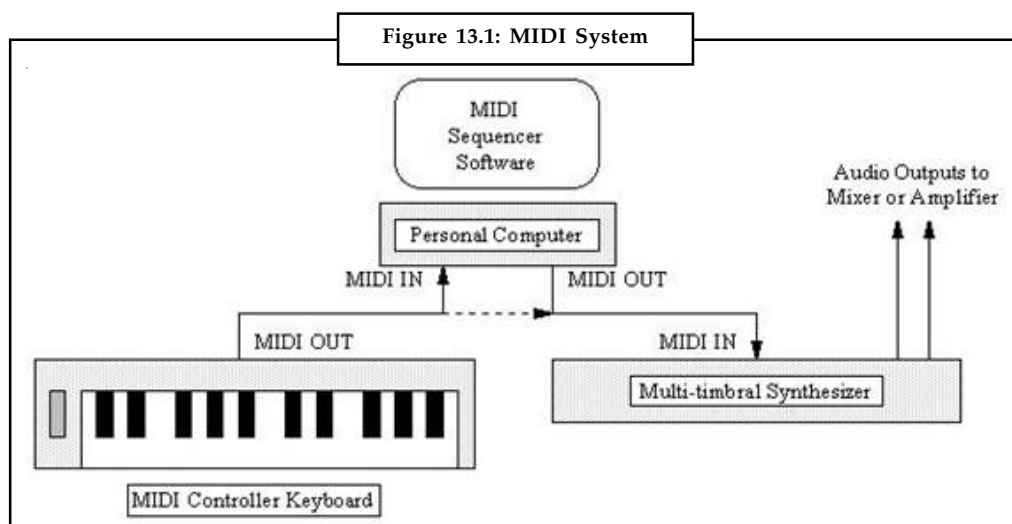

Source: [http://www.hiphopjazzproduction.com/hiphopimages/clip\\_image002.jpg](http://www.hiphopjazzproduction.com/hiphopimages/clip_image002.jpg)

A MIDI interface has two different components:

1. **Hardware** connects the equipment. It specifies the physical connection between musical instruments, stimulate that a port MIDI port is built into an instrument, specifies a MIDI cable and deals with electronic signals t that are sent over the cable.
2. **Data format** encodes the information traveling through the hardware MIDI data format includes an instrument-connected data format. The encoding includes, besides the instrument specification, the notion of the beginning and end of a note, basic frequency and sound volume; MIDI data allow an encoding of about 10 octaves, which corresponds to 128 notes.

### 13.6.3 Comparison between MIDI and Digitized Audio

1. MIDI is analogous to structured or vector graphics, while digitized audio is analogous to bitmapped images.

**Notes**

2. MIDI is device dependent while digitized audio is device independent.
3. MIDI files are much smaller than digitized audio files.
4. MIDI files sound better than digital audio files when played on a high-quality MIDI device.
5. MIDI files size is 200 to 1000 times smaller than Digitized Audio.
6. MIDI files are easily editable and all the information retainable, while Digitized audio are difficult to edit.
7. MIDI files requires less storage space but Digitized audio requires large storage space.



*Did u know?* The method for digitally encoding the high quality stereo of the consumer CD music market is an instrument standard, ISO 10149. This is also called as RED BOOK standard.

### 13.6.4 Advantages and Disadvantages of Digitized Audio and MIDI

Both the file formats have their own advantages as well as disadvantages. Discussed first the advantages of MIDI over digitized audio:

1. MIDI files are much smaller than digitized audio files, and the size of MIDI file is completely independent of playback quality. Broadly, MIDI files will be 200 to 1000 times smaller than CD-quality digitized audio files. As MIDI files are small, they don't take up as much RAM, disk space, and CPU resources.
2. In some cases, MIDI files may sound better than digital audio files if the MIDI sound source you are using is of high quality.
3. You can change the length of a MIDI file (by varying its tempo) without changing the pitch of the music or degrading the audio quality.

Now for the disadvantages:

1. Because MIDI data isn't sound, you can be certain that playback will be accurate only if the MIDI playback device is identical to the device used for production.
2. MIDI cannot easily be used to play back spoken dialog. There are two additional and often more compelling reasons to work with digital audio:
  - ❖ A wider selection of application software and system support for digital audio is available for both the Macintosh and Windows platforms.
  - ❖ The preparation and programming required for creating digital audio do not demand knowledge of music theory; working with MIDI data usually requires an ounce of acquaintance with musical scores as well as audio production.

There are many applications of Digital Audio and Midi being used together:

- Modern Recording Studio — Hard Disk Recording and MIDI
- Analog Sounds (Live Vocals, Guitar, Sax etc.) — DISK
- Keyboards, Drums, Samples, Loops Effects —MIDI
- Sound Generators: use a mix of
- Synthesis

- Samples
- Samplers — Digitize (Sample) Sound then
- Playback
- Loop (beats)
- Simulate Musical Instruments



*Notes* While MIDI is a music format for computers, it is NOT possible to simply burn a collection of MIDI files onto a CD-R disc and then play them in your CD player.

## 13.7 Animation, Video and Digital Movie Tool

Animation is a sequence of bitmapped graphic scenes or frames, rapidly played back. Animations can be made within some authoring systems by moving objects or sprites to simulate motion. Movie-making tools takes advantage of QuickTime and AVI formats to create, edit, and present digitized motion video segments. Digital video editing and playback require a large amount of free disk space. At the time of working with digital video, it is necessary to defragment and optimize the disk before recording and playing back movie files. It is necessary to compress movie files before delivery. The compression ratio is the size of the original image divided by the size of the compressed image. Compression can be lossy or lossless. Lossy schemes ignore picture information the viewer may not miss. Lossless schemes preserve the original data precisely.

### 13.7.1 Video Formats

Video files are collections of images, audio and other data. The attributes of the video signal include the pixel dimensions, frame rate, audio channels, and more. In addition, there are many different ways to encode and save video data.

Video files are significantly more complex than still image files. Not only is there a lot more different kinds of information inside them, but the structure of a video file is much more “mix-and-match”. One can tell a lot about most still image files by the file extension, but that does not hold for video. The file type (such as .MOV) is just a container, and could be filled with really low quality web video, or it might have ultra-high-quality 3-D video and five channels of theater-quality audio.

All file formats are structures for bundling up some type of data. And nearly every computer file has more than one type of data inside the file. Video files are particularly complex internally, but they all need to be stored in one of the basic container types. Within a particular container type, such as Quicktime or AVI, there can be a vast difference between the video signal attributes, the codecs used, and the compression.

### Quick Time

Quick Time is a software-based architecture for integrating sound, text, animation, and video on Macintosh and Windows platform. It is an extensible system for multimedia delivery. This software can deliver 3-D animations, virtual reality, and streaming audio-video on the Web. The three QuickTime elements are Movie file format, Media Abstraction Layer, and Media services. Quick Time includes built-in support for ten different media types. It offers a

**Notes**

comprehensive set of services and allows embedded commands in HTML documents. Quicktime files can be recognized by their file name extensions: qt, mov, and moov.

**Audio Video Interleaved (AVI)**

Audio Video Interleaved is a Microsoft-developed format for playing full-motion interleaved video and audio sequences in Windows. It does not require specialized hardware. It is an inextensible, open environment. AVI lacks serious video editing features. The Open DML format was developed to make AVI more functional.

QuickTime and Audio Video Interleaved (AVI) formats support special algorithms, provide a methodology for interleaving, and allow organized streaming of data from disk into memory.



*Notes* QuickTime 7 Pro can convert your media to different formats, so you can watch a movie or video on your iPhone, iPod, and Apple TV. You can also use QuickTime 7 Pro to record video and share everything you make with friends and family.

**Self Assessment**

State whether the following statements are true or false:

- 8. Coral Draw is a good example of Painting software.
- 9. MIDI use a sequence of frames in a specified order.
- 10. Painting software 'Photoshop' is dedicated to producing crafted bitmap images.
- 11. MIDI files are much smaller than digitized audio files.
- 12. Digital video editing and playback require a large amount of free disk space.
- 13. AVI is an extensible system for multimedia delivery.



*Case Study*

**Developing a Multimedia Tool for Increased International Science Collaboration**

**I**n 1998, the International Space Station brought together scientists from 16 countries to solve crucial problems in various areas of science. Many of the project's scientists did not speak the same language, which created a collaborative hurdle.

Under a CRDF Global grant, Russian scientists with experience in the design and construction of nuclear weapons are working with U.S. company Arkmedia to create a SNAPSE™ multimedia software toolset that will provide a multi-lingual collaborative environment. This technology will not only facilitate motion picture, still photo and audio usage, but will also support education, sharing of cultural resources, media object licensing, media management, communication and entertainment.

A team of ten Russian scientists, headed by Yury Alexandrovich Bukhshtab of the Keldysh Institute of Applied Mathematics and J. Johnson of Arkmedia, plans to develop a pilot version of this web-based toolset and deploy it on Russian Archives Online. The technology

*Contd....*

will be distributed to end-users globally for free, relying on sponsors and media object licensing commission fees to generate revenue. The project is currently in development with plans for completion in early 2007.

**Questions:**

1. Describe the basic Multimedia tools.
2. Explain the purpose of the multimedia tools.

Notes

*Source:* <http://www.crdglobal.org/news-and-events/success-stories/2011/06/30/developing-a-multimedia-tool-for-increased-international-science-collaboration>

### 13.8 Summary

- The multimedia building blocks such as text, audio, video, images, animation.
- The importance of text in multimedia.
- The font editing software which can be used for creating new fonts and the features of such software.
- Word processors and OCR software are used to handle text in multimedia.
- Painting and drawing tools, 3-D modeling tools, and image editing tools manipulate the graphical content of the project.
- QuickTime for Macintosh and AVI for Windows are the two most widely used video formats.

### 13.9 Keywords

**Audio:** Audio is music, speech, or any other sound that the computer converts from analog sound/waves into a digital format.

**Digitizing:** Digitizing refers to the conversion from analog signals to digital signals.

**Fontmonger:** A simple font editing tool, used mainly as a conversion utility between Type 1 and TrueType.

**Hypertext:** Hypertext is a text which contains links to other texts.

**Musical Instrument Digital Interface (MIDI):** Musical Instrument Digital Interface (MIDI) is the interface between electronic musical instruments and computers is a small piece of equipment that plugs directly into the computer's serial port and allows the transmission of music signal.

**Optical Character Recognition (OCR):** The OCR is the mechanical or electronic translation of scanned images of handwritten, typewritten or printed text into machine-encoded text.

**Video:** Video is made up of series of frames of slightly varied images which, when shown in rapid succession give the impression of movement.

**Word Processors:** Are powerful applications that include spell checkers, table formatters, thesaurus, and pre-built templates for commonly used documents.

### 13.10 Review Questions

1. Discuss about the text editing and word processing tool.
2. What are sound editing tools?

**Notes**

3. What are the features of Image Editing Tools?
4. Explain painting and drawing tools.
5. Define Hypermedia Structures and hypertext.
6. What are advantages and disadvantages of Digitized Audio and MIDI ?
7. Describe the animation, video and Digital Movie tools.
8. Describe in detail, Quick time for Windows and Macintosh.

**Answers: Self Assessment**

- |                       |              |
|-----------------------|--------------|
| 1. Image Editing Tool | 2. Premiere  |
| 3. pixel editing      | 4. OCR       |
| 5. Fontographer       | 6. Hypertext |
| 7. Nodes              | 8. False     |
| 9. False              | 10. True     |
| 11. True              | 12. True     |
| 13. False             |              |

**13.11 Further Readings**



*Books*

Frederick P. Brooks, Jr., Kenan Professor of Computer Science, *The Mythical Man-Month: Essays in Software Engineering*. University of North Carolina at Chapel Hill.

K. Andleigh and K. Thakkar, *Multimedia System Design*, PHI, PTR.

Steve Rimmer (2000), *Advanced Multimedia Programming*, MHI.

Tay Vaughan, *Multimedia Making it work*, Seventh Edition, Tata McGraw-Hill Education Private Ltd.



*Online links*

<http://nora.lis.uiuc.edu:3030/companion/view?docId=blackwell/9781405103213/9781405103213.xml&doc.view=print&chunk.id=ss1-2-10&toc.depth=1&toc.id=0>

[http://users.mct.open.ac.uk/yr258/papers/Rogers\\_Scaife98.pdf](http://users.mct.open.ac.uk/yr258/papers/Rogers_Scaife98.pdf)

<http://www.icheg.org/icheg-game-history/timeline/>

<http://www.ict.griffith.edu.au/teaching/1611ICT/mm1alectures/111/Writing%20For%20Multimedia%20Great%20Moments%20In%20Multimedia%20History.htm>

<http://www.learningtools.arts.ubc.ca/mloat.htm>

[http://www.mediabistro.com/10000words/7-essential-multimedia-tools-and-their\\_b376](http://www.mediabistro.com/10000words/7-essential-multimedia-tools-and-their_b376)

<http://www.slideshare.net/jmurdock3/multimedia-tools-for-educators>

## Unit 14: Designing for World Wide Web

Notes

### CONTENTS

Objectives

Introduction

14.1 Plug-ins

14.1.1 Purpose

14.1.2 Features of Plug-in

14.1.3 Most Useful Firefox Plug-ins for Web Developers

14.2 Text

14.2.1 Making Columns of Text

14.2.2 Flowing Text Around Images

14.3 Image

14.3.1 GIF and PNG Images

14.3.2 JPEG Images

14.3.3 Using Photoshop

14.3.4 Palettes

14.3.5 Interlaced and Progressive Scans

14.3.6 Transparency

14.4 Sound for the Web

14.5 Animation

14.5.1 Animation with JavaScript

14.5.2 User Control over GIF89a

14.5.3 Uses of Animation on Web

14.6 Summary

14.7 Keywords

14.8 Review Questions

14.9 Further Readings

### Objectives

After studying this unit, you will be able to:

- Explain the concept of plug-ins
- Discuss about text for Web
- Describe images for Web
- Understand the use of sound
- Describe animation for Web

## Introduction

The World Wide Web was not originally designed with multimedia in mind, but rather as a simple method for delivering text documents formatted in HTML, with occasional in-line graphic illustrations and figures.

### 14.1 Plug-ins

A plug-in is bits of computer code that is combined with a host application to perform specific functions. Common applications of plug-ins are used to enhance audio and video effects editing. **Plug-ins** add the power of multimedia to web browsers by allowing users to view and interact with new types of documents and images. **Helper applications**, or **players**, also provide multimedia power by displaying or running files downloaded from the Internet by your browser, but helpers are not seamlessly integrated into the operation of the browser itself. When an unrecognized embedded MIME-type that can't be displayed within your browser is called from an HTML document (sounds, movies, unusual text or image files), most browsers will automatically launch a helper application (if it is specified in the browser's preferences) to view or run it. However, this helper starts up and runs separately from the browser.

Many plug-ins are designed to perform special tasks not available without the plug-in installed. If you land on a web page containing embedded, compressed images, for example, and the proper plug-in to decompress those images is not installed, you will not be able to view the images.

Designers work around this problem by including hyperlinks in their pages, which direct the user to the site where the missing plug-in may be found. Users must then download and install the required plug-in, and then restart their browser. This is all a bit cumbersome. Until the market place determines which plug-ins will become de facto standards for the Web, however, developers have no alternative. Because downloading and installing plug-ins is perceived as a hassle for the end user, many tool developers use the Java and JavaScript capabilities already built into today's web browsers. To offer a plug-in's functionality to visitors at your own website, you may need the addition of MIME-type information to a special setup file on your server that many plug-ins require. If you do not control or operate your own server, you should let your service provider know the MIME-types that you need to have supported. Setting up servers for some of the multimedia plug-ins is not a trivial task, and many Internet service providers will not support high-bandwidth data streams for fear of overwhelming their Internet connection by serving your streaming voice or video to the world. Indeed, while a plug-in or a player may be free and readily available to anyone who wishes it, the software to actually build, compress, manipulate, and serve the special data (such as for compressed images, compressed audio, streaming video, animations, and VRML worlds) may be difficult and expensive, since the company makes money from the development tool, not the client software.

#### **14.1.1 Purpose**

Various applications support plug-ins for many reasons. Some of the main reasons are as follows:

- They enable third-party developers to create abilities which extend an application
- Plug-ins support easy addition of new features
- Plug-ins reduces the size of an application
- It separates source code from an application because of incompatible software licenses.



### 14.1.2 Features of Plug-in

Notes

1. It Works with any blog site.
2. Plug-in helps to Upload video productions.
3. It can create amazing slideshows.
4. Audio, slideshows and video can be heard and seen worldwide by the help of the plug in.

### 14.1.3 Most Useful Firefox Plug-ins for Web Developers

**Firebug:** Firebug integrates with Firefox to put a wealth of web development tools at the fingertips while browsing is done. You can edit, debug, and monitor CSS, HTML, and JavaScript live in any web page.

**Pixel Perfect:** Pixel Perfect is a Firefox/Firebug extension that allows web developers and designers to easily overlay a web composition over top of the developed HTML.

**Fire FTP:** Fire FTP is a free, secure, cross-platform FTP client for Mozilla Firefox which provides easy and intuitive access to FTP servers.

**Fire Shot:** Fire Shot is a Firefox extension that creates screenshots of web pages (entirely or just visible part). Unlike other extensions, this plug-in provides a set of editing and annotation tools, which let users quickly modify web captures and insert text annotations and graphical annotations. Such functionality will be especially useful for web designers, testers and content reviewers.

**Pencil:** Pencil is a free and open source tool for making diagrams and GUI prototyping that everyone can use. Some of the key features include: multi-page document with background page, on-screen text editing with rich-text supports, and PNG rasterizing.

**Window Resizer:** Window Resizer is useful tool for testing different screen sizes. It accurately resizes your browser so you can test to see if the web page you're working on looks right in all of the standard resolution sizes. It supports the 640×480, 800×600, 1024×768, 1280×1024, 1600×1200 resolution sizes.

**Codetch:** Codetch gives you the feel of Dreamweaver in a Firefox extension. It edits your documents right next to your web pages as you surf.

## 14.2 Text

In addition to variations in the size of the viewport, viewers of your website may not be displaying the same “preferred” font that you used to design your page because user preferences in the browser may alter the way text in your document looks and flows. To make the best of this uncertainty, many developers design their documents in Times Roman for the proportional serifed font, Verdana for proportional sans serif, and Courier as the mono spaced font. These fonts readily move across platforms and are the default fonts users typically see if they do not set their own preferences. Although you can specify a font, and even alternate fonts, using CSS, browsers can only use a specified font if that font is installed on the end user's computer.

Text and document plug-ins such as the popular **Adobe Acrobat Reader** get you past the display limitations of HTML and web browsers, where fonts are dependent on end users' preferences and page layout is primitive.

In file formats provided by Adobe Acrobat, for example, special fonts and graphic images are embedded as data into the file and travel with it, so what you see when you view that file is precisely what the document's maker intended.

### 14.2.1 Making Columns of Text

The most powerful feature of HTML may be found in the `<TABLE>` tag.

Study this tag and its attributes! To the right, you'll see how to organize your text into two columns, so it displays more like a newspaper or a magazine, using a table (see Figure 14.1).

Figure 14.1

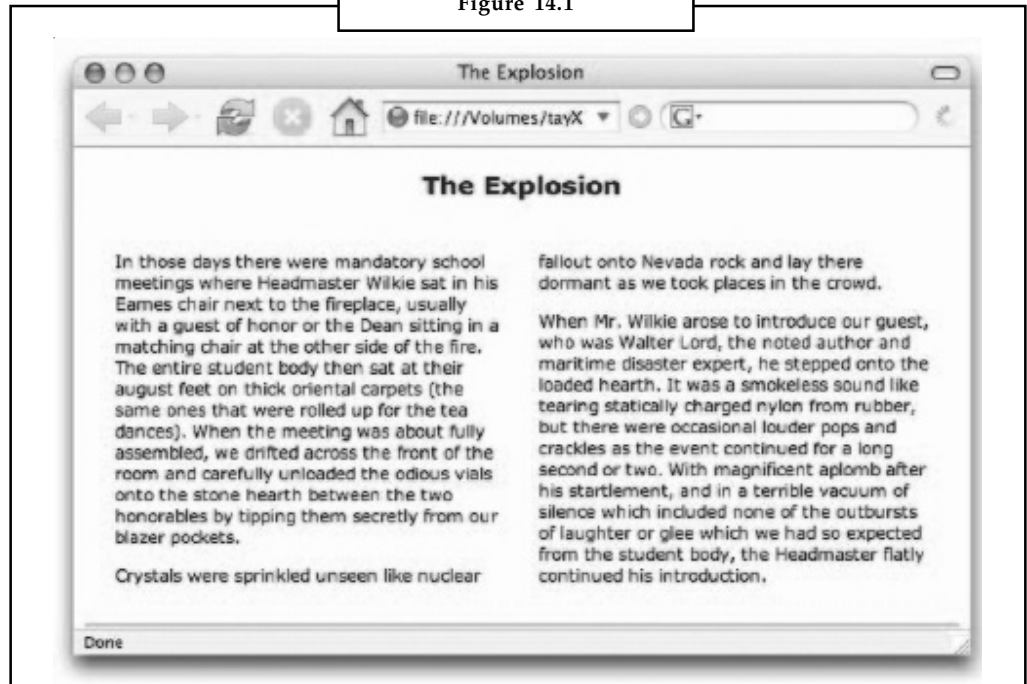

Using the `<TABLE>` tag, you can organize your text into columns.

```
<HTML>
<HEAD>
<TITLE>The Explosion</TITLE>
</HEAD>
<BODY>
<DIV ALIGN="center">
<H2>The Explosion</H2>
</DIV>
<TABLE BORDER="0" CELSPACING="20">
<TR VALIGN="TOP">
<TD WIDTH="40%">
... text for Column 1 goes here ...
</TD>
<TD WIDTH="40%">
... text for Column 2 goes here ...
</TD>
</TR>
</TABLE>
<HR>
</BODY>
</HTML>
```

## 14.2.2 Flowing Text Around Images

Notes

As you can see in Figure 14.2, it is possible (and easy) to “flow” text around an image using the **ALIGN attribute** of the <IMG> tag. This is a quick and simple method for mixing text and images in a pleasing layout. Add a <BR CLEAR=“left”> tag at the end of your text paragraph, so that if there is not enough text to fill the entire vertical height of the image, your next paragraph will begin on a new line, left-justified, and below the image. To add space around your image so it doesn’t butt right up against the text, use the Horizontal Space (**HSPACE**) and Vertical Space (**VSPACE**) attributes of the <IMG> tag.

Figure 14.2

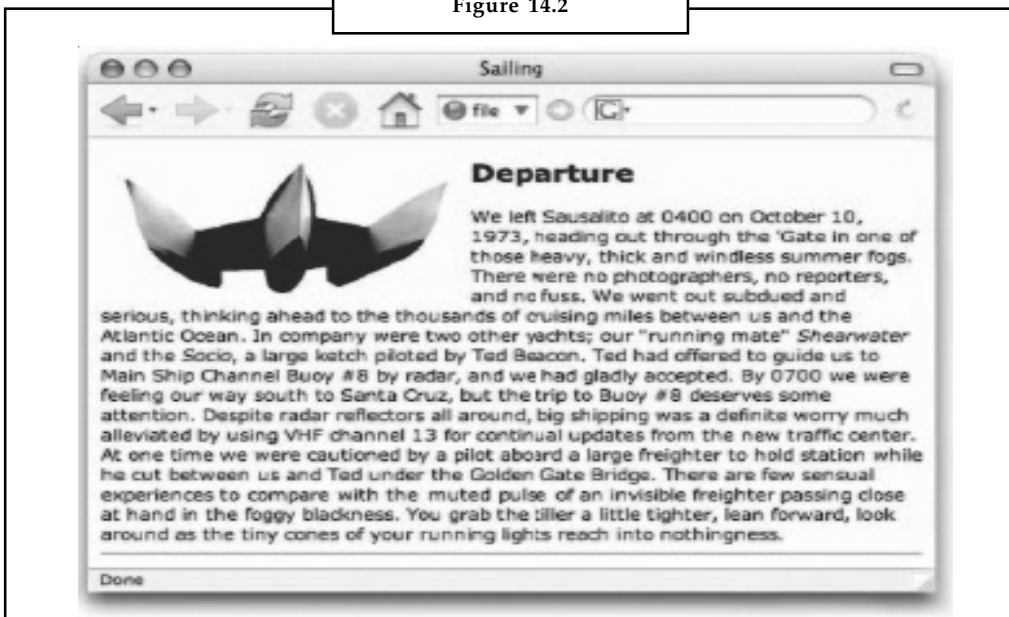

You can flow text around an image by using the ALIGN attribute of the

```
<IMG> tag.
<HTML>
<HEAD>
<TITLE>Sailing</TITLE>
</HEAD>
<BODY>
<IMG SRC="gbsky.gif" ALIGN="left" HSPACE="15" VSPACE="5">
<H2>Departure</H2>
... text goes here ...
<BR CLEAR="left">
<hr>
</BODY>
</HTML>
```



*Notes* As with projects built for CD-ROM or DVD distribution using a multimedia authoring tool, if you wish to absolutely control the look of text on your web page, you must use a graphic bitmap rather than text in your HTML document. Adding images in place of text, however, increases the amount of time necessary to download your page.

Notes

**Self Assessment**

Fill in the blanks:

1. A ..... is bits of computer code that is combined with a host application to perform specific functions.
2. .... integrates with Firefox to put a wealth of web development tools at the fingertips while browsing is done.
3. .... is a Firefox/Firebug extension that allows web developers and designers to easily overlay a web composition over top of the developed HTML.
4. .... edits your documents right next to your web pages as you surf.
5. It is possible (and easy) to “flow” text around an image using the ..... of the <IMG> tag.

**14.3 Image**

Theoretically, the Web can support any graphics format the client and server have in common. Practically, even though web standards do not specify a graphics format you must use, browsers recognize four image formats—GIF, PNG, JPEG, and SVG—without resorting to special plug-ins. These formats use built-in **compression algorithms** to reduce file size. (Graphic image formats are described in detail in Unit-4: Image). For other graphics formats, such as CGM, CMX, DXF, and fractal- and wavelet-compressed images, special proprietary creation software and browser plug-ins may be required.

**14.3.1 GIF and PNG Images**

GIF images are limited to 8 bits of color depth (256 colors). This is a commercial image format developed by CompuServe Information Services, an online company once owned by Unisys and currently folded into America Online. In late 1994, Unisys announced a patent fee charge to all software developers who use the GIF format. In an angry, industry-wide response, **PNG** (for Portable Network Graphics Specification) was developed as a new “open” format (not requiring fees) to replace GIF. By allowing transparency by single pixel or by alpha channel mask and a 24-bit indexed palette, the PNG format is an improvement on the GIF format it was intended to replace. But it does not support animation. And because it only uses the RGB color model (not CMYK), PNG images may not print well.

**14.3.2 JPEG Images**

JPEG (Joint Photographic Experts Group) images may contain 24 bits of color depth (millions of colors). JPEG uses a powerful but **lossy** compression method that produces files as much as ten times more compressed than GIF. Lossy means that information in the original image is lost in the compression process and cannot be retrieved. A **lossless** compression method does not irretrievably discard the original data.



*Caution* Do not edit and reedit files that are in JPEG format. Every time you open a JPEG image and edit it, then recompress and save it as a compressed JPEG, the image degrades. After a few editing/saving cycles, you will be very disappointed. Edit and archive your images in a 24-bit lossless graphic format (such as TIFF, BMP, or PSD), then convert to JPEG.

The JPEG compression scheme compresses about 20:1 before visible image degradation occurs. Test the amount of compression acceptable for your JPEG image; stay inside the “threshold of visible error.” To compress an image with JPEG, the image is divided into  $8 \times 8$ -pixel blocks, and the resulting 64 pixels (called a “search range”) are mathematically described relative to the characteristic of the pixel in the upper-left corner. The binary description of this relationship requires far less than 64 pixels, so more information can be squeezed into less space.



*Did u know?* JPEG compresses slowly, about one to three seconds for a 1MB image, depending upon computer speed, but JPEG can compress images as much as 75:1, with loss.

### GIF or JPEG?

Use JPEG for photo-realistic images containing many colors, and avoid using it for images already forced into a 256-color palette or for line drawings or 1-bit black-and-white images. GIF compresses drawings and cartoons that have only a few colors in them much better than JPEG, which may introduce visible defects—sharp edges and lines that blur—especially with small-size text. Figures 14.3 and 14.4 show the “blocky” and “lossy” nature of the compressed JPEG images. For the Web, use the JPEG format for photo-realistic images that are busy with color; use the GIF format for line art and drawings where there are large areas of the same color.

Figure 14.3: Blocky Nature of the compressed JPEG images

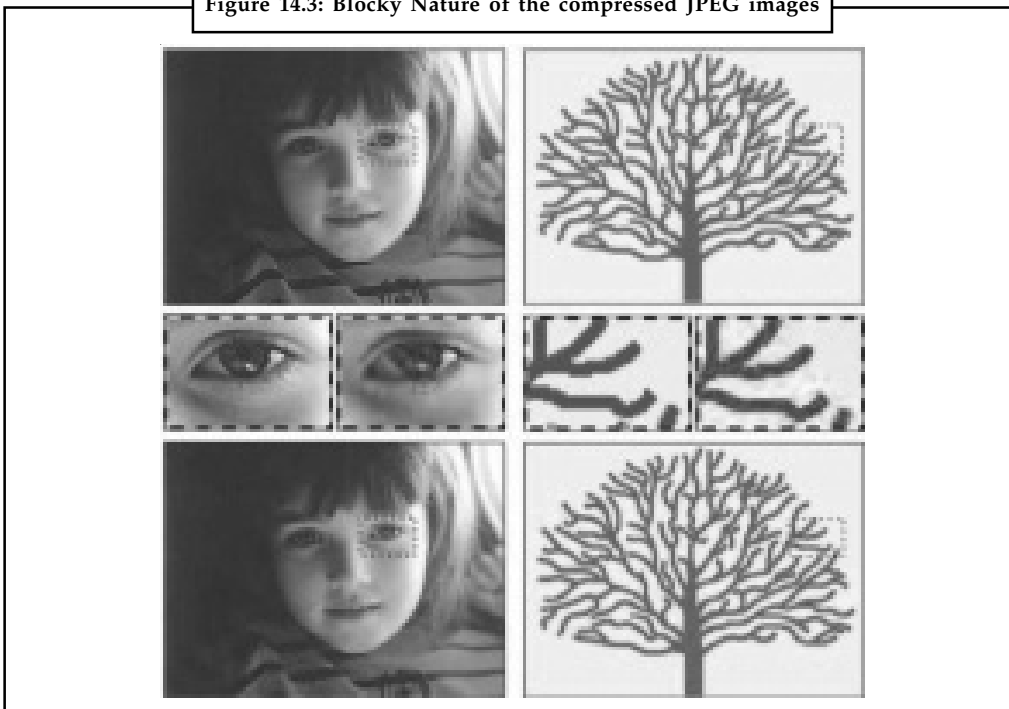

In Figure 14.3, both images at the top were saved in the JPEG format, which compresses image data and trades image quality for small file size. The resulting compressed images at the bottom show the “lossy” and “blocky” nature of compressed JPEGs. The photo at top left is 71K in size when saved as a GIF (not shown) and only 27K saved as a JPEG (bottom left). The drawing at top right is 17K when saved as a GIF (not shown) and 46K as a JPEG (bottom right).

## Notes

Figure 14.4: Lossy nature of the compressed JPEG images



Lossy compression schemes save disk space but can also degrade an image. For the Web, line art is often better saved in GIF, PNG, or SVG format than in JPEG.

### 14.3.3 Using Photoshop

Adobe's Photoshop is the "tool of choice" for most graphic artists, so it is worth taking some time to provide a few suggestions for creating images for use on the World Wide Web. If you use a different image-editing application, follow the same logic and use the commands appropriate for that application. Always work in native Photoshop format using PSD files—these images are typically in RGB mode and use the maximum color depth. They are larger, but they contain more information that can be usefully processed when resizing and dithering, and you will get better final results. PSD files also contain layers, a very useful application feature. When creating images for display on a web page, use 72 pixels per inch resolution, which is the resolution of most monitors. When you convert a 24-bit RGB image to an 8-bit indexed image (change its mode), you lose huge amounts of color information that cannot be retrieved, meaning that the fine data is gone forever. So you should follow two practices in order to protect your original image. One is to save the original image in a 24-bit lossless image format (such as PSD, TIFF, or BMP). The other is to do all of your image manipulation (such as resizing, sharpening, and hue adjustments) in RGB mode. Next, save this source image in RGB mode as a PSD file, before reducing the color palette by saving it as a GIF or using a lossy compression like JPEG. By saving the high-quality original and saving the manipulated image in the program's native format, you can return to them if you need to make changes later.

When you are satisfied with your image and ready to save it as a GIF, PNG, or JPEG file, archive it as described earlier. If you make any mistakes while converting modes or saving, you will still have the original, complete with any layers you might have used. To be very safe, duplicate the original file and open the copy before saving to other formats.

#### Saving as JPEG Files

To save your image as a JPEG file, you do not need to change Photoshop's mode from RGB, but if you are using layers, you will need to "flatten" the image, merging all layers into a single

bitmap. Once an image is flattened and you have edited or saved it, its layers cannot be remade without a great deal of difficult cutting and pasting—so again, archive your original file!

You must name your file with the extension .jpg or .jpeg if you will use it on the Web. Then click Save, and choose Maximum, High, Medium, or Low-quality compression in the dialog box that appears. Your file is ready for the Web.

### Saving as GIF Files

To save a GIF file using Photoshop, you must first set the mode of your image to Indexed Color, converting it to the best 8-bit palette (256 colors) that will represent the image and be displayed well by web browsers. Note that the option of saving a Photoshop 24-bit RGB file in GIF format will not be available in Windows, and it will be grayed out on the Macintosh menu until you have converted your image to 8-bit mode: GIF is only for 8-bit images.



*Notes* Use GIF files for line art and images that contain large areas of the same color (that can be easily compressed). Use JPEG for photo-realistic images.

### 14.3.4 Palettes

A palette is both the board on which an artist puts selected colors and also the set of colors themselves. On the Web, choosing the colors you use not only involves understanding which colors work well together but also understanding the capabilities of display screens and browser for displaying the colors you choose.

When you change the mode to Indexed Color, you must specify the color depth of the converted image, the color palette to be used, and whether the colors of your image should be dithered (Diffusion or Pattern) or not (None). Figure 14.5 shows the mode changing dialog box from Photoshop, where the custom Netscape Navigator palette for Windows has been selected.

Figure 14.5: The mode changing dialog box from Photoshop

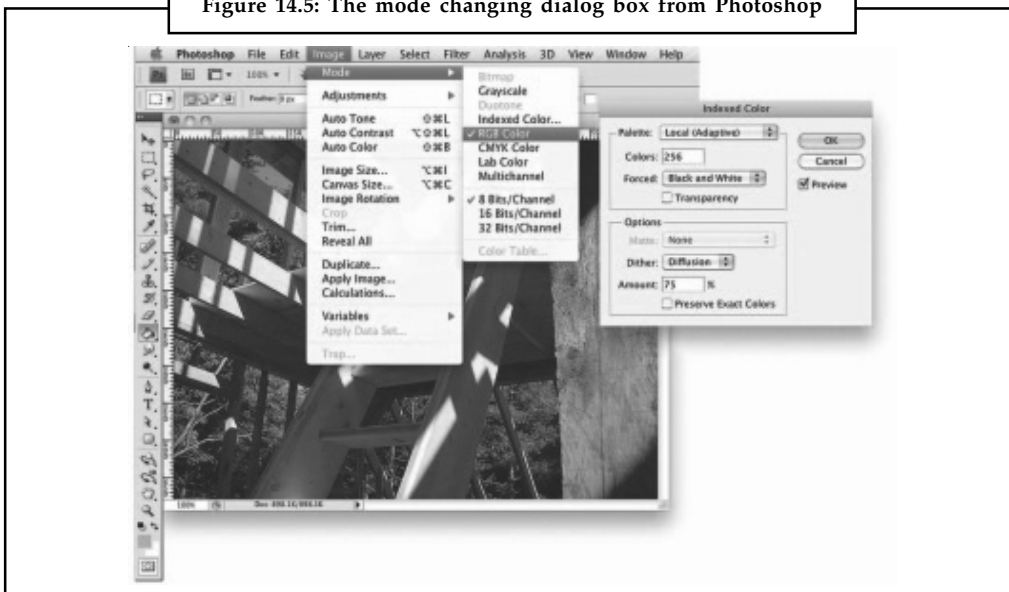

In the figure 14.5 it is shown that in Photoshop, changing the mode of your image from RGB Color to Indexed Color changes the color depth of your image.

### 14.3.5 Interlaced and Progressive Scans

Both GIF and JPEG images can be saved so that when your browser displays the image as it is being downloaded, you can immediately see a chunky approximation of the final image, with resolution improving as more and more data comes in. While in baseline, or normal configuration, image data is stored as a single top to bottom scan; in **interlaced** GIF and **progressive** JPEG files, the data is organized in a different sequence within the file. An interlaced GIF file, for example, is arranged into a series of four passes:

*Pass 1:* Every 8th row, starting with row 0

*Pass 2:* Every 8th row, starting with row 4

*Pass 3:* Every 4th row, starting with row 2

*Pass 4:* Every 2nd row, starting with row 1

Figure 14.6 shows Photoshop's Save for Web & Devices dialog for saving an image as interlaced, and four increasingly resolved images. With interlacing, the image incrementally improves its resolution as it downloads.

Figure 14.6: Interlacing settings when exporting a GIF89a file from Photoshop

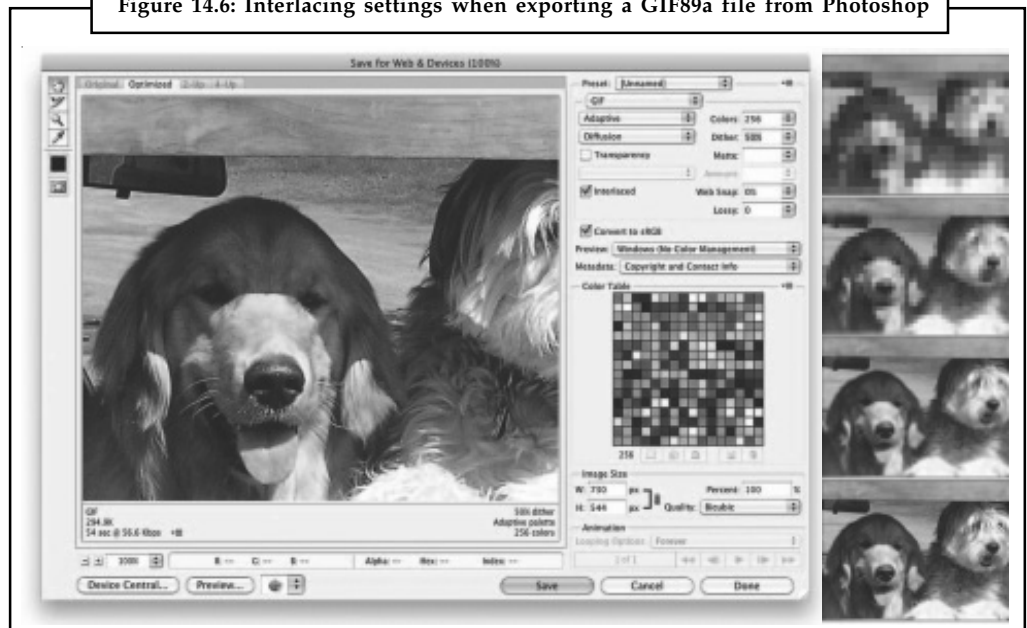

### 14.3.6 Transparency

The GIF89a and PNG specifications allow for **transparency**: you can save your file with instructions to a browser to use a specific color or palette of colors (with PNG) as your selected transparency color. In many cases, such as for company logos and in-line illustrations, it is attractive to let an image float on top of the browser's background. Images on web pages are displayed as rectangles. The area outside of the circle in Figure 14.7 is filled with a wash of color and would (without transparency) be displayed as a rectangle showing those colors to its edges. To make the part surrounding the circle transparent so that the circle floats on your web page, fill the area outside the circle with a single color, and then save the file, selecting that fill color to be transparent. While white is often used as the transparency color, in this example it would not work because there are white pixels inside of the circle that would also become transparent. Use a fill color not



in the area you wish to show; in this case red works. Most image-editing tools provide a palette from which you can select the transparency index color. You cannot make a JPEG file transparent.

Given below Figure 14.7 shows the use a transparent GIF or PNG to float a circle or other image on webpage: select the area outside of the circle (upper left), fill it with a single indexed color (red, lower left), choose that color to be transparent (lower right), and save the image as a GIF file. The circle will float on your page (upper right).

Figure 14.7: Transparency

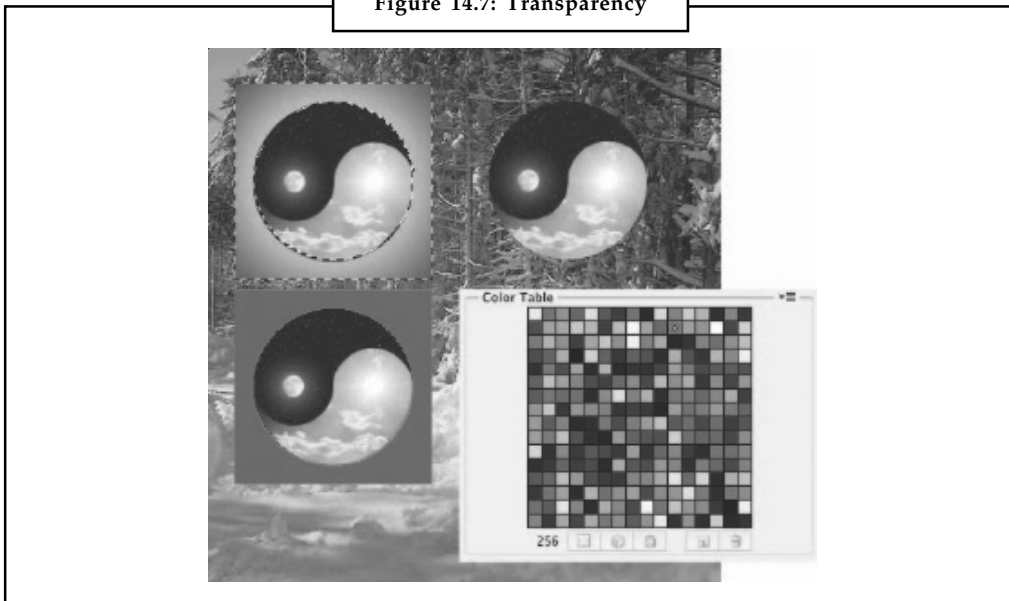

## 14.4 Sound for the Web

In the beginning, when the Internet was primarily a collection of Unix machines, sound files were sent from machine to machine in **AU format** and, when downloaded, were played back using a sound application. As the Web has developed, sound has become more important, and most browsers allow embedding of sounds into documents using the `<AUDIO>` tag. Inside this tag, the **autoplay** attribute, if present, starts the audio playing as soon as it is ready. If **controls** is present, a play/pause and other controls will be displayed. When **preload** is present, the audio will load when the page does and be ready to run. Text can be included in the tag that will be ignored unless the user's browser cannot understand the `<AUDIO>` tag:

```
<audio src="LizLaugh.aiff" preload autoplay controls loop> Sorry, your browser does not support the HTML audio element. </audio>
```

The `<A>` anchor tag and `<EMBED>` tag can also be used to play sound files:

Click `<a href="LizLaugh.aiff">here</a>` to play sound file.

```
<embed src="Mozart.mid" autostart="true" loop="false" width="120" height="50" hidden></embed>
```



*Caution* For Making sound for the Web it is recommended to always nibble at the sound elements and reduce them to the lowest file sizes that will play acceptably. Remember, they will move across the Internet and may be downloaded or played on machines with low-bandwidth connections.

## **14.5 Animation**

HTML makes no provision for animation, by itself delivering only a static page of text and graphics. Boring, many people said, and programmers went to work devising methods to liven up the view. JavaScript can dynamically change a web page without needing to reload it. JavaScript with XML features, combined into **Ajax** (Asynchronous JavaScript and XML), is used for powerful interactive applications such as Google's "Office." The Flash plug-in for browsers offers animation and interaction.

### **14.5.1 Animation with JavaScript**

JavaScript makes webpage content dynamic, allowing user interaction and animation. The principle of JavaScript animation is rather simple; webpage elements, most often images, have their style or position within the page altered by a script. Repeating this process at sufficiently short intervals has the effect of simulating smooth motion of the element about the page.

### **14.5.2 User Control over GIF89a**

Browsers implement a little-known animation feature in the final 1989 revision "a" of the GIF file format specification. It is possible to make simple animations by putting multiple images, or frames, into a single GIF89a file and display them with programmable delays (in 100ths of a second) between them. When you use the <IMG> tag to embed a GIF89a **multiframe image**, the browser downloads the file and stores it in the cache folder of your local hard disk. Once fully downloaded, the browser plays each frame of the image quickly and smoothly. Limit animated GIFs to small images, and use a more capable plug-in like Flash for animations over larger areas.

The animation option of the GIF format combines individual GIF images into a single file to create animation. You can set the animation to loop on the page or to play once, and you can designate the duration for each frame in the animation. Animation software includes Swish ([www.swishzone.com](http://www.swishzone.com)), Flash, Director, After Effects, DHTML, and animated GIF files built using shareware and freeware. Designers must be careful how they use animation though: too much motion and too many flashy colors can cheapen a website. Subtle animation, however, enhances a site's content and messages.

### **14.5.3 Uses of Animation on Web**

There are things to consider before deciding to use animation on a Web page. It is necessary to know if it adds value to the page or detracts from using the page. There are also certain rules to keep in mind when adding animation to a Web page. Animations are usually done in Adobe Flash, although Java and GIF animations are also used in many websites.

*Reasons and Detractions of Animation:* There are various reasons to have motion on a Webpage. They include:

- Draw attention
- Demonstrate something
- Entertain
- Assist in navigation

There are also downsides to misuse of animations in these cases. Details are explained below:

**Drawing Attention:** You can use animation to draw attention to something you want the user to look at. This can be blinking of the text to movement of the items.



*Example:*

- You all have seen banner advertisement in Web sites. The animations in the advertisement are intended to attract your attention and entice you to take an action, like clicking on the banner to see more about the product or service.
- Another example is an animated company logo. Its movement draws your attention to the logo.

**Demonstrating Something:** One reason to have animation is to help to demonstrate something you are explaining in your message. Although a picture or illustration is useful, in some situations, it is not sufficient to describe some action. An animation or video is necessary.

An example of this is demonstrating how a device works.

This type of animation is also useful in showing science principles.

An example of a Java-based animation used to demonstrate a science principle can be seen in Demonstration of Space Satellite in Orbit.

You often see animation in slideshow presentations, such as those done with Microsoft PowerPoint, where titles or text moves across the screen into few. This type of animation can be effective for the first few slides but soon becomes boring. TV commercials use animated text sparingly, and it can also be used on web sites. Some effectively stream text to get across a message.



*Notes* Animations or videos that take too long to download or that require another plug-in often result in abandonment of the page.

**Entertaining:** Entertainment in the form of a game or a comic strip often uses motion fulfill its goal or to keep interest. There are many online game and entertainment sites on the Web. Entertainment when it isn't asked for is a turn-off. This type of animation is also not appropriate for most business sites.

**Assisting in Navigation:** Animation can be used to assist the user in the navigation of a Web site. One common example is the mouse-over effect, that lets you know the button or graphic leads to another page. This is especially useful, if there are other similar graphics that are not active.

What is more useful in aiding navigation is when a mouse-over gives some textual information about what is on the linked page? Blinking buttons that scream "click me" are slightly useful and can become irritating if they interfere in using the page.

Navigation aids that are too clever to be understood are useless.

**Put Life in Page:** Animation can put some life into a flat web page. On the other hand, too much animation can be irritating and unnecessarily slow the delivery of the page.

**Can Show Creativity:** Sites advertising creative services especially related to graphical design, entertainment, or advertising should have animation to show off their creativity.

**Animations Different than Interactions:** You have to differentiate between animations and interactions. A mouse-over that displays some text is more of an interaction. A flashing arrow that says "click-me" is pointing the user in a certain direction.

Notes

  
*Task* Pick a tool or method and create an iphone commercial with slogan.

**Self Assessment**

State whether the following statements are true or false:

6. The GIF is a lossy compression in which data is lost.
7. To save a JPEG file using Photoshop, you must first set the mode of your image to Indexed Color.
8. To save your image as a JPEG file, you do not need to change Photoshop’s mode from indexed color.
9. Lossy compression schemes save disk space but can also degrade an image.
10. A lossless compression method irretrievably discards the original data.
11. Portable Network Graphics Specification was developed as a new “open” format to replace GIF.
12. The animation option of the GIF format combines individual GIF images into a single file to create.

  
*Case Study*

### Web Design Success Story

Composition in Web design is similar to good composition in print design. It is a process organizing and communicating in a way that is both functional and aesthetically pleasing. Web design is often even more complex because of the processes of navigation and multitude of variables in user interaction. Order and unity become vital communication ideals.

**SamataMason.com Notes**



**SamataMason Website**

Many of the attributes of good Web design can be found on the Website of the well-known Chicago design firm, Samata Mason. The introductory screen is simple and well organized. The elements of text blocks and image float on a gray background and can be readily brought up on either a small or large monitor without having to scroll left/right or top/bottom.

*Contd....*

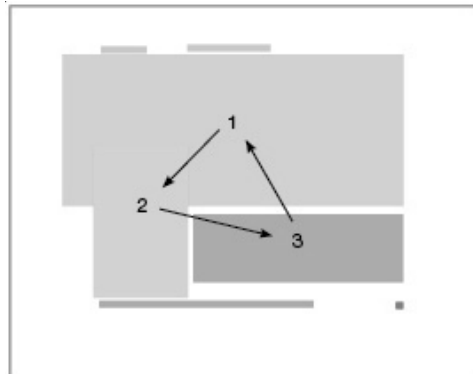
**Hierarchy****Hierarchy and Composition**

The site has essentially a four tiered hierarchy that is emphasized by size and direction. The image, a horizontal rectangle, is the most important element and the top level of importance is emphasized by the large scale. The second level, a vertical rectangle, is a list of category choices. The third level, a horizontal rectangle, is a brief paragraph of descriptive information. Subordinate information including the heads, company name, and rating control complete the page.

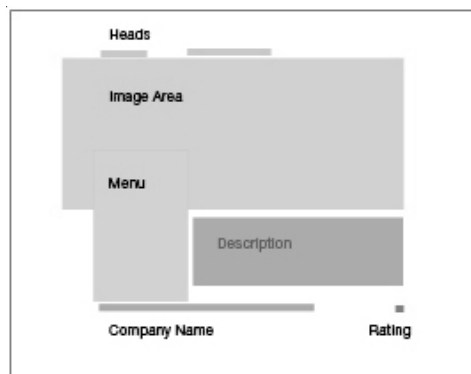
**Composition****View Analysis Diagram**

The scale of the major visual elements of image and text blocks are pleasing. The text blocks of the heads, menu, and company name align and give a sense of order. The menu block overlaps the image on a transparent field that literally overlaps and attaches itself to the image and provides unity. The eye moves fluidly from the image to the menu to the description that is tucked in the negative space. This triangular movement feels comfortable, keeps the user focused on the center of the page, and enhances the cohesive feel of the page.

**Brevity**

The simplicity of design makes the web site inviting from the start. Although there is a lot of information the user is met with an engaging organizational structure. Choices are clear and to the point, and the minimal descriptive text is well written. Long blocks of text sometimes turn-off the viewer because of the length, and are often ignored. Short blocks are much more enticing and in the case of Samata Mason delightful to read.

*Contd....***Notes**

Notes

**Cropped Images**

It is interesting that in all cases the images are not typical studio shots of a complete printed spread or an object but rather a tightly cropped detail of a larger image. The result is an intriguing composition that incites curiosity. Because of resolution constraints it is often difficult to show an entire image effectively. This system allows the viewer to appreciate the details of the design and get the gist of the project.

**Visual Analysis**



**Submenu Choices, (right)**

The visual analysis diagram breaks the elements on the web page down into simple defined areas. The largest visual element is the image area, shown in light red, as a horizontal rectangle. This image area is systemized on each web page and becomes a standard visual element for each page. Even though the image changes on each page the size and placement of the does not. This yields a sense of continuity and rhythm to the site even as the information changes.

Text information occupies four positions on the web page. The top two blocks are short headlines. The long vertical text block is a menu with a series of choices that link to other text pages. The large horizontal text block is a short descriptive paragraph of informative copy. The company name occupies the bottom text block and aligns with a plus sign in brackets that when clicked invites the viewer to “rate the page.”

**Rating & Feedback**



**Rating & Feedback, (lower right)**

Contd....

## Notes

The page rating invitation gives the viewer an opportunity to provide direct feedback to Samata Mason about the effectiveness of their web presence. The viewer can quickly rate the page and if desired can click the “comments” category, which opens another window, to provide written feedback and rate the page as to content, design, usability, and overall. Clearly, the firm cares about the web usability of the site and is interested in the opinion of the user.

Subsequent web pages become only slightly more complex with the addition of another block of text to the right of the description. This block lists a series choices within the category and serves to show the firm’s range of capabilities. The viewer is readily engaged in the information because the choices are so clear that he/she knows immediately how to access information. There is no time lost figuring out how to navigate or return to a previous selection.

### Grid System

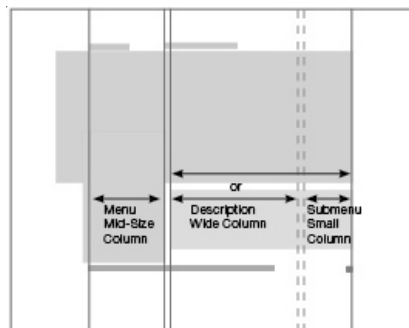

Grid Alignment

Just as the image and text block proportions change from large to medium to small, so too does the grid. The system is a three column arrangement in three widths. The largest width is reserved for paragraphs of descriptive copy. The medium width contains the main menu choices, and the narrowest width is used when needed for additional submenu selections. If no submenu is used the description column occupies the entire width of the two right side columns.

The intent of the site is to inform the viewer of the capabilities and philosophy of the firm. It does so admirably and in the process persuades the user that Samata Mason is experienced, organized, capable, and highly caring. How can you use these principals in your designs to create the same impact? Thoughtful design takes time and thought, but as you can see Samata Mason spent both well and created something we can all learn from.

### Questions:

1. Demonstrate the tools or techniques of developing a Web page.
2. What are the attributes of good Web design?

Source: [http://www.wpdfd.com/issues/83/web\\_design\\_success\\_story/](http://www.wpdfd.com/issues/83/web_design_success_story/)

## 14.6 Summary

- The World Wide Web was designed as a simple method for delivering text and graphics. The Manipulation of the appearance of text on the Web can be done by:
  - ❖ choosing the fonts carefully: Viewers may not have that special fonts installed on their computers.

Notes

- ❖ Using HTML tables to create columns of text.
- Flow text around images using the ALIGN attribute.
- Image formats, GIF, PNG, and JPEG, use built-in compression algorithms to reduce file size.
- GIF images are limited to 8 bits of color depth, or a palette of 256 colors while JPEG and PNG images may contain 24 bits of color depth.
- GIF files for line art and images that contain large areas of the same color. Use JPEG for photorealistic images.
- The GIF89a specification allows for a selected transparency color. You cannot make a JPEG file transparent.
- JPEG and PNG use a powerful but lossy compression method that produces files as much as ten times more compressed than GIF.
- Most browsers allow you to specify an image or color to place in the background of your page in the <BODY> tag. Text and images will float on top of this layer.
- CSS is used to control the color of text in a document.
- Background images are automatically tiled, or repeated, across and down the page unless told not to using CSS.
- Placing an image inside an HTML anchor tag makes the graphic image clickable.
- Image maps are pictures with defined hot spots that link to other documents when a user clicks on them.
- Including animation on the webpage is usually done in Adobe Flash, although Java and GIF animations are also used in many websites.

### 14.7 Keywords

**Compression:** Compression is the reduction in size of data in order to save space or transmission time.

**Fire FTP:** Fire FTP is a free, secure, cross-platform FTP client for Mozilla Firefox which provides easy and intuitive access to FTP servers.

**Fire Shot:** Fire Shot is a Firefox extension that creates screenshots of web pages (entirely or just visible part).

**JPEG:** JPEG is a term for any graphic image file produced by using a JPEG standard. A JPEG file is created by choosing from a range of compression qualities.

**Nibble:** In computers and digital technology, a nibble is four binary digits or half of an eight-bit byte.

**Palettes:** In computer graphics, a palette is the set of available colors. For a given application, the palette may be only a subset of all the colors that can be physically displayed.

**Plug-in:** A plug in is bits of computer code that, combined with a host application, perform specific functions.



## 14.8 Review Questions

Notes

1. Describe the Plug-ins and its characteristics.
2. Illustrate the most useful Firefox Plug-ins for Web Developers.
3. What are the ways to manipulate the appearance of text on the Web?
4. Determine which graphics formats are best suited for different types of images.
5. Give a note on 'Sounds for the web'.
6. Define JPEG image.
7. How to save the image file using GIF format?
8. Describe uses of animation on a webpage.

### Answers: Self Assessment

- |                    |             |
|--------------------|-------------|
| 1. plug in         | 2. Firebug  |
| 3. Pixel Perfect   | 4. Codetech |
| 5. ALIGN attribute | 6. False    |
| 7. False           | 8. False    |
| 9. True            | 10. False   |
| 11. True           | 12. True    |

## 14.9 Further Readings



Books

Frederick P. Brooks, Jr., Kenan Professor of Computer Science, *The Mythical Man-Month: Essays in Software Engineering*, University of North Carolina at Chapel Hill.

K. Andleigh and K. Thakkar, *Multimedia System Design*, PHI, PTR.

Steve Rimmer (2000), *Advanced Multimedia Programming*, MHI.

Tay Vaughan, *Multimedia Making it work*, Seventh Edition, Tata McGraw-Hill Education Private Ltd.



Online links

<http://my.safaribooksonline.com/book/animation-and-3d/9780133052718/12dot-intermediate-animation-tasks/ch12#X21udGVybmfSx0h0bWxWaWV3P3htbG1kPTk3ODAxMzMwNTI3MTglMkZjaDEybGV2MXNlYzUmcXVlcnk9>

<http://nora.lis.uiuc.edu:3030/companion/view?docId=blackwell/9781405103213/9781405103213.xml&doc.view=print&chunk.id=ss1-2-10&toc.depth=1&toc.id=0>

[http://users.mct.open.ac.uk/yr258/papers/Rogers\\_Scaife98.pdf](http://users.mct.open.ac.uk/yr258/papers/Rogers_Scaife98.pdf)

<http://www.icheg.org/icheg-game-history/timeline/>

**Notes**

<http://www.ict.griffith.edu.au/teaching/1611ICT/mm1alectures/l11/Writing%20For%20Multimedia%20Great%20Moments%20In%20Multimedia%20History.htm>

<http://www.phon.ucl.ac.uk/home/mark/audio/play.htm>

<http://www.webdesignfromscratch.com/web-design/effective-text/>

**LOVELY PROFESSIONAL UNIVERSITY**

Jalandhar-Delhi G.T. Road (NH-1)

Phagwara, Punjab (India)-144411

For Enquiry: +91-1824-300360

Fax.: +91-1824-506111

Email: [odl@lpu.co.in](mailto:odl@lpu.co.in)